



Hassay Savage Company

Precision · Performance · Profitability



OUR HISTORY

Founded in 1969, Hassay Savage Company begins its fourth decade as a family-owned manufacturer of precision broaches. In our first forty years, we have established our reputation at the forefront of broaching systems as a producer of quality standard broaches and bushings while increasingly proving our capabilities in the area of customized broaching. We intend to maintain both the standard and special broaching needs of our growing customer base.

Since 2005, the resurgent tool-making industry faces an exciting challenge to provide cost-effective solutions for our complex industrial society. Hassay Savage's achievements rest on the shoulders of the company's skilled tool and die makers. We are committed to supporting our fine craftsmen with the necessary state-of-the-art resources: in design (AUTO-CAD), in computerized and process manufacturing (CNC and CAM), and through process control and process analysis (SPC). In doing so, we stand ready to address your broaching applications, questions and problems—and to make solutions for you.

Hassay Savage Company is in the business of making quality standard and special broaches because we believe broaching can provide our customers with greater profit. Our full line of services include:

- cost analysis of broaching versus other machining processes;
- complete design assistance;
- warranty-backed product;
- quick delivery.

If the broaching process proves to be the more cost-effective approach for your manufacturing process, a Hassay Savage precision broach is the solution. Our standard or special broaches are ground by our technically advanced manufacturing systems to meet the most exacting specifications. A Hassay Savage high-speed steel broach has longer life, gives cleaner cuts, and requires less frequent sharpening and replacement.



Talk to one of our engineers today about your broaching needs. At Hassay Savage we listen to your concerns; we will work with you to meet your product goals while increasing your profit margin. Your business is our business.

Our catalogue provides you with the information you need either as you consider for the first time the broaching alternative to reaming, milling or shaping; or as you consider turning to Hassay Savage for tooling or retooling your broaches.

Hassay Savage presents a comprehensive line of high-speed steel broaching tools capable of critically accurate cuts in many configurations while producing extraordinary smooth surface finishes.

We can show you how broaching can be a superior, cost-effective alternative to other machining processes customarily employed to mass-produce identical parts.

Hassay Savage delivers topnotch, well-engineered, and profitable broaching tools, off-the-shelf or custom-designed. Our turnaround times are among the best in the industry.

Hassay Savage Company

10 Industrial Boulevard
Turners Falls, MA 01376-2251
TEL: (413) 863-9371 • FAX: (413) 863-2714
TOLL FREE: 1-800-247-2024
email: info@hassay-savage.com
<http://www.hassay-savage.com>



Contents

Types of Broaches	2-3
One Pass Keyway Broaches Overview	4
American Standard Keyway Broach sets	5
Metric Keyway Broach sets	6
Combination Sets	7
Heavy Duty Keyway Sets	8
American Standard Keyway Broaches, Bushings and Shims	9
Metric Keyway Broaches, Bushings and Shims	10
Standard Inch, Full, Metric Square Broaches	11
Rotary Broaches, Holders & Plugs	12
Internal Hex Rotary/Punch Broaches	13
Adjustable Rotary Broach Holders	14
Use Recommendations	15
Rotary Broaching Set-Up Plugs	16
Adjustable Rotary Broaching	17
How to Set Up Adjustable Rotary Broach Holder for CNC Machining	18
Rotary and Index Broaching	19
Non-Adjustable Rotary Broach Holders	20
CNC-Indexable Single Point Keyway Broaches	21
Standard Inch Square Push Broach	22
Hexagonal Push Broach	23
Davis Style Keyseating Broaches	24
500 & 600 Series Pull Type Broaches	25
Broaching	26
Broach Manufacturing	27
Broach Grinding Process	28
Cost Benefits	29
Rebuilding and Sharpening	30
Tool Materials Data	31
Using and Troubleshooting Broaches	32
Broach Lubrication	33
Special Broaches at Hassay Savage	34-35
Ordering	36
Broaching Machinery Available Through Hassay Savage	36
Note to our Distributors	36
Custom Broaching Request Form Inside Back Cover	37

Warranty

Hassay Savage Tools are warranted free from defects in material and workmanship in all cases of normal use. If under conditions of normal use a tool fails, it shall be repaired or replaced, at our option, when shipped prepaid to our factory in Turners Falls, Massachusetts 01376.

This warranty is made in lieu of all other warranties expressed or implied. This warranty does not cover tools which have been stamped for identification, experimented upon, or

otherwise modified, or tools which after examination prove to have been abused, or are without flaws in material or workmanship. Government regulations require use of safety glasses and other appropriate safety equipment in the vicinity of use.

Hassay Savage Company, Inc., authorizes no other warranty by any other person or agent, nor recognizes as binding any warranty made by such person or agent on our company's behalf. We assume no further liability, except as stated herein.

Credits: Jane Gottlieb for cibachrome hand-painting of photographs on front and back covers; Hyam Siegal, Edward Justice for photography except where noted.

www.magaforusa.com is also a division of Hassay-Savage Company



Types of Broaches

Broaching is a precision metal-cutting process which incorporates a series of rough, semi-finished, and finished teeth designed to remove successive portions of stock as the tool moves through or across a workpiece in a one-pass linear operation. Each tooth is calibrated to remove only a small amount of stock appropriate to the type of material broached, which permits continuous clean chip removal.

Surface Broaches

Surface broaching is the most commonly used in place of milling or shaping operations on surfaces of material parts or components. Surfaces may be flat, concave, convex, serrated, or cam-shaped. The tool is a simple flat bar with multiple rows of cutting teeth, usually attached by bolting or clamping onto a broach holder. Surface broaches can also be manufactured as insert sections and configured in a broach holder. Thereby lowering the costs of initial manufacturing and replacement.

Surface broaching is especially effective when compared to other machining methods because it produces highly finished surfaces of complex shapes with exacting dimensions and tolerances at a rate **many times** faster than the milling or machining processes.

Standard Broaches

The strength of our business at Hassay Savage has been built upon standard broaches available from stock and shipped on the same day the order is placed (see pages 5 through 25). We are one of a very few broach manufacturers who sell standard tools from stock, which means we can satisfy our customer's needs immediately.

Our sophisticated system of market distribution (400 industrial distributors and four factory warehouse locations) permits product to be in the customer's plant when most needed.

Broaching processes and tools are classified first as surface or internal; then as standard or special. Each broaching tool is designed to fit the starting print; its length and number of teeth are set by the kind of stock (e.g., machined, cast, or forged) and amount of metal to be removed.



Surface broach (used as set of 2) to broach two flats on CAM-actuated valve.

Special rectangular push broach for highly sensitive fluid metering device

Standard push keyway broach and guide system bushing; for 1/4" keyway in idler mechanism.

Internal Broaches

Starting with a round drilled hole, internal broaching can mass produce practically any internal hole configuration from the simplest application, reaming-to the most complicated, the rifling of gun barrels. Almost all internal broaching is done by pull broaches because they significantly remove more stock than push broaches, even where the workpiece has a thin or irregular wall. Also, a pulled internal broach can handle longer lengths of cut.

Internal broaching tools include the following: round pull, round push, rotor cut style, straight spline and serration, involute spline and serration, combination round and spline. They are faster and more economical than any other machining process: from round, and all derivative shapes of round, to internal gear spline, helical splines, and other irregular shapes.

Internal broaching solves scores of manufacturing applications that simply cannot be done any other way. For instance, there is no other way to make a precise square hole.

Surface applications include flats, notches, serrations, slots, intricate contours, turbine forms, key lock slots, connecting rods, external gearing.

Internal applications include tooling fixtures, gear and pulley keyways, keyways, rifling, hole configurations in all geometric shapes.

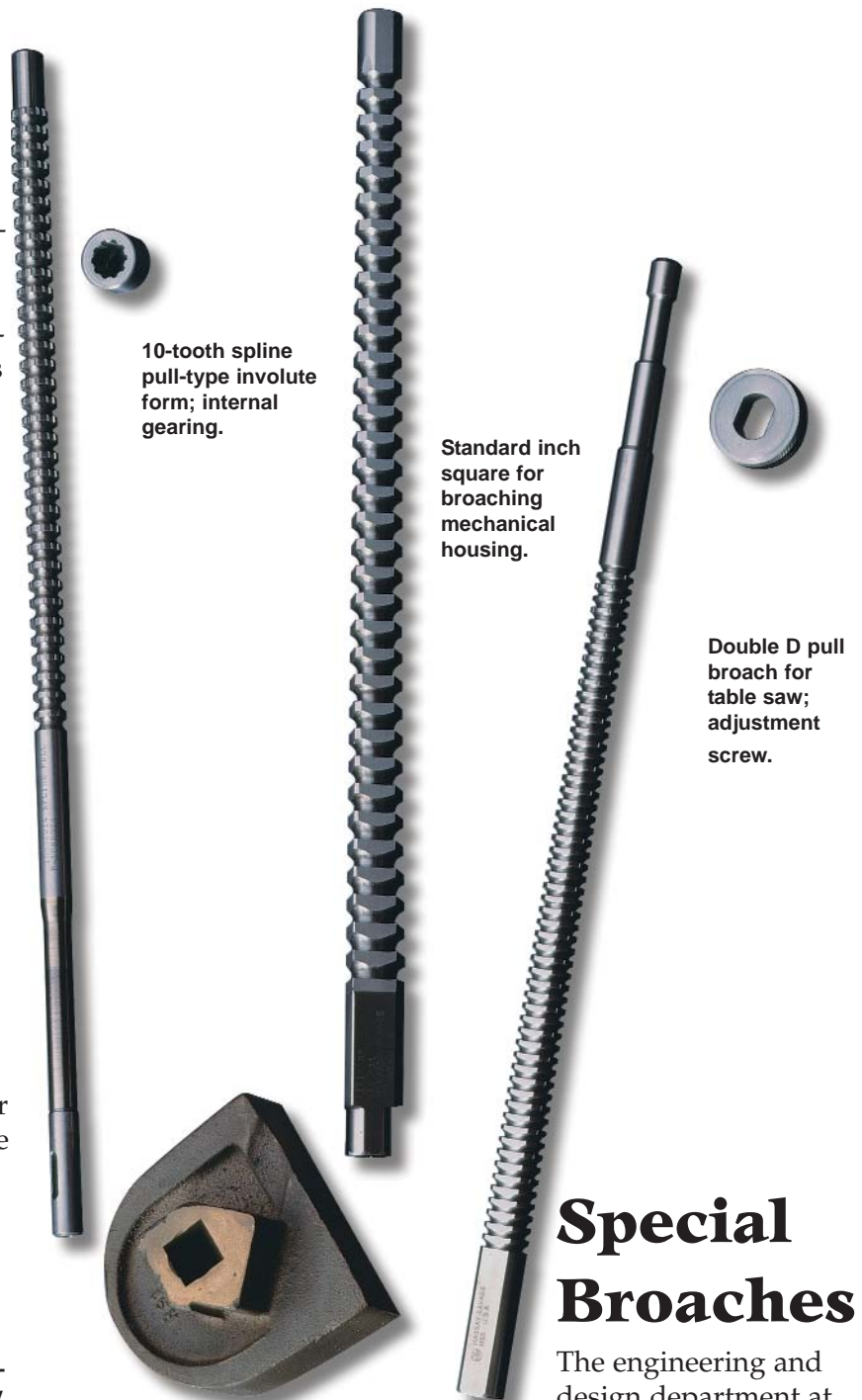

10-tooth spline pull-type involute form; internal gearing.

Standard inch square for broaching mechanical housing.

Double D pull broach for table saw; adjustment screw.

Special Broaches

The engineering and design department at our company offers a complete line of services for production of special broaches. As shown on pages 34 and 35, we are expanding considerably in this sector of the broaching market.

Our engineers can integrate the design and manufacturing process of your custom broach.

Keyway Broaches - American Standard



Hassay Savage HSS keyway broaches are available as standard items in sizes 1/16" to 1."

Rake and relief angles are precisely made for efficient broaching of mild steel.

Pressures listed in chart on facing page are for maximum length of cut. If these lengths must be exceeded, a special Hassay Savage keyway broach should be ordered for specific length of cut. In the event of thin pieces, pieces may be broached by stacking and nesting.

For special widths and depths, custom keyway broaches are also available within a 1 - 2 week period. This is an excellent delivery for the buyer looking for a special application in production or prototype.

Standard broaches may be ordered through your nearest Hassay Savage industrial distributor for off-the-shelf-delivery. When ordering from our standard stock, specify the EDP number with type and size as listed in the appropriate table

All of Hassay Savage tools are available with titanium nitride coating as a standard product.



Keyway broaches and bushings are clearly marked as to size, and any I Broach can be used with any I Bushing, and II Broach with II Bushing, etc.

Hassay Savage VI bushings are available on special order in dia. sizes 3 1/4" to 4 1/2." Required shims are supplied for each keyway broach. When order-

ing additional or replacement shims, specify EDP Number.

Shims correspond to broach size, not to bushing size.

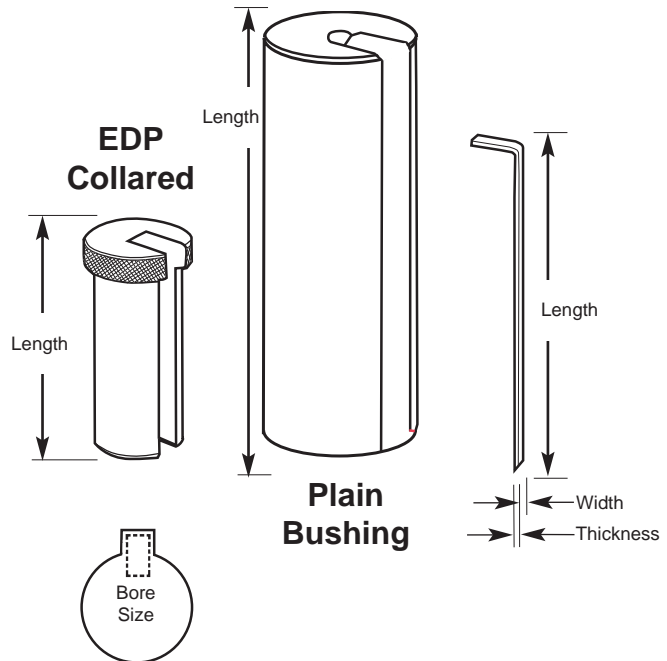

Keyway Broach Sets- American Standard

Keyway Range; 1/16 - 3/8"



Keyway Range; 1/16 - 3/8"
in Dura Case

Hassay Savage HSS broach sets come in durable plastic boxes and include broaches, bushings, shims and instructions.

These specification charts describe the dimensional cuts, configurations, tolerances, cut lengths, and machine tonnage for each standard broach we manufacture.

Selecting a standard broach from Hassay Savage is a simple process. Choose a tool, or set of tools that will produce the cut your finished part requires. Specify the EDP, size, and brief description when ordering to ensure proper delivery.

All standard products are maintained in finish good inventory. Often we can ship your order the same day it is placed. Additional special widths and lengths are also available from semi-finished stock ground to your specifications with quick delivery.

All tools listed are also available with titanium nitride coating as a standard product. Contact our customer service for details

Precision Set 1 Collared EDP No. 15315
3 Broaches and 5 Collared Bushings
15 Keyway Combinations Wt. 5 lbs.

Keyway Sizes	Broach Style	Bushing Diameters (Hole Sizes)
1/16	I	1/4, 5/16, 3/8, 7/16, 1/2
3/32	I	
1/8	I	

Standard Set C-1 Collared EDP No. 15318
4 Broaches and 9 Collared Bushings
18 Keyway Combinations Wt. 10 lbs.

Keyway Sizes	Broach Style	Bushing Diameters (Hole Sizes)
1/8	II	1/2, 5/8, 3/4, 7/8
3/16	II	
1/4	III	1, 1-1/8, 1-1/4, 1-3/8, 1-1/2
3/8	III	

Standard Set C-1A Collared EDP No. 15319
4 Broaches and 9 Collared Bushings
18 Keyway Combinations Wt. 10 lbs.

Keyway Sizes	Broach Style	Bushing Diameters (Hole Sizes)
1/8	II	9/16, 11/16, 13/16
3/16	II	
1/4	III	15/16, 1-1/16, 1-3/16, 1-5/16, 1-7/16, 1-9/16
3/8	III	

Standard Set C-2 Collared EDP No. 15320
3 Broaches and 9 Collared Bushings
15 Keyway Combinations Wt. 10 lbs.

Keyway Sizes	Broach Style	Bushing Diameters (Hole Sizes)
1/8	II	9/16, 11/16, 13/16
3/16	III	
1/4	III	15/16, 1-1/16, 1-3/16, 1-5/16, 1-7/16, 1-9/16

Standard Set C-2A Collared EDP No. 15321
3 Broaches and 9 Collared Bushings
14 Keyway Combinations Wt. 10 lbs.

Keyway Sizes	Broach Style	Bushing Diameters (Hole Sizes)
1/8	II	1/2, 5/8, 3/4, 7/8
3/16	III	
1/4	III	1, 1-1/8, 1-1/4, 1-3/8, 1-1/2

Keyway Broach Sets- Metric

Keyway Range; 2mm - 8mm



Precision Set #10 Collared EDP No. 15410

2 Broaches and 5 Collared Bushings
10 Keyway Combinations Wt. 5 lbs.

Keyway Sizes	Broach Style	Metric Bushing Diameters (Hole Sizes mm)
2mm	I	6, 7, 8, 9, 10
3mm	I	

Metric Set #40 Collared EDP No. 15440

6 Broaches and 18 Collared Bushings
36 Keyway Combinations Wt. 12 lbs.

Keyway Sizes	Broach Style	Metric Bushing Diameters (Hole Sizes mm)
2mm	I	8, 10
3mm	I	
4mm	II	12, 14, 16, 18
5mm	II	
6mm	III	18, 19, 20, 22, 24, 25, 26, 28, 30, 32, 34, 36
8mm	III	

Metric Set #18 Collared EDP No. 15418

4 Broaches and 9 Collared Bushings
18 Keyway Combinations Wt. 10 lbs.

Keyway Sizes	Broach Style	Metric Bushing Diameters (Hole Sizes mm)
4mm	II	12, 14, 16, 18
5mm	II	
6mm	III	20, 22, 24, 26, 28
8mm	III	

Metric Set #24 Hardwood EDP No. 15224

3 Broaches and 8 Plain Bushings
24 Keyway Combinations Wt. 36 lbs.

Keyway Sizes	Broach Style	Metric Bushing Diameters (Hole Sizes mm)
10mm	IV	34, 36, 38, 40, 42, 44, 46, 48
12mm	IV	
14mm	IV	

Metric Set #12 Hardwood EDP No. 15212

2 Broaches and 6 Plain Bushings
12 Keyway Combinations Wt. 70 lbs.

Keyway Sizes	Broach Style	Metric Bushing Diameters (Hole Sizes mm)
16mm	IV	54, 56, 58, 60, 62, 64
18mm	IV	

Metric Set #30 Hardwood EDP No. 15230

3 Broaches and 17 Plain Bushings
29 Keyway Combinations Wt. 100 lbs.

Keyway Sizes	Broach Style	Metric Bushing Diameters (Hole Sizes mm)
14mm	IV	44, 46, 48, 50
16mm	V	52, 54, 55, 56, 58, 60,
18mm	V	62, 64, 65, 66, 68, 70



Shims

Collared Bushing



Plain Bushing

QUICK-RESPONSE
FAX FORM
LOCATED ON INSIDE OF BACK COVER



Combination Sets- in Dura Case Boxes



Dura Case Broach Kits

Meeting the needs of today's industry, Hassay Savage broaches find use wherever precision broaching operations add to the quality and economical manufacture of identical parts.

All broaches are CNC-qualified.

American Standard Sets

Standard Set C-10 Collared EDP No. 15336

4 Broaches and 18 Collared Bushings
36 Keyway Combinations Wt. 16 lbs.

Keyway Sizes	Broach Style	Bushing Diameters (Hole Sizes)
1/8	II	1/2, 9/16, 5/8, 11/16, 3/4, 13/16, 7/8
3/16	II	
1/4	III	15/16, 1, 1-1/16, 1-1/8, 1-3/16, 1-1/4, 1-5/16, 1-3/8, 1-7/16, 1-1/2, 1-9/16
3/8	III	

Standard Set C-10A Collared EDP No. 15330

3 Broaches and 18 Collared Bushings
30 Keyway Combinations Wt. 16 lbs.

Keyway Sizes	Broach Style	Bushing Diameters (Hole Sizes)
1/8	II	1/2, 9/16, 5/8, 11/16, 3/4, 13/16, 7/8
3/16	III	
1/4	III	15/16, 1, 1-1/16, 1-1/8, 1-3/16, 1-1/4, 1-5/16, 1-3/8, 1-7/16, 1-1/2, 1-9/16

DIN Standard For Keyways

Keyway Size	Bushing Diameter mm
2mm	6 - 8mm
3mm	8 - 10mm
4mm	10 - 12mm
5mm	12 - 17mm
6mm	17 - 22mm
8mm	22 - 30mm
10mm	30 - 38mm
12mm	38 - 44mm
14mm	44 - 50mm
16mm	50 - 58mm
18mm	58 - 65mm
20mm	65 - 75mm
22mm	75 - 85mm
24mm	85 - 95mm
25mm	85 - 95mm



DIN Standard Metric Sets

EDP No. 15440 DIN

6 Broaches and 13 Collared Bushings
26 Keyway Combinations Wt. 12 lbs.

Keyway Sizes	Broach Style	Bushing Diameters (Hole Sizes mm.)
2mm	I	8, 10
3mm	I	
4mm	II	12, 14, 15, 16
5mm	II	
6mm	III	18, 20, 22, 24, 25, 28, 30
8mm	III	

EDP No. 15410 DIN

2 Broaches and 5 Collared Bushings
10 Keyway Combinations Wt. 5 lbs.

Keyway Sizes	Broach Style	Bushing Diameters (Hole Sizes mm.)
2mm	I	6, 7, 8, 9, 10
3mm	I	

EDP No. 15418 DIN

4 Broaches and 9 Collared Bushings
18 Keyway Combinations Wt. 10 lbs.

Keyway Sizes	Broach Style	Bushing Diameters (Hole Sizes mm)
4mm	II	12, 14, 15, 16
5mm	II	
6mm	III	18, 20, 22, 24, 25
8mm	III	

EDP No. 15224 DIN

3 Broaches and 7 Plain Bushings
21 Keyway Combinations Wt. 12 lbs.

Keyway Sizes	Broach Style	Bushing Diameters (Hole Sizes mm.)
10mm	IV	32, 35, 38, 40, 42, 45, 50
12mm	IV	
14mm	IV	

EDP No. 15212 DIN

2 Broaches and 5 Plain Bushings
10 Keyway Combinations Wt. 5 lbs.

Keyway Sizes	Broach Style	Bushing Diameters (Hole Sizes mm.)
16mm	V	52, 55, 58, 60, 65
18mm	V	



Heavy Duty Keyway Sets



Tongue and Grooved Hardwood Cases

Standard Set 3-D Hardwood EDP No. 15024

4 Broaches and 8 Plain Bushings
32 Keyway Combinations

Wt. 50 lbs.

Keyway Sizes	Broach Style	Bushing Diameters (Hole Sizes)
5/16	IV	1-1/2, 1-5/8, 1-3/4, 1-7/8, 2, 2-1/8, 2-1/4, 2-1/2
3/8	IV	
7/16	IV	
1/2	IV	

Standard Set 3-DA Hardwood EDP No. 15124

4 Broaches and 8 Plain Bushings
32 Keyway Combinations

Wt. 50 lbs.

Keyway Sizes	Broach Style	Bushing Diameters (Hole Sizes)
5/16	IV	1-7/16, 1-9/16, 1-11/16, 1-13/16, 1-15/16, 2-3/16, 2-7/16, 2-15/16
3/8	IV	
7/16	IV	
1/2	IV	

Heavy Duty Set 4-E Hardwood EDP No. 15012

2 Broaches and 6 Plain Bushings
12 Keyway Combinations

Wt. 74 lbs.

Keyway Sizes	Broach Style	Bushing Diameters (Hole Sizes in.)
5/8	V	2-3/8, 2-1/2, 2-5/8
3/4	V	2-3/4, 2-7/8, 3

Heavy Duty Set 4-F Hardwood EDP No. 15014

2 Broaches and 6 Plain Bushings
12 Keyway Combinations

Wt. 74 lbs.

Keyway Sizes	Broach Style	Bushing Diameters (Hole Sizes in)
5/8	V	2-5/16, 2-7/16, 2-9/16
3/4	V	2-11/16, 2-13/16, 2-15/16

Heavy Duty Set 5 Hardwood EDP No. 15026

3 Broaches and 17 Plain Bushings
26 Keyway Combinations

Wt. 175 lbs.

Keyway Sizes	Broach Style	Bushing Diameters (Hole Sizes in.)
1/2	IV	2, 2-1/16, 2-1/8, 2-3/16
		2-1/4, 2-5/16, 2-3/8, 2-7/16
5/8	V	2-1/2, 2-9/16, 2-5/8, 2-11/16
3/4	V	2-3/4, 2-13/16, 2-7/8, 2-15/16, 3

QUICK-RESPONSE
FAX FORM
LOCATED ON INSIDE OF BACK COVER

American Standard Sizes Keyway Broaches

Bushings

Shims

	Broach	EDP No.	Keyway Width Tolerance	Dimensions (in.)	No. of Shims	Length of Cut		Pressure Required for Max. l/c (lbs.)	Bushings			Shims			
						Min.	Max.		Dia.	length	EDP Collared	Size	Thick.	Length x width	EDP No.
I	1/16-I	10104	.0625 - .0635	1/8 x 5-1/4	0	13/64	1-1/8	270	1/4	1-1/8	20116	1/8-I	.031	1-3/8 x 1/8	30108
	3/32-I	10106	.0932 - .0947	1/8 x 5-1/4	0	13/64	1-1/8	810	5/16	1-1/8	20120				
	1/8-I	10108	.1250 - .1262	1/8 x 5-1/4	1	13/64	1-1/8	720	3/8	1-1/8	20124				
									7/16	1-1/8	20128				
									1/2	1-1/8	20132				
II	3/32-II	10206	.0937 - .0947	3/16 x 7	0	19/64	1-11/16	990	1/2	1-11/16	20232	1/8-II	.031	1-7/8 x 3/16	30208
	1/8-II	10208	.1252 - .1262	3/16 x 7	1	19/64	1-11/16	780	9/16	1-11/16	20236	5/32-II	.042	1-7/8 x 3/16	30210
	5/32-II	10210	.1564 - .1574	3/16 x 7	1	19/64	1-11/16	1,560	5/8	1-11/16	20240	3/16-II	.050	1-7/8 x 3/16	30212
	3/16-II	10212	.1877 - .1887	3/16 x 7	1	19/64	1-11/16	2,100	11/16	1-11/16	20244				
									3/4	1-11/16	20248				
									13/16	1-11/16	20252				
									7/8	1-11/16	20256				
III	3/16-III	10312	.1877 - .1887	3/8 x 11-7/8	1	13/32	2-1/2	1,440	3/4	2-1/2	20348	3/16-III	.050	2-7/8 x 3/8	30312
	1/4-III	10316	.2502 - .2512	3/8 x 11-7/8	1	13/32	2-1/2	2,580	13/16	2-1/2	20352	1/4-III	.062	2-7/8 x 3/8	30316
	5/16-III	10320	.3127 - .3137	3/8 x 11-7/8	1	13/32	2-1/2	4,200	7/8	2-1/2	20356	5/16-III	.078	2-7/8 x 3/8	30320
	3/8-III	10324	.3755 - .3765	3/8 x 11-7/8	2	13/32	2-1/2	3,600	15/16	2-1/2	20360	3/8-III	.062	2-7/8 x 3/8	30324
									1	2-1/2	20364				
									1-1/16	2-1/2	20368				
									1-1/8	2-1/2	20372				
									1-3/16	2-1/2	20376				
									1-1/4	2-1/2	20380				
									1-5/16	2-1/2	20384				
									1-3/8	2-1/2	20388				
									1-7/16	2-1/2	20392				
									1-1/2	2 1/2	20396				
								1-9/16	2 1/2	20400					
IV	5/16-IV	10420	.3127 - .3137	9/16 x 13-7/8	1	3/4	6	9,250	1-7/16	4	21492	5/16-IV	.078	6-1/4 x 9/16	30420
	3/8-IV	10424	.3755 - .3765	9/16 x 13-7/8	2	3/4	6	8,000	1-1/2	4	21496	3/8-IV	.062	6-1/4 x 9/16	30424
	7/16-IV	10428	.4380 - .4390	9/16 x 13-7/8	2	3/4	6	11,750	1-9/16	4	21500	7/16-IV	.075	6-1/4 x 9/16	30428
	1/2-IV	10432	.5006 - .5016	9/16 x 13-7/8	3	3/4	6	11,000	1-5/8	4	21504	1/2-IV	.062	6-1/4 x 9/16	30432
	9/16-IV	10436	.5630 - .5640	9/16 x 13-7/8	3	3/4	6	11,100	1-11/16	4	21508	9/16-IV	.062	6-1/4 x 9/16	30436
									1-3/4	4	21512				
									1-13/16	5	21516				
									1-7/8	5	21520				
									1-15/16	5	21524				
									2	5	21528				
									2-1/16	5	21532				
									2-1/8	5	21536				
									2-3/16	5	21540				
									2-1/4	5	21544				
									2-5/16	5	21548				
									2-3/8	6	21552				
									2-7/16	6	21556				
									2-1/2	6	21560				
									2-9/16	6	21564				
									2-5/8	6	21568				
								2-11/16	6	21572					
								2-3/4	6	21576					
								2-13/16	6	21580					
								2-7/8	6	21584					
								2-15/16	6	21588					
								3	6	21592					
V	5/8-V	10540	.6260 - .6270	3/4 x 15-1/4	4	3/4	6	11,500	2-5/16	6	21688	5/8-V	.062	6-3/4 x 3/4	30540
	3/4-V	10548	.7515 - .7525	3/4 x 15-1/4	5	3/4	6	13,500	2-3/8	6	21692	3/4-V	.062	6-3/4 x 3/4	30548
									2-7/16	6	21696				
									2-1/2	6	21700				
									2-9/16	6	21704				
									2-5/8	6	21708				
									2-11/16	6	21712				
									2-3/4	6	21716				
									2-13/16	6	21720				
									2-7/8	6	21724				
								2-15/16	6	21728					
								3	6	21732					
VI	7/8-VI	10656	.8765 - .8775	1 x 19-1/4	6	3/4	6	11,000	special order in dia.			7/8-VI	.062	6-3/4 x 1	30656
	1-VI	10664	1.0015 - 1.0025	1 x 19-1/4	7	3/4	6	14,000	sizes 3-1/4" - 4-1/2".			1-VI	.062	6-3/4 x 1	30664
	1-1/8	10666	1.1260 - 1.1270	1-1/8 x 23	8	3/4	6	15,750				1-1/8	.062	7 x 1-1/8	30740
	1-1/4	10668	1.2510 - 1.2520	1-1/4 x 23	9	3/4	6	14,500				1-1/4	.062	7 x 1-1/4	30750
	1-3/8	10670	1.3760 - 1.3770	1-3/8 x 23	10	3/4	6	19,250				1-3/8	.062	7 x 1-1/4	30760
	1-1/2	10672	1.5020 - 1.5030	1-1/2 x 23	11	3/4	6	21,000				1-1/2	.062	7 x 1-1/4	30770

EDP Bushings I, II and III Numbers 20116 - 20400 are **collared**.
EDP Bushings IV and V Numbers 21492 - 21732 are **plain**

Metric Sizes Keyway Broaches

Bushings

Shims

Standard Metric Keyway Broaches: **ISO J-9** Tolerance

	Broach	EDP No.	J-9 Keyway Width Tolerance	For Standard Millimeter Keys	Dimen. in In.	No. of Shims	Length of Cut		Pressure Required for Max. l/c (lbs.)	Bushings			Shims				
							Min.	Max.		Size	Dim. In.	EDP No.	Size	Thick.	Length x width	EDP No.	
I	2mm-I	11102	.0782 - .0792	2mm x 2mm	1/8 x 5-1/4	0	13/64	1-1/8	510	6mm-I	.2362	22106	3mm-I	.031	1-3/8 x 1/8	31103	
	3mm-I	11103	.1176 - .1186	3mm x 3mm	1/8 x 5-1/4	1	13/64	1-1/8	720	7mm-I	.2756	22107					
										8mm-I	.315	22108					
										9mm-I	.3543	22109					
										10mm-I	.3937	22110					
II	4mm-II	11204	.1570 - .1580	4mm x 4mm	1/4 x 7	1	19/64	1-11/16	1,140	11mm-II	.4331	22211	4mm-II	.038	1-7/8 x 1/4	31205	
	5mm-II	11205	.1963 - .1973	5mm x 5mm	1/4 x 7	1	19/64	1-11/16	2,040	12mm-II	.4724	22212	5mm-II	.050	1-7/8 x 1/4	31205	
										13mm-II	.5118	22213					
										14mm-II	.5512	22214					
										15mm-II	.5905	22215					
										16mm-II	.6299	22216					
										17mm-II	.6693	22217					
										18mm-II	.7087	22218					
										19mm-II	.7480	22219					
III	5mm-III	11305	.1963 - .1973	5mm x 5mm	3/8 x 11-7/8	1	13/32	2-1/2	1,680	17mm-III	.6693	22317	5mm-III	.047	2-7/8 x 3/8	31305	
	6mm-III	11306	.2357 - .2367	6mm x 6mm	3/8 x 11-7/8	1	13/32	2-1/2	1,890	18mm-III	.7087	22318	6mm-III	.062	2-7/8 x 3/8	31306	
	7mm-III	11307	.2751 - .2761	7mm x 7mm	3/8 x 11-7/8	1	13/32	2-1/2	2,985	19mm-III	.748	22319	7mm-III	.062	2-7/8 x 3/8	31307	
	8mm-III	11308	.3145 - .3155	8mm x 7mm	3/8 x 11-7/8	1	13/32	2-1/2	3,995	20mm-III	.7874	22320	8mm-III	.078	2-7/8 x 3/8	31308	
										22mm-III	.8661	22322					
										24mm-III	.9449	22324					
										25mm-III	.9842	22325					
										26mm-III	1.0236	22326					
										27mm-III	1.063	22327					
										28mm-III	1.1024	22328					
										30mm-III	1.1811	22330					
										32mm-III	1.2598	22332					
										34mm-III	1.3386	22334					
										35mm-III	1.3779	22335					
IV	10mm-IV	11410	.3932 - .3942	10mm x 8mm	9/16 x 13-7/8	2	3/4	6	8,100	36mm-III	1.4173	22336	10mm-IV	.056	6-1/4 x 9/16	31410	
	12mm-IV	11412	.4720 - .4730	12mm x 8mm	9/16 x 13-7/8	2	3/4	6	10,550	32mm-IV	1.2598	22432	12mm-IV	.056	6-1/4 x 9/16	31412	
	14mm-IV	11414	.5509 - .5519	14mm x 9mm	9/16 x 13-7/8	2	3/4	6	11,090	34mm-IV	1.3386	22434	14mm-IV	.062	6-1/4 x 9/16	31414	
										35mm-IV	1.3779	22435					
										36mm-IV	1.4173	22436					
										38mm-IV	1.4961	22438					
										40mm-IV	1.5748	22440					
										42mm-IV	1.6535	22442					
										44mm-IV	1.7323	22444					
										45mm-IV	1.7716	22445					
										46mm-IV	1.811	22446					
										48mm-IV	1.8898	22448					
										50mm-IV	1.9685	22450					
										52mm-IV	2.0472	22452					
V	16mm-V	11516	.6296 - .6306	16mm x 10mm	3/4 x 15-1/4	3	3/4	6	11,375	54mm-IV	2.126	22454	16mm-V	.062	6-3/4 x 3/4	31516	
	18mm-V	11518	.7083 - .7093	18mm x 11mm	3/4 x 15-1/4	3	3/4	6	12,000	55mm-IV	2.1653	22455	18mm-V	.062	6-3/4 x 3/4	31518	
										56mm-IV	2.2047	22456					
										58mm-V	2.2835	22558					
										60mm-V	2.3622	22560					
										62mm-V	2.4409	22562					
										64mm-V	2.5197	22564					
										65mm-V	2.559	22565					
										66mm-V	2.5984	22566					
										68mm-V	2.6772	22568					
										70mm-V	2.7559	22570					
										72mm-V	2.8346	22572					
	VI	20mm-VI	11620	.7873 - .7883	20mm x 12mm	1 x 19-1/4	3	3/4	6	11,000				20mm-VI	.062	6-3/4 x 1	31620
		22mm-VI	11622	.8659 - .8669	22mm x 14mm	1 x 19-1/4	4	3/4	6	11,200				22mm-VI	.062	6-3/4 x 1	31622
24mm-VI		11624	.9448 - .9458	24mm x 14mm	1 x 19-1/4	4	3/4	6	13,075				24mm-VI	.062	6-3/4 x 1	31624	
25mm-VI		11625	.9848 - .9858	25mm x 14mm	1 x 19-1/4	4	3/4	6	13,275				25mm-VI	.062	6-3/4 x 1	31625	
28mm		11628	1.1030 - 1.1040	28mm x 14mm	1-1/8 x 23	5	3/4	6	14,700				28mm	.062	7 x 1	31628	
30mm		11630	1.1817 - 1.1827	30mm x 14mm	1-1/4 x 23	5	3/4	6	15,700				30mm	.062	7 x 1	31630	
32mm		11632	1.2605 - 1.2615	32mm x 14mm	1-1/4 x 23	5	3/4	6	16,790				32mm	.062	7 x 1-1/4	31632	
36mm		11636	1.4180 - 1.4190	36mm x 14mm	1-7/16 x 23	5	3/4	6	18,590				36mm	.062	7 x 1-1/4	31636	

Keyway Broaches - Metric

Optional Metric Keyway Broaches: ISO P9 Tolerance

	Broach	EDP No.	P9 Tolerance	For Standard Millimeter Keys	Dimensions in In.	No. of Shims	Length of Cut		Pressure Required for Max. I/c (lbs.)
							Min.	Max.	
I	2mm-I	11102P9	.0785 - .0775	2mm x 2mm	1/8 x 5-1/4	0	13/64	1-1/8	510
	3mm-I	11103P9	.1179 - .1169	3mm x 3mm	1/8 x 5-1/4	1	13/64	1-1/8	720
II	4mm-II	11204P9	.1570 - .1558	4mm x 4mm	1/4 x 7	1	19/64	1-11/16	1,140
	5mm-II	11205P9	.1964 - .1952	5mm x 5mm	1/4 x 7	1	19/64	1-11/16	2,040
III	5mm-III	11305P9	.1964 - .1952	5mm x 5mm	3/8 x 11-7/8	1	13/32	2-1/2	1,680
	6mm-III	11306P9	.2357 - .2345	6mm x 6mm	3/8 x 11-7/8	1	13/32	2-1/2	1,890
IV	8mm-III	11308P9	.3144 - .3130	8mm x 7mm	3/8 x 11-7/8	1	13/32	2-1/2	3,995
	10mm-IV	11516P9	.3931 - .3917	10mm x 8mm	3/16 x 13-7/8	3	3/4	6	11,375
V	12mm-IV	11518P9	.4717 - .4701	12mm x 8mm	3/16 x 13-7/8	3	3/4	6	12,000
	14mm-IV	11414P9	.5498 - .5489	14mm x 9mm	3/16 x 13-7/8	3	3/4	6	11,375
VI	16mm-V	11516P9	.6292 - .6276	16mm x 10mm	3/4 x 15-1/4	3	3/4	6	11,375
	18mm-V	11518P9	.7080 - .7064	18mm x 11mm	3/4 x 15-1/4	3	3/4	6	12,000
VI	20mm-VI	11620P9	.7865 - .7845	20mm x 12mm	1 x 19-1/4	3	3/4	6	11,000
	22mm-VI	11622P9	.8653 - .8633	22mm x 14mm	1 x 19-1/4	4	3/4	6	11,200
VI	24mm-VI	11624P9	.9435 - .9430	24mm x 14mm	1 x 19-1/4	4	3/4	6	13,075
	25mm-VI	11625P9	.9835 - .9815	25mm x 14mm	1 x 19-1/4	4	3/4	6	13,275

NOTE:

Standard metric tolerances are to ISO J9 and JS9. Preferred metric limits and fits --ANSI B4.2-1978.

Optional metric tolerances are available to ISO P9. The ISO P9 option listed on this page utilizes the same bushings and shims as the Standard J-9 metric broaches listed on the previous page.

Standard broaches may be ordered through your nearest Hassay Savage industrial distributor for off-the-shelf-delivery. When ordering from our standard stock, specify the EDP number with type and size as listed in the appropriate table

For all metric keyway broaches:

EDP Bushings I,II and III Numbers 22106 - 22336 are collared.
EDP Bushings IV and V Numbers 22432 - 22572 are plain.



Hassay Savage mm VI Bushing for mm VI Broaches are available on special order in diameter sizes 85mm to 150mm.

Required shims are supplied for each metric keyway broach. When ordering additional or replacement shims, **specify EDP number**. Shims correspond to metric broach size, **not** to bushing size.

One Pass Keyway Broaches

One Pass Keyway Broaches American Standard

	Broach	EDP No.	Keyway Width Tolerance	Dimensions (in.)	Length of Cut		Pressure Required for Max. I/c (lbs.)
					Min.	Max.	
II	1/8-II	10208-COP**	.1252 - .1262	3/16 x 10-3/4	1/4	1-1/2	780
	5/32-II	10208-COP**	.1564 - .1574	3/16 x 10-3/4	1/4	1-1/2	1,370
	3/16-II	10210-OP*	.1877 - .1887	3/16 x 10-3/4	1/4	1-1/2	1,930
III	3/16-III	10312-COP**	.1877 - .1887	3/8 x 18-1/2	5/16	1-11/16	1,090
	1/4-III	10316-COP**	.2502 - .2512	3/8 x 18-1/2	5/16	1-11/16	1,840
	5/16-III	10320-COP**	.3127 - .3137	3/8 x 18-1/2	5/16	1-11/16	2,860
	3/8-III	10324-OP**	.3755 - .3765	3/8 x 18-1/2	5/16	1-11/16	4,030

One Pass Metric Keyway Broaches to ISO H9 Tolerance

	Broach	EDP No.	Keyway Width Tolerance	For Standard Millimeter Keys	Dim. (in.)	Length of Cut		Pressure Required for Max. I/c (lbs.)
						Min.	Max.	
I	3mm-I	11103-OP*	.1185 - .1190	3mm x 3mm	1/8 x 8-1/2	1/4	1-1/8	780
II	4mm-II	11204-COP**	.1581 - .1585	4mm x 4mm	1/4 x 10-3/4	1/4	1-1/2	1,370
	5mm-II	11205-COP**	.1975 - .1979	5mm x 5mm	1/4 x 10-3/4	1/4	1-1/2	1,930
III	6mm-III	11306-COP**	.2372 - .2376	6mm x 6mm	3/8 x 18-1/2	5/16	1-11/16	1,090
	8mm-III	11308-COP**	.3159 - .3163	8mm x 7mm	3/8 x 18-1/2	5/16	1-11/16	1,840

* OP designates one-pass, no chamfer

** COP designates chamfer, one-pass



**Internal Rotary/Punch
Broaches & Plugs**

**Adjustable & Non Adjustable
Rotary Holders**

Internal Rotary/Punch Broaches

Hexagonal Rotary/Punch Broaches

8mm - .315 SHANK - AMERICAN			
EDP No.	Hex Size	Depth of Cut	OAL
66002	.051"	5/64"	1-1/4"
66004	1/16"	3/32"	1-1/4"
66005	5/64"	7/64"	1-1/4"
66006	3/32"	9/64"	1-1/4"
66007	7/64"	5/32"	1-1/4"
66008	1/8"	3/16"	1-1/4"
66009	9/64"	7/32"	1-1/4"
66010	5/32"	1/4"	1-1/4"
66012	3/16"	9/32"	1-1/4"
66014	7/32"	1-1/32"	1-1/4"
66016	1/4"	3/8"	1-1/4"
66018	9/32"	3/8"	1-1/2"
66020	5/16"	3/8"	1-1/2"
66022	11/32"	7/16"	1-1/2"
66024	3/8"	1/2"	1-1/2"
66026	13/32"	1/2"	1-1/2"
66028	7/16"	1/2"	1-1/2"
66030	15/32"	1/2"	1-1/2"

Tin coating available

8mm - .315 SHANK - METRIC			
EDP No.	Hex Size	Depth of Cut	OAL
662013	1.3mm	3/32"	1-1/4"
662015	1.5mm	3/32"	1-1/4"
66202	2mm	7/64"	1-1/4"
662025	2.5mm	5/32"	1-1/4"
66203	3mm	3/16"	1-1/4"
66204	4mm	1/4"	1-1/4"
66205	5mm	5/16"	1-1/4"
66206	6mm	3/8"	1-1/4"
66207	7mm	3/8"	1-1/2"
66208	8mm	3/8"	1-1/2"
66209	9mm	3/8"	1-1/2"
66210	10mm	1/2"	1-1/2"
66211	11mm	1/2"	1-1/2"
66212	12mm	1/2"	1-1/2"

Tin coating available

1/2" - .500 SHANK - AMERICAN			
EDP No.	Hex Size	Depth of Cut	OAL
66106	3/32"	9/64"	1-1/2"
66107	7/64"	5/32"	1-1/2"
66108	1/8"	3/16"	1-1/2"
66109	9/64"	7/32"	1-1/2"
66110	5/32"	1/4"	1-1/2"
66112	3/16"	9/32"	1-1/2"
66114	7/32"	9/32"	1-1/2"
66116	1/4"	3/8"	1-1/2"
66118	9/32"	7/16"	1-1/2"
66120	5/16"	1/2"	1-1/2"
66122	11/32"	9/16"	1-1/2"
66124	3/8"	9/16"	1-1/2"
66126	13/32"	5/8"	2"
66128	7/16"	5/8"	2"
66130	15/32"	5/8"	2"
66132	1/2"	5/8"	2"
66134	17/32"	5/8"	2"
66136	9/16"	5/8"	2"
66138	19/32"	5/8"	2"
66140	5/8"	3/4"	2"
66142	21/32"	3/4"	2"
66144	11/16"	3/4"	2"
66146	23/32"	3/4"	2"
66148	3/4"	7/8"	2"

1/2" - .500 SHANK - METRIC			
EDP No.	Hex Size	Depth of Cut	OAL
66302	2mm	5/32"	1-1/2"
663025	2.5mm	5/32"	1-1/2"
66303	3mm	3/16"	1-1/2"
66304	4mm	1/4"	1-1/2"
66305	5mm	5/16"	1-1/2"
66306	6mm	3/8"	1-1/2"
66307	7mm	1/2"	1-1/2"
66308	8mm	1/2"	1-1/2"
66309	9mm	1/2"	1-1/2"
66310	10mm	9/16"	1-1/2"
66311	11mm	9/16"	2"
66312	12mm	5/8"	2"
66314	14mm	5/8"	2"
66315	15mm	5/8"	2"
66316	16mm	5/8"	2"
66317	17mm	7/8"	2"
66318	18mm	7/8"	2"
66319	19mm	7/8"	2"

3/4" - .750 SHANK - AMERICAN			
EDP No.	Hex Size	Depth of Cut	OAL
66524	3/8"	1/2"	2-1/2"
66528	7/16"	1/2"	2-1/2"
66532	1/2"	5/8"	2-1/2"
66536	9/16"	3/4"	2-1/2"
66540	5/8"	3/4"	2-1/2"
66548	3/4"	7/8"	2-3/4"
66556	7/8"	7/8"	2-3/4"
66564	1"	7/8"	2-3/4"



Applications:

For use with screw machines, CNC turning machines and arbor presses. For use in automotive, aerospace, medical and other various fields.

Other Shanks, Metric, Square, Torx® Octagon & Spline Forms Available, Please Call.

Square Rotary/Punch Broaches

8mm - .315 SHANK - AMERICAN			
EDP No.	Hex Size	Depth of Cut	OAL
68004	1/16"	1/8"	1-1/4"
68006	3/32"	9/64"	1-1/4"
68008	1/8"	3/16"	1-1/4"
68010	5/32"	1/4"	1-1/4"
68012	3/16"	9/32"	1-1/4"
68014	7/32"	11/32"	1-1/4"
68016	1/4"	3/8"	1-1/2"
68018	9/32"	3/8"	1-1/2"
68020	5/16"	3/8"	1-1/2"
68022	11/32"	3/8"	1-1/2"
68024	3/8"	3/8"	1-1/2"

1/2" - .500 SHANK - AMERICAN			
EDP No.	Hex Size	Depth of Cut	OAL
68106	3/32"	9/64"	1-1/2"
68108	1/8"	3/16"	1-1/2"
68110	5/32"	1/4"	1-1/2"
68112	3/16"	9/32"	1-1/2"
68114	7/32"	11/32"	1-1/2"
68116	1/4"	3/8"	1-1/2"
68118	9/32"	7/16"	1-1/2"
68120	5/16"	1/2"	1-1/2"
68122	11/32"	9/16"	1-1/2"
68124	3/8"	5/8"	2"
68128	7/16"	5/8"	2"
68132	1/2"	5/8"	2"
68136	9/16"	3/4"	2"
68140	5/8"	7/8"	2"

3/4" - .750 SHANK - AMERICAN			
EDP No.	Hex Size	Depth of Cut	OAL
68532	1/2"	5/8"	2-1/2"
68536	9/16"	3/4"	2-3/4"
68540	5/8"	3/4"	2-3/4"
68548	3/4"	7/8"	2-3/4"

**QUICK-RESPONSE
FAX FORM**
LOCATED ON INSIDE OF BACK COVER



Adjustable Rotary Broach Holders

Accepts Internal Hex & Square Rotary Broaches Holders

FOR BROACHES WITH 8mm - .315 SHANK				
EDP No.	OAL	Shank Dia.	Shank Length	Broach Shank Depth
P-67040	3-27/64"	5/8"	1-1/2"	9/16"
P-670485	3-59/64"	3/4"	2"	9/16"

FOR BROACHES WITH 3/4" - .750 SHANK				
EDP No.	OAL	Shank Dia.	Shank Length	Broach Shank Depth
P-67072HDS	7-9/16"	3"	1-1/2"	1.250"
P-67076HD	7-9/16"	3"	1-3/4"	1.250"

FOR BROACHES WITH 1/2" - .500 SHANK				
EDP No.	OAL	Shank Dia.	Shank Length	Broach Shank Depth
P-67048	4-17/32"	3/4"	2"	0.742"
P-67064	4-17/32"	1"	2"	0.742"
P-67068	5-17/32"	1 1/4"	3"	0.742"
P-67072	5-17/32"	1 1/2"	3"	0.742"



Applications

Rotary/Punch Broaches can be used in a variety of machines to cut polygons in blind holes: Any type of CNC or manual turning, milling, drilling or screw machine. The practical forming length of a rotary/punch broaching is usually up to 1-1/2 times the size of the broach (measured across flats).

Rotary Broach Holders: For optimal tool life in large production settings these broaches are used in Rotary Broach Holders.

HOLDERS and broaches are sold separately and available from stock for immediate delivery. These holders are for use on any type CNC or manual turning, milling, drilling or screw machine. The holder has an internal live spindle, which holds the end cutting broach tool. The centerline of the cutting tool is offset at 1° from the centerline of the work piece. This causes the broach to wobble creating a shearing effect as the broach is advanced into

the work piece or vice versa as described below:

Broaching a Rotating Work Piece: In a turning or screw machine, the holder is mounted stationary while its internal live spindle and the broach rotates after contact with the rotating work piece (**Diagram A**). At the appropriate feed, the workpiece is "sheared" by the pressure of the broach through a wobbling type action producing the polygon shape desired.

Broaching a Stationary Work Piece: In a milling or drilling machine, the holder is mounted into and rotates with the machine spindle while its internal live spindle along with the broach remains stationary upon contact with the stationary work piece (**Diagram B**). While the machine spindle is rotating, the broach's pressure shears the polygon shape into the work piece (wobbling type action).

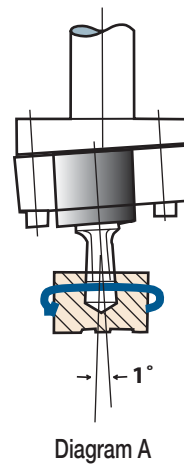

Diagram A

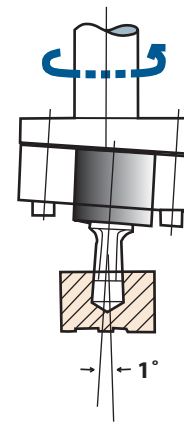

Diagram B

Punching Versus Rotary Broaching: Many applications can be achieved without the rotary broach holder. For the purpose of merely punching a polygon into an existing pilot hole, these broaches have successfully been used with universal machining methods.

For Recommended Use, See Next Page.

Use Recommendations

Part Preparation: The diameter of the pre-drilled hole should be 1-2% larger than the measurement across the flats on the broach. Drill the hole as deep as possible for chip clearance. Countersink with a 90° lead chamfer slightly larger than the largest dimension of the broach face (distance across points).

Centering the Broach: The most critical component in running these tools is having the broach centered as close as possible to the centerline of the work piece. Improper centering will cause uneven hole configurations, oversize holes, spiraling, and excessive cutter/holder wear. It is necessary to align the end of the broach tool to the centerline of the work piece diameter by means of adjusting the screws located on the sides of the holder. Alignment instructions are included with purchase of the tool holder.

Speeds and Feeds: Rotational speed (RPM) has very little effect on cutting speed and tool life. We recommend starting at 800 RPM with a feed rate of .016 times the

size of the broach in inches for a feed rate in IPR units. For example the feed rate for a 1/4" rotary/punch broach would be $0.16 \times .250 = .004"/rev$.

Coolant: The amount of heat generated is minimal. Normal coolant or cutting oil should be applied on the tip of the broaching tool prior to contacting the work piece and not inside of the work piece pilot hole. Trapped fluid may not be able to escape, causing inability to broach to full depth.

Broach Tool Material: Broaches are customarily manufactured from M-2 high-speed steel. This material provides the required edge toughness for standard operations, which do not generate enough heat to effect tool life in machining most metals. However, for broaching materials such as ductile iron, tool steel, stainless steels, titanium alloys, or nickel-cobalt alloys, a cobalt or PM-4 powdered metal broach would be recommended for optimal tool life. Coatings are also available.

Internal Example:

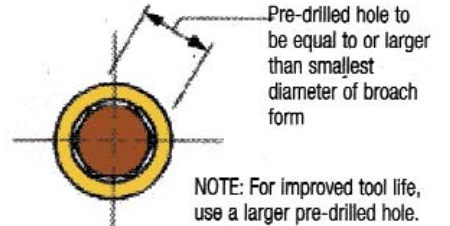
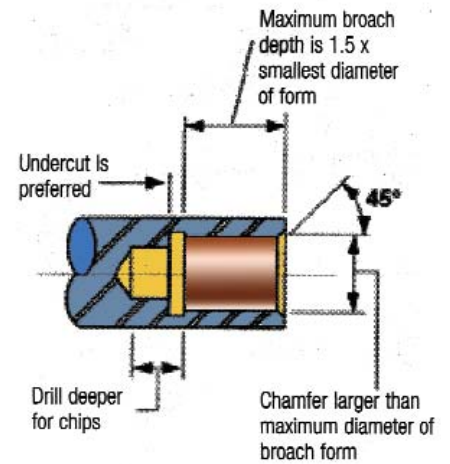

Example:
Hex: $B \times 1.035$
= Pre-drilled hole
s.c. = $B \times 1.1547$

Square: $B \times 1.10$
= Pre-drilled hole
s.c. = $B \times 1.4142$

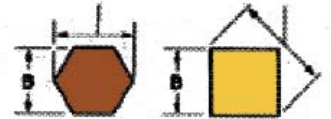

You can successfully broach these shapes & others with Hassay Savage Tools



To request a quote please copy and fax this page to 413-863-2714

BROACH REQUIREMENTS

Size/Shape _____ Depth of Cut _____
 Tolerance +/- _____
 Desired Broach Shank Size _____
 Material to be Machined _____
 Type of Machine _____
 Type of Holder _____

CONTACT INFORMATION

Contact Name _____
 Company Name _____
 Address _____
 Phone # _____ Fax # _____
 Email _____



Rotary Broaching Set-Up Plugs

Rotary Broaching Set-Up Plug Procedure Things You Need to Know for the Perfect Set-up

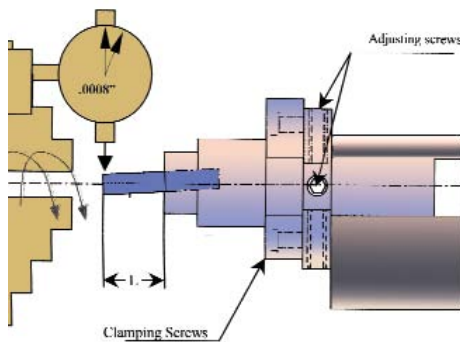

The process of setting up and centering a rotary broach holder for conventional blind hole broaching can sometimes be tedious and difficult for first time users as well as for the experienced operator. We will try to make that experience as effortless as possible, and by developing



some simple set-up procedures for you, we are taking all of the guesswork out of the equation. Please read through our following application notes and realize how a somewhat challenging set-up can be made easy.

Set-up Made Easy

1. Start by placing the rotary tool holder in the turret of a lathe or the tool holder of a milling machine, depending on your application, which machine best fits your process needs.
2. Mount our centering plug in the spindle of the rotary broach tool holder and take care that the plug is bottomed out in the spindle before tightening.
3. Center it on the tool shank with the 3 adjustment screws that are on the spindle using a dial indicator. Reference our hex broaching chapters on our website for visuals of the set-up process:

www.hassay-savage.com.

Size	EDP No.	Plug Diameter (- .001 inches)	Shank Diameter (- .0050 inches)	Depth of Plug (inches)	Overall Length OAL (inches)
1/8	67008	.13	8mm	5/16	1-1/4
3/16	67012	.192	8mm	5/16	1-1/4
1/4	67016	.254	8mm	5/16	1-1/2
3/8	67024	.385	8mm	1/2	1-1/2
1/2	67032	.51	8mm	1/2	1-1/2

8mm Metric Shank

1/2" American Standard Shank

Size	EDP No.	Plug Diameter (- .001 inches)	Shank Diameter (- .0050 inches)	Depth of Plug (inches)	Overall Length OAL (inches)
3/16	67112	.192	.500	5/16	1-1/2
1/4	67116	.254	.500	5/16	1-1/2
3/8	67124	.385	.500	1/2	1-1/2
1/2	67132	.51	.500	1/2	2
5/8	67140	.64	.500	1/2	2

3/4" American Shank

Size	EDP No.	Plug Diameter (- .001 inches)	Shank Diameter (- .0050 inches)	Depth of Plug (inches)	Overall Length OAL (inches)
3/8	67524	.385	.750	1/2	2-1/2
1/2	67532	.51	.750	1/2	2-1/2
5/8	67540	.64	.750	3/4	2-1/2
3/4	67540	.77	.750	3/4	2-1/2

4. Drill and ream or bore a hole .001 - .002 larger for the set-up plug diameter in the material on your machine, with a 90° lead chamfer to allow for alignment.
5. Loosen the 2 clamp screws and the 6 adjustment screws on the flange portion of the body to the shank of the rotary broach holder.
6. Advance the holder with the inserted plug into the reamed hole.
7. **With the plug still engaged in the hole, tighten the 2 clamp screws**
8. Then tighten the 6 adjusting screws.
9. Back the holder out of the reamed hole.
10. Remove the set-up plug and replace with the rotary broach tool, making

sure the broach is bottomed out in the holder, the same as the set-up plug in *Step 2*.

11. Re-center the rotary broach by indicating the same as *Step 3* and start broaching.

We can also supply you with custom "specific turned diameters" for your exact drill and bore size when repeatable set-ups are required for your job on a continuous basis. These will all come with the standard lengths and shank diameters of: 8mm, .500, and .750. Contact our customer service department at **800-247-2024 for pricing and 24 hour delivery service.**

Above are some listings of the standard diameter gauge-plug with specifications that you can purchase from stock inventories to use in standard holders.



1-800-247-2024

Adjustable Rotary Broaching

What are the differences between rotary, Swiss/wobble, punch and index?

Rotary

The tool shape is cut into the customer's part with spindle turning when using a rotary holder system.



The Rotary Holders:

With materials today that make up these component parts ranging from difficult to machine Titanium 6AL 4V and stainless steels like 17-4 PH or 18-8 PH, we offer solutions that maintain consistent process control and longer tool life in the running time. We offer rotary broaching holders in a range from typical commercial applications, to a high end Swiss made rotary holder system for Swiss type CNC machining.

The commercial grade system is an adjustable tool that has to be set-up for centerline by making the holder and spindle run on zero run-out at the point of the tool.

We offer holders that will do .060 (1,5mm) hex to 1.000" (25,4mm) hex holes in steel.

Hex Rotary Broaching can be performed on multiple machining applications, for instance CNC machining centers or transfer machines. For the purpose of this material the proce-

cedure will be performed on a Computer Numerical Control Turning Center.

The broaching holder serves two functions: It holds the broach tool in a free spinning bearing; and, it places the broach tool at a 1° angle relative to the centerline of the workpiece.

There are two types of commonly used holders:

- Adjustable Rotary Broach holder



Coaxial Indicator

Swiss Style or Wobble

- Swiss Non-Adjustable Rotary Broach Holder

The tool shape is cut into the customer's part with spindle turning when using a rotary holder system. This is typical when used on a vertical machining center.

Punch/Index

The shape is cut with the spindle locked in a stationary position, and the broach is then punched into the customer's part.

Index- A broaching process that involves a stationary spindle and

a partial form of the shape that is to be generated. Once hole preparation is completed, the tool form is generated on a Swiss type CNC machine by making imprints of the tool to the proper depth while the part is indexed properly to create the full form desired.

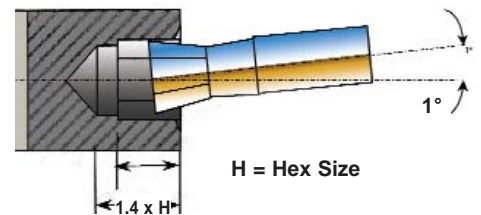

Cutting Principle

The tool is held at a 1° angle relative to the part centerline and has a 1° 30" clearance angle built in. The face of the broach tool is the pivot of the 1° angle and is placed on centerline with the part. As the tool comes in contact with the part, friction drives the broach to rotate synchronously. The cutting edge is kept on center and the rest of the tool oscillates around the part centerline with a wobble effect. With the faces of the tool and part at a relative 1° angle, only the leading point of the tool is cutting and not the entire profile. The wobble effect moves the leading edge to rotate in and out of the cut like a cam. It shears the shape into the part with a scalloping effect as it advances forward. This reduces the required thrust force up to 80% when it is at the optimum feed.

How to Set Up Adjustable Rotary Broach Holder for CNC Machining

Adjustable Rotary Broach Holder Set Up

To complete this procedure you will need the required tooling: Broach Holder; Hex Broach or set up plug, Magnetic base adjustable indicator for bench set up; Coaxial indicator gauge for CNC machine set up

The set up can be completed on the machine, but for efficiency we recommend completing it off-line.

1. First position the shank of the holder into the end of the colleted fixture. If necessary, turn the handwheel on the fixture to increase or decrease the size of the opening to adjust to the size of the shank on the rear of the holder.



2. Insert the end of the holder into the fixture and turn the handwheel to secure the holder.

3. Loosen the two set screws on the front of the holder. Insert the hex broach into the front of the holder with the circular end facing out for ease of indicating, or use set-up plug.

4. Tighten the two set screws to secure the hex broach in place. Retrieve the indicator gauge and position the tip of the gauge on the end of the broach. Zero the indicator before gauging the set up.



5. Turn the handwheel on the fixture while watching the indicator to determine if the broach is aligned on center with the shank of the holder.

6. Readings between .001 and .002 are acceptable limits. Readings above .002 are unacceptable and will require additional adjustments to the holder.

7. There are several adjustment screws on the holder that may need to be adjusted to set the centerline.

8. There are two large allen screws that secure the face of the holder together. Using an allen wrench, loosen each of these.

9. Next to each of these large allen screws are three set

screws. Each one of these set screws acts as a pivot point for the face of the holder. Using an allen wrench, loosen or tighten each one accordingly.



10. Spin complete holder then regauge with the indicator and continue to make the necessary adjustments until the desired reading between .001 - .002 is met. Retighten the two larger allen screws.



11. Remove the hex broach from the holder by loosening the two set screws. Reposition the orientation of the broach with the hex head facing out. Tighten the set screws.

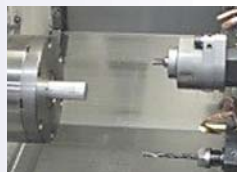

12. This completes the set up of the rotary broach holder. Now the holder can be installed into the appropriate CNC machine for operations.

Note: See our set-up procedure on our website course videos- "Hex rotary broaching."

Rotary and Index Broaching



Market and Process Updates

Improved Technologies for Medical Orthopedic Products & Components

Rotary and index broaching in our industry today is becoming a more consistent part of the manufacturing process as CNC machines become more sophisticated. The Swiss CNC equipment today can even compensate for concentricity of centerline to hole location, which is a major improvement over machines of only a few years ago. The components built in the medical fields today require incredibly close tolerances and strict quality controls like "6-sigma" to get their products to market

Our product is used to hold hex bone screw tolerances of +/- .0005 (0,012mm) for size-- which is difficult to maintain-- in conventional manufacturing environments. To do this, we will maintain a $\pm .0002$ (0,005mm) tolerance on the actual broach. Typical hex sizes range from: 1,5mm, 2,5mm, 3mm, 3,5mm, 4,5mm and 5mm. We have developed a medical hex broach full form range in cobalt based high-speed steel from stock inventories that will allow a customer to get his tools the next day when delivery is critical. In addition, the majority of our tooling supplied in this industry is



our manufactured tooling is considered a special. The amount of "special" tools manufactured every day in our plant is more than our standard line in the orthopedic market. Hassay Savage special tooling is typically delivered in 5-7 days to our customer's specifications. Our CNC-CBN ground tools are always consistent tool to tool.



The Rotary Broach Tooling:

We have been instrumental in serving many sectors of the medical field today as a high quality manufacturer of precision broaching tools to make hex and square forms in orthopedic bone screws,

Special Tolerance and *Special lengths* for a variety of solutions specific to our customer. 60% of

Swiss Style Broach Hexagonal Rotary/Punch Broaches

as well as a full array of other component equipment that is used



.315 shank - American

EDP No. M-2	EDP No. PM M-4	Hex Size	Depth of Cut	OAL
76002	77002	.051	5/64	28mm
76004	77004	1/16	3/32	28mm
76005	77005	5/64	7/64	28mm
76006	77006	3/32	9/64	28mm
76007	77007	7/64	5/32	28mm
76008	77008	1/8	3/16	28mm
76009	77009	9/64	7/32	28mm
76010	77010	5/32	1/4	28mm
76012	77012	3/16	9/32	28mm
76014	77014	7/32	11/32	28mm
76016	77016	1/4	3/8	28mm

.315 shank - Metric

EDP No. M-2	EDP No. PM M-4	Hex Size	Depth of Cut	OAL
762015	772015	1.5mm	3/32	28mm
76202	77202	2mm	7/16	28mm
762025	772025	2.5mm	5/32	28mm
76203	77203	3mm	3/16	28mm
762035	772035	3.5mm	3/16	28mm
76204	77204	4mm	1/4	28mm
762045	772045	4.5mm	1/4	28mm
76205	77205	5mm	5/16	28mm
76206	77206	6mm	3/8	28mm



Non-Adjustable Rotary Broach Holders

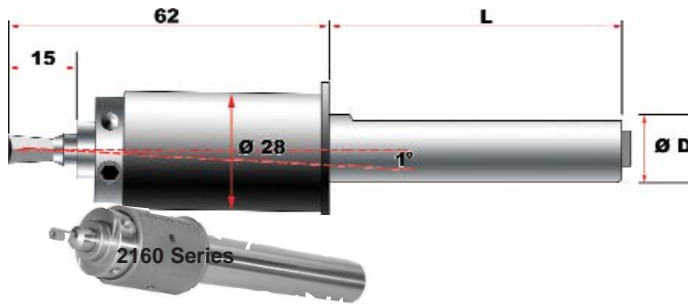

Swiss Style Holders

- No Center Indicating Required
- Smaller Head Diameter Eliminates Interference
- Longer Shank Can Be Cut To Proper Length
- Short Head Length For Limited Back Work Space
- Built In Wobble Cutting Feature 1° Angle
- Heavy Duty Bearing Takes 2250lbs. Pushing Force
- Swiss Made Quality High-Precision
- Fits Most For Swiss Type & Gang Machines

2160 Series Holders

Holds 8mm shank broaches, max. push force 2250 lbs.

Part No. Inch	D	L	Part No. Metric	D	L
HSP-2160-158-038	.625	1.50	HSP-2160-120-038	12	38
HSP-2160-190-100	.750	4.00	HSP-2160-140-038	14	38
HSP-2160-254-120	1.00	4.75	HSP-2160-160-038	16	38
			HSP-2160-200-100	20	100
			HSP-2160-220-100	22	100
			HSP-2160-250-120	25	175

Self Centering

Designed for CNC machines, the new 2100 Series Broach Holder meets the challenge for faster and easier setup by placing the broach tool on center and eliminating the need to indicate the holder.

The cylindrical shank design with Weldon Notch makes the 2100 Series perfect for lathe or machining center applications.

2100 Series Holders

Holds 8mm shank broaches, max. push force 900 lbs.

Part No. Inch	D	L	Part No. Metric	D	L
HSP-2100-58	15.87	38	HSP-2100-16	16	38
HSP-2102	19.05	38	HSP-2101	20	38
HSP-2104	25.4	58	HSP-2103	25	50

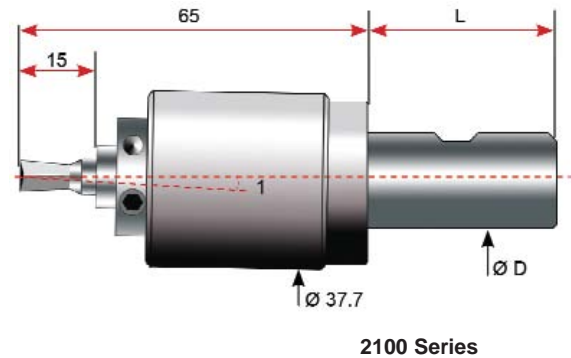

Besides the focus, effort and concentration that we have put into the medical field over the years working with most of the highly respected manufacturers, we have put that same undivided attention into other areas of micro-manufacturing including automotive and aircraft micro

components, and micro precision systems that require high precision tolerance and quality.

It is interesting to note here that all of our product line groups for Hassay Savage and Magafor companies: www.hassay-savage.com; www.magaforusa.com; play an

active and integral role in employing high performance results for those customers who demand not only quality, but also consistent tool life that keeps their machines running longer.

CNC-Single Point Keyway Broaches

A CNC Broaching Alternative

Broaching keyways on CNC machines today is as common as turning a part. It will eliminate part handling and improve your control when you design your process to incorporate short effective nibbling broaches that take the place of much longer tools and sometimes timely set up on secondary machines.

Blind hole and **through hole** CNC keyway broaching with standard tools that are off the shelf, will give you a profitable alternative and save you time.

Blind hole or through hole CNC keyway broaching is achieved through the use of single point nibbling cutters that are designed with two separate cutting surfaces at 180° apart. The one piece construction is created on a high speed tooling blank that is a common size round shank with ground timing flats to align the keyway for timing to the part it is broaching. These tools will offer long tool life, and can be easily sharpened many times for extended tool life. Ideally designed for either CNC lathe or CNC vertical machining centers, these tools can get the job done quickly and effectively:

- For a CNC lathe, the tool is mounted directly into the turret on centerline while a setscrew-locking holder will lock the tool in place and position.
- For a CNC vertical machining center, a collet will hold the tool shank and provide timing orientation.

With the spindle locked, the broach can be brought inline with the pre-prepared bore diameter and chamfer lead of the part to start broaching

The advantages:

- Complete the part on one machine
- Only way to keyway a blind hole
- Cut down on set-up time
- Improve your process
- Become more flexible with machining
- Manage small lot production
- Use cost effective standard tooling
- No bushing guide required
- No hydraulic press or pull required
- No additional operator needed

Keyway Range-
1/8 - 1/2"
4mm - 12mm



We offer a choice of tooling below that accommodates the most frequently made keyways in our markets today for both US and export consumption. We can easily accommodate other keyway sizes as well as those listed. Call us for recommendations on your specific job needs.

Size	EDP No.	Tolerance (inches)	Shank Diameter (inches)	Overall Length OAL (inches)	Max. LOC (inches)
1/8	69008	.1265	.625	3.75	1.50
4mm	69004	.159	.625	3.75	1.50
5mm	69005	.198	.625	3.75	1.50
6mm	69106	.238	.875	4.50	2.00
1/4	69116	.252	.875	4.50	2.00
5/16	69120	.314	.875	4.50	2.00
8mm	69108	.317	.875	4.50	2.00
3/8	69224	.377	1	4.50	2.00
10mm	69210	.396	1	4.50	2.00
12mm	69212	.4745	1	4.50	2.00
1/2	69232	.502	1	4.50	2.00

the keyway at a speed of 10 - 30 in/min and an in-feed of .003 -.005 depth per pass, using a flood coolant for lubrication during the cut. The in-feeding cycle is repeated until the desired depth of the keyway is achieved. Chips can be removed from the bottom of the hole in a couple of ways:

- If the hole is a blind hole bore, remove the chips by either prior trepanning the bottom of the keyway area and allow chips to fall away
- Or pre-drill a hole from the outside to the inside of the part at the bottom of the keyway location.
- With a through hole, you can broach right through, but do not disengage with the part, and simply de-burr the keyway upon completion.

Things That You Should Know:

- Standard tooling will come with common shank diameters.
- The keyway size and length or depth of cut will determine the shank size.
- Strength and rigidity in the set-up will give you longer tool life.
- Consider using the larger shank size to process your jobs.
- Keyway production will achieve excellent finishes and better accuracy.
- **You can design and create your own special tool with our help. Call or see our website chapter on Single Key Broaching.**

Standard Inch Square Push

American Standard

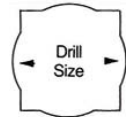

Size Square	EDP No.	Tolerance	Dimension Across Corners	Pilot Diam.	Drill Size	Broach Length	Length of Cut		Pressure for Max. L/C lbs.
							Min.	Max.	
1/8	13008	.1250 - .1260	.1750 - .1770	.1280	#30	4-5/8	3/16	1/2	700
5/32	13010	.1565 - .1575	.2180 - .2200	.1585	#21	5-5/8	1/4	1/2	800
3/16	13012	.1880 - .1890	.2620 - .2640	.1930	#10	5-11/16	1/4	5/8	1,120
7/32	13014	.2190 - .2200	.3050 - .3070	.2275	#1	6-7/8	1/4	3/4	1,580
1/4	13016	.2505 - .2515	.3500 - .3520	.2651	17/64	7	1/4	3/4	1,740
9/32	13018	.2815 - .2825	.3930 - .3950	.2964	19/64	7-1/4	3/8	1	2,300
5/16	13020	.3130 - .3140	.4370 - .4390	.3276	21/64	8-1/8	3/8	1	2,630
11/32	13022	.3440 - .3450	.4810 - .4830	.3589	23/64	9-5/8	3/8	1-1/4	3,050
3/8	13024	.3755 - .3765	.5230 - .5250	.3901	25/64	9-7/8	3/8	1-1/4	3,625
13/32	13026	.4065 - .4075	.5680 - .5700	.4214	27/64	10-7/8	1/2	1-3/8	5,200
7/16	13028	.4385 - .4395	.6110 - .6130	.4526	29/64	11-3/8	1/2	1-3/8	5,700
15/32	13030	.4690 - .4700	.6560 - .6580	.4995	38719	12-1/2	1/2	1-3/8	5,900
1/2	13032	.5005 - .5015	.6970 - .6990	.5307	17/32	12-5/8	1/2	1-3/8	6,000
9/16	13036	.5630 - .5640	.7860 - .7880	.5932	19/32	14-7/8	1/2	1-1/2	6,200
5/8	13040	.6260 - .6270	.8710 - .8730	.6557	21/32	16-13/16	5/8	1-5/8	7,100
11/16	13044	.6885 - .6895	.9610 - .9630	.7495	38780	18-1/2	5/8	1-5/8	7,300
3/4	13048	.7510 - .7520	1.0450 - 1.0470	.8120	13/16	18-7/8	5/8	1-5/8	8,600
7/8	13056	.8765 - .8775	1.2280 - 1.0300	.9370	15/16	22-3/4	1/2	2	12,000
1	13064	1.0020 - 10030	1.4030 - 1.4050	1.0932	1-3/32	24-1/2	1/2	2	12,500

Standard Metric Square Broaches

Size Square	EDP No.	Tolerances* (inches)	Dimensions Across Corners (inches)	Pilot Diameter -.0005 (inches)	Drill Size mm	Broach Length (inches)	Length of Cut (inches)	
							Min.	Max.
4mm	17001	.1580 - .1585	.2080 - .2090	.1655	4.2	5-9/16	5/16	5/8
5mm	17002	.1973 - .1983	.2645 - .2655	.2047	5.2	6-7/8	3/8	3/4
6mm	17003	.2367 - .2377	.3295 - .3300	.2500	6.35	7	3/8	3/4
8mm	17004	.3155 - .3165	.4405 - .4410	.3267	8.3	8-3/16	7/16	7/8
10mm	17005	.3942 - .3952	.5435 - .5445	.4057	10.3	10-7/8	1/2	1
12mm	17006	.4729 - .4739	.6540 - .6550	.4921	12.5	12-1/2	5/8	1-1/4
14mm	17007	.5517 - .5527	.7700 - .7710	.5905	15.0	14-7/8	3/4	1-1/2
16mm	17008	.6310 - .6320	.8780 - .8790	.6693	17.0	16-13/16	7/8	1-3/4
18mm	17009	.7092 - .7102	.9880 - .9890	.7874	20.0	18-1/2	7/8	1-3/4
20mm	17010	.7879 - .7889	1.0990 - 1.100	.8661	22.0	18-7/8	7/8	1-3/4
22mm	17011	.8666 - .8676	1.2110 - 1.2120	.9448	24.0	23-1/4	7/8	1-3/4
24mm	17012	.9454 - .9464	1.3170 - 1.3180	1.0236	26.0	24-9/16	7/8	1-3/4
25mm	17013	.9848 - .9858	1.3730 - 1.3740	1.0630	27.0	24-9/16	7/8	1-3/4

Standard Full Square Push

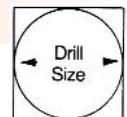

Size Square	EDP No.	Tolerance	Dimension Across Corners	Pilot Diam.	Drill Size	Broach Length	Length of Cut		Pressure for Max. L/C lbs.
							Min.	Max.	
3/16	14012	.1880 - .1890	.2628 - .2632	.1870	3/16	6-1/4	3/16	1/2	1,200
1/4	14016	.2505 - .2515	.3513 - .3517	.2495	1/4	8-5/8	1/4	5/8	1,600
5/16	14020	.3120 - .3140	.4375 - .4380	.3120	5/16	10-1/4	1/4	3/4	2,300
3/8	14024	.3755 - .3765	.5243 - .5247	.3745	3/8	12-1/4	3/8	1	3,750
1/2	14032	.5005 - .5015	.6980 - .6990	.4995	1/2	14-7/16	3/8	1	5,000

Hexagonal Push Broaches

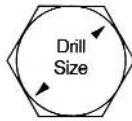

American Standard

Hex Size	EDP No.	Tolerance	Diagonal Dimension	Pilot Diam.	Drill Size	Broach Length	Length of Cut		Pressure for Max. L/C lbs.
							Min.	Max.	
1/8	12008	.1255 - .1260	.1450 - .1470	.1245	1/8	4-5/8	3/16	3/8	120
5/32	12010	.1565 - .1570	.1800 - .1820	.1557	5/32	5-1/2	1/4	1/2	340
3/16	12012	.1880 - .1890	.2145 - .2155	.1870	3/16	5-9/16	1/4	5/8	520
7/32	12014	.2190 - .2200	.2500 - .2520	.2182	7/32	6	1/4	3/4	890
1/4	12016	.2505 - .2515	.2865 - .2875	.2495	1/4	6-1/2	1/4	3/4	1,250
9/32	12018	.2815 - .2825	.3220 - .3240	.2807	9/32	7-3/4	3/8	1	1,650
5/16	12020	.3130 - .3140	.3580 - .3590	.3120	5/16	8-1/4	3/8	1	2,175
11/32	12022	.3440 - .3450	.3950 - .3970	.3432	11/32	8-1/4	3/8	1-1/4	3,500
3/8	12024	.3755 - .3765	.4300 - .4310	.3745	3/8	9	3/8	1-1/4	3,700
13/32	12026	.4065 - .4075	.4670 - .4690	.4057	13/32	10	1/2	1-3/8	4,100
7/16	12028	.4385 - .4395	.5020 - .5030	.4370	7/16	10-3/4	1/2	1-3/8	4,575
15/32	12030	.4690 - .4700	.5390 - .5410	.4682	15/32	12-3/8	1/2	1-3/8	4,700
1/2	12032	.5005 - .5015	.5740 - .5750	.4995	1/2	12-1/2	1/2	1-3/8	5,300
9/16	12036	.5630 - .5640	.6480 - .6500	.5620	9/16	14-1/4	1/2	1-1/2	6,700
5/8	12040	.6260 - .6270	.7170 - .7185	.6245	5/8	16-7/8	5/8	1-5/8	7,250
11/16	12044	.6880 - .6890	.7930 - .7950	.6870	11/16	17	5/8	1-5/8	9,300
3/4	12048	.7510 - .7520	.8610 - .8625	.7495	3/4	17-7/8	5/8	1-5/8	13,500
7/8	12056	.8755 - .8765	1.0060 - 1.0075	.8745	7/8	18-7/8	5/8	1-5/8	18,500
1	12064	1.0020 - 1.0030	1.1520 - 1.1530	.9995	1	19-7/8	5/8	1-5/8	20,050

Metric

Hex Size	EDP No.	Tolerance	Diagonal Dimension	Pilot Diam.	Drill Size	Broach Length	Length of Cut		Pressure for Max. L/C lbs.
							Min.	Max.	
4mm	12104	.1580 - .1585	.1820 - .1830	.1575	4.0	5-1/2	1/4	1/2	340
5mm	12105	.1973 - .1983	.2270 - .2280	.1968	5.0	6	1/4	3/4	890
6mm	12106	.2367 - .2377	.2730 - .2740	.2362	6.0	6-1/2	1/4	3/4	1,250
7mm	12107	.2760 - .2770	.3180 - .3190	.2756	7.0	7-3/4	3/8	1	1,650
8mm	12108	.3155 - .3165	.3634 - .3644	.3150	8.0	8-1/4	3/8	1	2,175
10mm	12110	.3942 - .3952	.4543 - .4553	.3937	10.0	10	1/2	1	4,100
12mm	12112	.4729 - .4739	.5452 - .5462	.4724	12.0	12-3/8	1/2	1-3/8	4,700
14mm	12114	.5517 - .5527	.6332 - .6342	.5512	14.0	14-1/4	1/2	1-3/8	6,700
16mm	12116	.6310 - .6320	.7248 - .7258	.6290	16.0	16-7/8	5/8	1-1/2	7,250
18mm	12118	.7092 - .7102	.8150 - .8180	.7087	18.0	17	5/8	1-5/8	9,400
20mm	12120	.7879 - .7889	.9049 - .9059	.7874	20.0	17-7/8	5/8	1-5/8	14,150
22mm	12122	.8666 - .8676	.9958 - .9968	.8661	22.0	18-7/8	5/8	1-5/8	18,500
24mm	12124	.9454 - .9464	1.0868 - 1.0878	.9449	24.0	19-7/8	5/8	1-5/8	20,500
25mm	12125	.9848 - .9858	1.1323 - 1.1333	.9842	25.0	19-7/8	5/8	1-5/8	22,000

*Tolerance considerations are based on preferred metric limits and fits--ANSI B4.2-1978

NOTES: Hassay Savage standard square and hexagon broaches are HSS push type; designed for one-pass finishing when used with arbor or hydraulic press, or vertical broaching machine.

Special Square and Hexagon Broaches: If your application cannot be handled with the standard hexagon broaches listed, send us a sample or print of the part to be broached.

Include the following data:
Hole: dimensions before and after broaching, with tolerances, and whether cast, drilled or reamed; length required.

Material: specifications, and whether bar, cast or forged stock; appropriate hardness before broaching.

Davis Style Keyseating Broaches

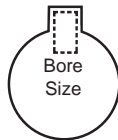

Hassay Savage HSS keyseating pull broaches are manufactured similar to the Davis AF series cutters. Our cutter bars have 10° rake face, 5° back-off and 2° side-relief on all teeth. These broaches may be used on Davis model 4, 5, and 15 machines. Sizes range from 1/16" to 1" and 4mm to 25mm. For special applications contact our customer service.

Why Hassay Savage broaches stand for precision and top quality: The side relief eliminates drag in multiple-pass broaching.

Tooth-relief, using Borazon™ wheels, improves surface finish and extends tool life.

Precision grinding of the rake face insures consistent performance and free cutting action after several sharpenings.

An undercut pilot allows easier entry on each pass.

American Standard

Hex Size	EDP No.	Keyway Width Tolerance (inches)	Dimensions Body Width x Height x Length	Length of Cut	
				Min.	Max.
1/16	10701	.0625 - .0635	3/16 x 3/8 x 16	5/8	1-7/8
3/32	10702	.0937 - .0947	3/16 x 3/8 x 16	5/8	1-7/8
1/8	10703	.1252 - .1262	3/16 x 7/16 x 16	5/8	1-7/8
5/32	10704	.1564 - .1574	3/16 x 1/2 x 16	5/8	1-7/8
3/16	10705	.1877 - .1887	3/16 x 9/16 x 16	5/8	1-7/8
3/16	10706	.1877 - .1887	3/16 x 3/4 x 20	5/8	3-1/8
1/4	10707	.2505 - .2515	1/4 x 3/4 x 16	5/8	1-5/8
1/4	10708	.2505 - .2515	1/4 x 3/4 x 20	5/8	3-1/8
5/16	10709	.3127 - .3137	5/16 x 7/8 x 16	1-1/16	3-3/16
5/16	10710	.3127 - .3137	5/16 x 7/8 x 20	1-1/16	5-3/16
3/8	10711	.3755 - .3765	3/8 x 7/8 x 16	1-1/16	3-3/16
3/8	10712	.3755 - .3765	3/8 x 7/8 x 20	1-1/16	5-5/16
7/16	10713	.4380 - .4390	7/16 x 1 x 16	1-1/16	3-3/16
7/16	10714	.4380 - .4390	7/16 x 1 x 20	1-1/16	5-3/16
1/2	10715	.5006 - .5016	1/2 x 1 x 20	1-1/16	5-3/16
9/16	10716	.5630 - .5640	9/16 x 1 x 20	1-1/16	5-3/16
5/8	10717	.6260 - .6270	5/8 x 1 x 20	1-1/16	5-3/16
3/4	10718	.7515 - .7525	3/4 x 1 x 20	1-1/16	5-3/16
7/8	10719	.8765 - .8775	3/8 x 1 x 20	1-1/16	5-3/16
1	10720	1.0015 - 1.0025	1 x 1 x 20	1-1/16	5-3/16

Metric

Hex Size	EDP No.	Keyway Width Tolerance (inches)	Dimensions Body Width x Height x Length	Length of Cut	
				Min.	Max.
2mm	11701	.0787 - .0792	3/16 x 3/8 x 16	5/8	1-7/8
3mm	11702	.1181 - .1186	3/16 x 3/8 x 16	5/8	1-7/8
4mm	11703	.1575 - .1580	3/16 x 7/16 x 16	5/8	1-7/8
5mm	11704	.1968 - .1973	5mm x 9/16 x 16	5/8	1-7/8
5mm	11705	.1968 - .1973	5mm x 3/4 x 20	5/8	3-1/8
6mm	11706	.2362 - .2367	6mm x 3/4 x 16	5/8	1-7/8
6mm	11707	.2362 - .2367	6mm x 3/4 x 20	5/8	3-1/8
8mm	11708	.3150 - .3155	8mm x 7/8 x 16	5/8	3-3/16
8mm	11709	.3150 - .3155	8mm x 7/8 x 20	1-1/16	3-3/16
10mm	11710	.3937 - .3942	10mm x 7/8 x 16	1-1/16	5-5/16
10mm	11711	.3937 - .3942	10mm x 7/8 x 20	1-1/16	5-5/16
12mm	11712	.4724 - .4730	12mm x 1 x 20	1-1/16	5-5/16
14mm	11713	.5512 - .5519	14mm x 1 x 20	1-1/16	5-5/16
16mm	11714	.6299 - .6306	16mm x 1 x 20	1-1/16	5-5/16
18mm	11715	.7087 - .7093	18mm x 1 x 20	1-1/16	5-5/16
20mm	11716	.7874 - .7883	20mm x 1 x 20	1-1/16	5-5/16
22mm	11717	.8661 - .8669	22mm x 1 x 20	1-1/16	5-5/16
24mm	11718	.9449 - .9458	24mm x 1 x 20	1-1/16	5-5/16
25mm	11719	.9843 - .9853	25mm x 1 x 20	1-1/16	5-5/16

*Tolerance considerations are based on preferred metric limits and fits--ANSI B4.2-1978

**QUICK-RESPONSE
FAX FORM**
LOCATED ON INSIDE OF BACK COVER



500 & 600 Series Pull Type Broaches

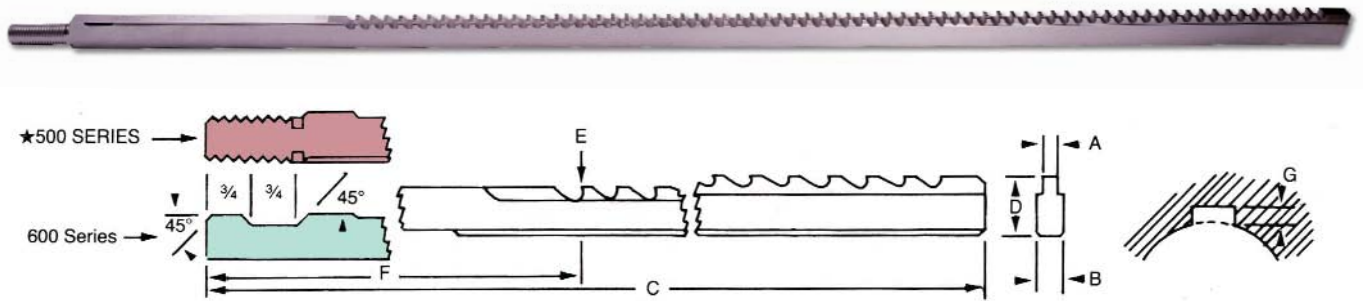

EDP No.	EDP No.	A		Min.	Min.	Max.	B	C	D	E	F	G	No.	Thread
Series	Series	Nom. Dim.	Decimal Dim.	Hole Size	Length Cut**	Length Cut	±.0005	±.0005	±.0005				of Cuts	Size
33501	33601	1/16	.0635	3/8	3/8	1-1/4	.1552	20	.313	.271	7-3/16	.042	1	1/4 - 20
33502	33602	3/32	.0948	7/16	1/2	1-1/2	.1865	24	.367	.309	8-1/4	.058	1	5/16 - 18
33503	33603	3/32	.0948	5/8	5/8	2-1/2	.249	33	.491	.433	10	.058	1	3/8 - 16
33504	33604	1/8	.126	1/2	1/2	1-1/2	.249	30	.438	.364	9	.074	1	3/8 - 16
33505	33605	1/8	.126	7/8	5/8	2-1/2	.3115	36	.594	.520	10	.074	1	1/2 - 13
33506	33606	5/32	.1572	19/32	1/2	1-1/2	.249	30	.525	.436	9	.089	1	3/8 - 16
33507	33607	5/32	.1572	23/32	5/8	2-1/2	.3115	33	.625	.536	10	.089	1	1/2 - 13
33508	33608	3/16	.1885	11/16	5/8	2-1/2	.374	36	.581	.476	10	.1050	1	1/2 - 13
33509	33609	3/16	.1885	15/16	11/16	3-1/2	.374	36	.796	.691	10-11/16	.105	1	1/2 - 13
33510	33610	7/32	.2198	11/16	5/8	2-1/2	.374	33	.557	.437	10	.120	1	1/2 - 13
33511	33611	11/32	.2198	15/16	11/16	3-1/2	.374	42	.813	.693	11-1/16	.120	1	1/2 - 13
33512	33612	1/4	.251	11/16	5/8	2-1/2	.374	36	.612	.476	10	.136	1	1/2 - 13
33513	33613	1/4	.251	1	11/16	4	.499	45	.877	.741	11-13/16	.136	1	5/8 - 11
33514	33614	1/4	.251	1-7/16	7/8	6	.624	51	1.250	1.114	13-1/2	.136	1	3/4 - 10
33515	33615	9/32	.2828	7/8	11/16	4	.499	42	.716	.564	11-5/8	.152	1	5/8 - 11
33516	33616	9/32	.2828	1-1/4	7/8	6	.499	51	1.093	.941	13-1/2	.152	1	5/8 - 11
33517	33617	5/16	.314	1	11/16	4	.499	45	.908	.741	11-13/16	.167	1	5/8 - 11
33518	33618	5/16	.314	1-5/16	7/8	6	.499	51	1.158	.991	13-1/2	.167	1	5/8 - 11
33519	33619	3/8	.3765	1-1/16	11/16	4	.499	45	.938	.739	11-13/16	.199	1	5/8 - 11
33520	33620	3/8	.3765	1-5/16	7/8	6	.499	54	1.189	.990	13-1/2	.199	1	5/8 - 11
33521	33621	7/16	.439	1-9/16	11/16	4	.624	48	1.360	1.160	12	.230	1	3/4 - 10
33522	33622	7/16	.439	2	1	8	.624	48	1.611	1.496	15-5/8	.230	2	3/4 - 10
33523	33623	1/2	.5015	1-1/2	11/16	4	.624	48	1.312	1.051	12	.261	1	3/4 - 10
33524	33624	1/2	.5015	1-1/2	1	8	.624	48	1.377	1.246	16-1/2	.261	2	3/4 - 10
33525	33625	9/16	.5645	1-3/4	11/16	4	.6865	54	1.438	1.146	11-13/16	.292	1	1 - 8
33526	33626	9/16	.5645	1-5/8	1	8	.6865	51	1.391	1.245	16	.292	2	1 - 8
33527	33627	9/16	.5645	2-1/4	1-1/8	12	.874	60	1.641	1.495	20	.292	2	1 - 8
33528	33628	5/8	.627	1-7/8	1-1/16	4	.749	60	1.625	1.301	12-3/16	.324	1	1 - 8
33529	33629	5/8	.627	2-1/2	1	8	.874	54	1.657	1.495	16-3/8	.324	2	1 - 8
33530	33630	5/8	.627	2-1/4	1-1/8	12	.874	57	1.657	1.495	20	.324	2	1 - 8
33531	33631	3/4	.752	1-7/8	11/16	4	.874	60	1.625	1.239	12-3/16	.386	1	1 - 8
33532	33632	3/4	.752	2	1	8	.999	60	1.688	1.495	16-3/8	.386	2	1-1/4 - 7
33533	33633	3/4	.752	2-1/4	1-1/8	12	.999	57	1.688	1.560	20	.386	3	1-1/4 - 7
33534	33634	7/8	.877	2-1/4	11/16	4	1.124	63	1.875	1.426	12-3/8	.449	1	1-1/4 - 7
33535	33635	7/8	.877	2-1/4	1	8	1.124	63	1.719	1.494	15-3/4	.449	2	1-1/4 - 7
33536	33636	7/8	.877	2-1/4	1-1/8	12	1.124	63	1.719	1.569	20	.499	3	1-1/4 - 7
33537	33637	1	1.002	2-1/4	5/8	2-1/2	1.249	63	1.750	1.239	10-1/2	.511	1	1-1/2 - 6
33538	33638	1	1.002	2-1/4	7/8	6	1.249	63	1.750	1.494	14-1/4	.511	2	1-1/2 - 6
33539	33639	1	1.002	2-1/4	1-1/8	12	1.249	60	1.750	1.580	20	.511	3	1-1/2 - 6

*600 Series Designates Notched-Type Shank.

**Minimum length of part recommended to prevent part from dropping in between teeth of broach.

We supply standard pull heads for 500 and 600 Series Broaches upon request. Call us for sizes and delivery.

From the craftsmanship of our toolmakers to the tight standards of our quality control, you can always be assured of

excellent performance from a Hassay Savage HSS broach.

Broaching

The venerable blacksmith will tell you that broaching originated within his craft 3,000 years ago. Needing to create internal spaces within the pieces he hand-forged, the blacksmith invented drifts in varieties of configurations to punch these shapes. Drifts were driven by hammer through the cherry-red hot metal held on the primitive anvil over the pritchel or hardy hole to form a variety of internal shapes.

The industrial historian, however, dates modern broaching back to mid-nineteenth century Germany, where the drifting tool incorporated series of uniform cutting teeth to remove material (much like a wood

rasp). These first broaches were short heavy hand-driven push tools. Initially, internal broaching, such as cutting keyways in pulleys and gears, accounted for the bulk of the work done, and as the power press was developed, applications for internal broaching widened.

Surface broaching evolved more slowly, but by the 1920's became critical in meeting the demands of mass production in the automotive industry. By

the 1930s broaching processes could supply the industry with close-tolerance square holes and multiple splines for transmission gears. The technology continued to develop spiral spline broaching, tooth cutter bars, and broaches manufactured from high-speed steel. By the mid-50's hydraulic, fully automatic internal and external broaching machines were in wide use, making it possible to reduce the cost of mass producing accurately finished identical parts of all shapes and sizes.

Today broaching fixtures typically incorporate mechanical, hydraulic or pneumatic principles and utilize programmable controls and automatic clamping for continuous cycle indexing.

Computers increasingly play a critical role in the design and manufacturing set-up of broach tool-making. The industry also asserts its

competitive edge by taking advantage of significant technical advances in the fields of grinding, coolants, lubricants, stock materials, and heat treatment; which make it possible to produce a tougher, sharper tool at less cost and with faster turnaround.

Since 1969, Hassay Savage Company has emerged as a leader in the development of broaching applications into many areas of manufacturing where there is need to produce precise complex shapes and forms. Forty years later, we are convinced that by joining state-of-the-art technologies with the craft of broaching as it has evolved, modern broaching heads into the twenty-first century as a competitive alternative to reaming, milling, and shaping in operations where critical tolerances at high production speeds in manufacturing identical parts are required.



An automatic broaching operation using Hassay Savage one pass broaches.



Pictured are CNC Push and Strip Broaches for finish sizing automatic slides after rough milling on CNC Tsugami Vertical Mills.



www.hassay-savage.com



1-800-247-2024

Broach Manufacturing at Hassay Savage

We employ strict quality controls for the cutting, milling, heat-treating, and grinding phases. Production involves some 15 to 20 separate operations through our machining departments. Each process involves a skilled toolmaker and a specially fixtured machine to get the job done efficiently and correctly. Because all of our work is scheduled by computer, we have a complete and forward vision of all standard and special orders at each work-station with a scheduled completion date.

We also apply Statistical Process Control (SPC) within our manufacturing process to assure quality broaches. SPC has become a requirement of many of our large Original Equipment Manufacturer (OEM) accounts, such as Ford, GM, Chrysler, General Electric, Caterpillar, and John Deere. Since we conform to documented SPC procedures to satisfy the quality control requirements of these companies, we generate a higher standard of manufacturing throughout our plant for all of our customers.

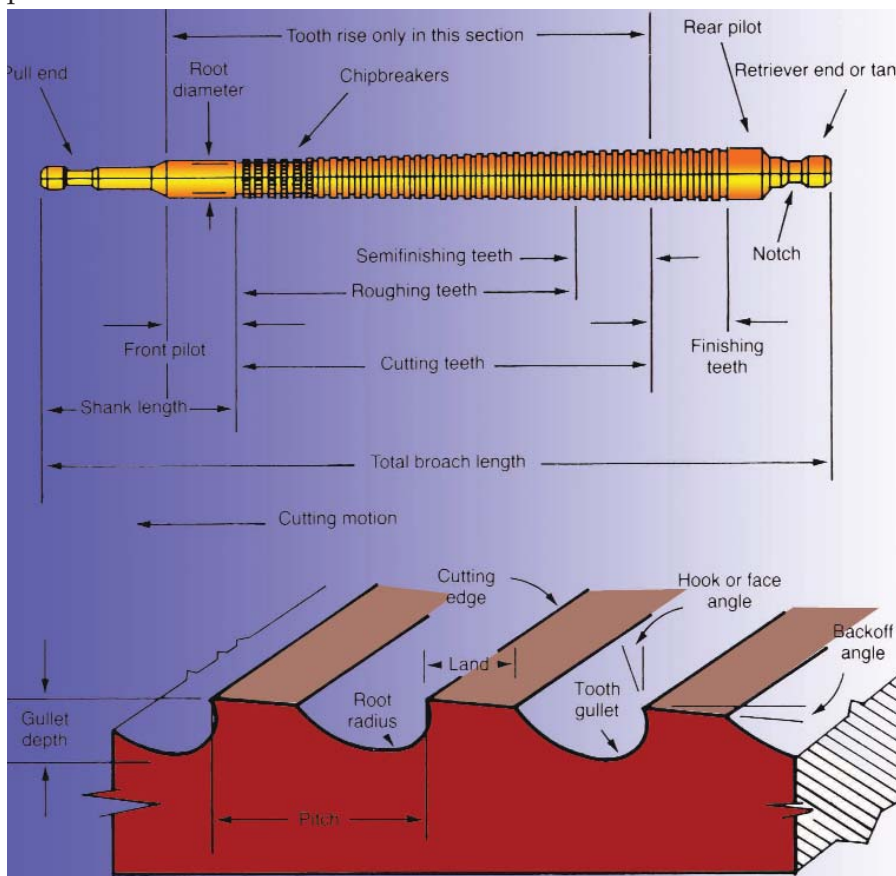
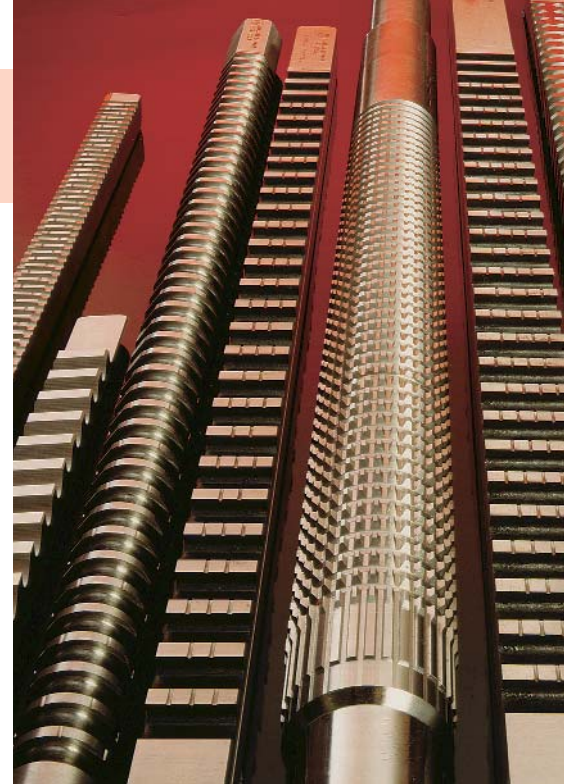

- In creating a more consistent product, we have taken our standard tolerances and made them closer or tighter within our own manufacturing to generate a much more consistent and exacting tool.
- Our skilled toolmakers maintain tolerance variability records on each workstation to scrutinize any variations or changes that may occur in the process and to take immediate corrective action.
- Our quality control lab supervises the inspection process performed at each workstation.
- Complete process control means a better, more consistent broaching tools and more satisfied Hassay Savage customers.

The real secret, however, is in our refined broach grinding process....

Broach Grinding Process



Aggressive cutting action required by grinding at high-material rates in creep-feed mode.

The most significant technological advances offered by Hassay Savage's manufacturing and sharpening equipment are in the actual grinding process. First we cut the basic tooth configuration in hardened tool steel. Because hardened broach materials are difficult to grind, Hassay Savage abandoned the traditional Aluminum Oxide wheel in the early 70s. Switching to CBN wheels at that time nearly doubled our productivity. Technology has now addressed the fact that using CBN wheels on machinery originally designed for slower spindle speeds and less rigid tool holders, as required by the AO wheels, failed to utilize the full potential of the CBN wheel.

Today, we grind our broaches on Walter Helitronic 4 + 5 Axis grinding machine. These CNC machines are controlled by an on-board Pentium™ computer and its high-power, variable

speed spindles are designed specifically for electroplated CBN wheels. These newer CBN wheels are made by machining the reverse of the tooth configuration into a metal core, then bonding a layer of CBN abrasive to this machined surface by electroplating. These CBN wheels, surfaced with Borazon™, require virtually no maintenance; have an exceptional wheel life; and are

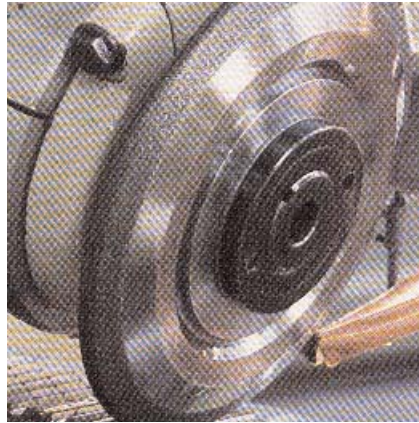

CNC grinding with state-of-the-art CBN wheels means that all broaches-original and resharpened, get the same exacting treatment at Hassay Savage.

capable of holding correct tooth form throughout their long life.

To compensate for the heat generated by the high-speed grinding, the Walter machine uses a straight oil lubricant applied by intense pressure directly to the grinding zone which prevents air-borne droplets from polluting our work atmosphere while at the same time effectively reducing work-piece friction and distortion.

The on-board computer is programmed to produce all of the types of broaches manufactured by Hassay Savage. The programs are used to grind new broaches and to sharpen older broaches returned to us for rebuilding.

By joining the latest CNC and CBN grinding in our manufacturing facility, we offer our customers new or rebuilt broaches held to near-perfect tolerances; broaches capable of extremely accurate cuts and finishes that consistently meet the most exacting specifications, all at reduced cost and faster turnaround time.

Broach grinding and sharpening cycle-times have been reduced 30 to 50 percent in order to get tools back to you sooner.

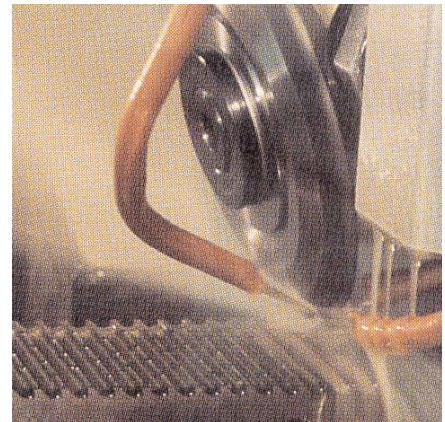

**QUICK-RESPONSE
FAX FORM**
LOCATED ON INSIDE OF BACK COVER

Cost Benefits of a Hassay Savage Broach

It is important to analyze cost savings of any operation when it means more money in your company's pocket. Compared to other operations such as milling, reaming, shaping, and EDM-type contour work, broaching over the long run does the job faster and with unsurpassed precision.

The traditional strength of the broaching process and its tool is now reinforced by innovative technologies that make it a most profitable manufacturing solution. Built into Hassay Savage broaches are the following cost benefits:



The optical Comparator assures that all profile grinding of tooth forms and contours meet our exacting standards.

Flat broaches of up to 4" (101,6mm) wide and 23.5" (596,9mm) long; round broaches up to 4" (101,6mm) in diameter and 65" (1650mm) in length are manufactured on our CNC machines.

- **CNC/CBN-ground tools**
- **Extended broach life**
- **Smoother, more accurate cuts**
- **Better surface finishes**
- **More piece parts per hour, per sharpening**
- **Less frequent replacement**
- **Consistent high quality**
- **Excellent turnaround**

The Broaching Process Comparison Cost

Time-saving in the Broaching Process Increases Production 3 to 5 Times

TYPICAL COMPARISON OF BROACHING VS. MILLING		TYPICAL COMPARISON OF BROACHING VS. SHAPING	
COST PER PIECE	12¢ PER PIECE (BROACHING) \$ 2.25 PER PIECE (MILLING)	COST PER PIECE	\$ 1.00 PER PIECE (BROACHING) \$ 5.00 PER PIECE (SHAPING)
PIECES PER HOUR	400 PCS. PER HOUR (BROACHING) 20 PCS. PER HOUR (MILLING)	PIECES PER HOUR	50 PIECES PER HOUR (BROACHING) 10 PIECES PER HOUR (SHAPING)
TOOL LIFE	12,000-15,000 PCS PER SHARPENING (BROACHING) 400 PCS. PER SHARPENING (MILLING)	TOOL LIFE	1,500 PIECES PER SHARPENING (BROACHING) 100 PIECES PER SHARPENING (SHAPING)
SET UP COST	FIXTURE \$ 100 (BROACHING) VISE & FIXTURE \$ 600 (MILLING)	SET UP COST	HOLDING FIXTURES \$ 700 (BROACHING) VISE & CLAMPING \$ 600 (SHAPING)
COST OF TOOLS	625 x .750 "DD" BROACH \$ 375 (BROACHING) DRILL/END MILLS \$ 150 (MILLING)	COST OF TOOLS	.524 x 1.706 RECT. PUSH BROACH \$ 1,200 (BROACHING) ASSORTED SHAPER TOOL \$ 600 (SHAPING)
START UP COST	3 TON-15" VERTICAL BROACH \$ 9,200 (BROACHING) BRIDGEPORT MILLING MACHINE \$ 15,600 (MILLING)	START UP COST	22" HYDRAULIC BROACH PRESS \$ 10,400 (BROACHING) 24" ROCKFORD SHAPER \$ 16,000 (SHAPING)

Rebuilding & Sharpening

In rebuilding a broach, our CNC machine first examines the entire broach with its touch probe. This procedure accurately locates the face and gullet of each tooth to measure the exact spacing, depth and all its angles. The touch probe compensates for any irregularities stemming from the broach's original tooling.

The probing information on each broach is stored in the CNC machine's memory and is recalled to guide the grinding wheel through the sharpening process. Consistency is maintained with the broach's original grinding, and the cutting job is distributed evenly over the entire tool, sparing the individual teeth from excessive stress. Only the minimum amount of metal (.002-.005 inches) is removed to bring all teeth to exact size while retaining maximum strength on each tooth.

Hassay Savage's own CNC-machined broaches do not require touch probing since their design specifications are already stored for sharpening maintenance. Not only does this capability expedite the broach's rebuilding, but assures that the regrinding will be absolutely accurate. Our broach rebuilding is also accomplished with electroplated Borazon^(™) CBN grinding wheels for critical accuracy and high finish.

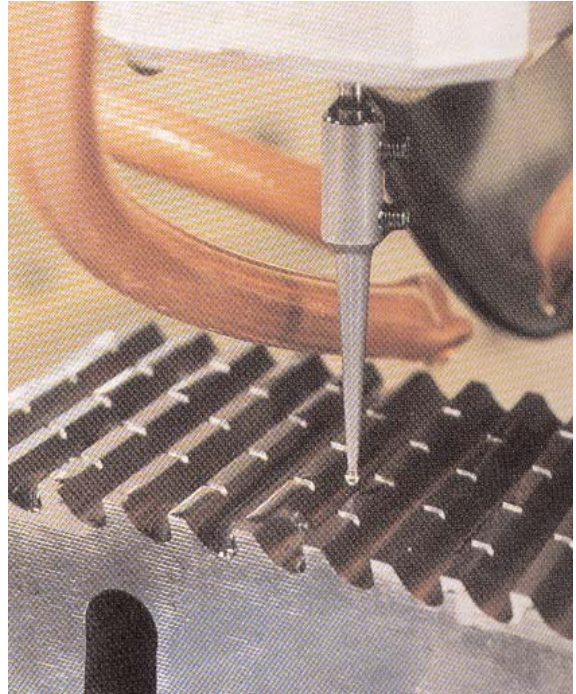

Properly sharpened broaches prolong tool life and keep production costs down. Regular maintenance is built into our service over the life of each Hassay Savage broach. Within one to two weeks' turnaround we rebuild your broaches to peak working efficiency.

The Hassay Savage Method of Reconditioning

Broaches require sharpening when:

- Excessive pressure is necessary to run the broach
- Tearing or poor finish is evident in the part
- Broach begins drifting during broaching
- Chatter occurs during broaching
- Cutting section shows signs of wear

1. Replace broken teeth by welding where necessary.
2. Full form grinding of gullet and face of tooth form.
3. Re-grind tooth crests to remove chips and nicks from teeth.
4. Re-step teeth to proper uniform taper and cutting action.
5. Re-grind existing chipbreakers to give proper chip flow.
6. Relieve tooth crests to provide the proper clearance for achieving good part finished.
7. Full quality control inspection to blueprint.
8. Insert tools are re-marked to compensate to original dimension.

Tool Material Data

Hassay Savage purchases all of its standard material, M-2 HSS, from one steel mill.

This purchasing strategy assures us of a consistency within batch runs that generates uniform product throughout our manufacturing process. Our mill guarantees a quality assurance of 10 to 12 percent higher carbon content in our M-2 HSS. That gives our customers a finished product unsurpassed in the industry. The comparative properties of our material have excellent wear resistance, toughness, and red hardness for the broaching process in most all types of stock including the more difficult materials, such as stainless steel.

We also have available a stock of M-3, M-4, M-42, PM-M4, and PM -T15 high speed steels for all special broach tooling indicated by material application or difficulty of the broaching process. Each high-speed steel lends itself to the special properties of wear resistance, toughness, grindability, and relative red hardness, as shown in the accompanying chart (see also chart on page 33).

Comparative Properties for the Selection and Use of High Speed Steels

ANSI TYPE	Typical Analysis	Relative Wear Resistance	Relative Toughness	Relative Grindability	Relative Red Hardness
M-2	Carbon	0.85			
	Tungsten	6.15			
	Chromium	4.15			
	Vanadium	1.85			
	Molybdenum	5.00			
M-3 ₁	Carbon	1.02			
	Tungsten	6.00			
	Chromium	4.00			
	Vanadium	2.40			
	Molybdenum	5.00			
M-4	Carbon	1.32			
	Tungsten	5.35			
	Chromium	4.50			
	Vanadium	3.85			
	Molybdenum	4.40			
M-42	Carbon	1.08			
	Tungsten	1.50			
	Chromium	3.75			
	Vanadium	1.10			
	Molybdenum	9.50			
	Cobalt	8.00			
T-15	Carbon	1.57			
	Tungsten	12.25			
	Chromium	4.00			
	Vanadium	4.75			
	Molybdenum	0.50			
	Cobalt	5.00			

This technical data provides you a starting point from which to work. Our engineers can recommend tool materials and operating conditions to fit your exact need for process control.

Using Broaches

Three major factors affect the broaching process. Recognition and control of these factors permits a Hassay Savage Broach user to productively realize the accuracy and economy already engineered into our product.

Material to Be Broached

Hardness and composition of the metal determines how effectively a part can be broached. Any material harder than Rockwell 35 (R35) should not be attempted. Brass and bronze may require some slight alteration of tooth crest to prevent drift.

Telltale Signs That Mean Resharpening

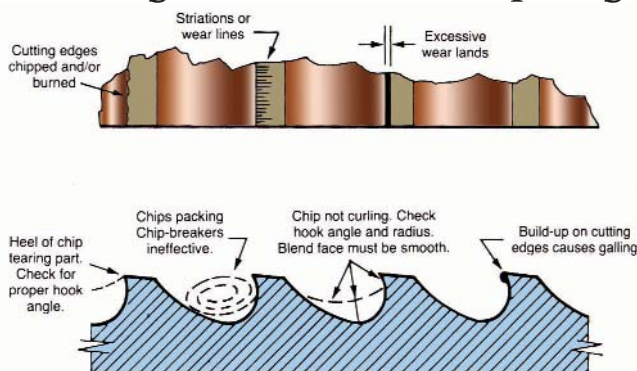

Troubleshooting Broaches

Poor Finish: Material too soft; alignment of broach incorrect; coolant incorrect or improperly applied; dull or poorly sharpened broach.

Chatter Marks: Broach too sharp; coolant incorrect or improperly supplied; lower broach speed required; dull or poorly sharpened broach; tooth space incorrect.

Broach Drifting: Support and alignment of broach incorrect; material too soft; dull or poorly sharpened broach.

Excessive Edge Wear: Abrasive material; coolant incorrect or improperly applied; broaching speed incorrect; incorrect type of HSS.

Chipping: Too little or wrong type of lubricant; tooth spacing may be incorrect for the workpiece's material composition; tool speed too rapid for effective chip removal; chip load too high.

Tool Alignment

Poor alignment will cause tool breakage and drifting which produces a part cut outside accepted tolerances. To insure proper alignment:

1. At least two teeth of the broach should be engaged at all times.
2. Bushings should extend below (or beyond) workpiece to provide appropriate support for the broach.
3. In push broaching, the tool should be centered below the ram so that the ram thrust forces will drive the broach directly through the bushing to avoid drift.
4. An appropriately dimensioned pilot hole should be accurately drilled as a start for the broach tool.
5. Alignment will be adversely affected even when all of the above are correct if the broach tool has become dulled though long use or incorrectly used in materials that were initially too hard. Dull broaches will produce cuts with incorrect tolerances, unacceptable finishes, and will drift out of their intended alignment.

Hassay Savage broaches are provided with a full tang and pilot to ensure proper alignment and a rear guiding section.

QUICK-RESPONSE
FAX FORM
LOCATED ON INSIDE OF BACK COVER

Lubrication

Any cutting process involves friction. Friction causes heat, distortion and vibration; all of which adversely affect the broach cut.

Lubrication of the tool helps reduce friction and, at the same time, assists in chip removal. This guide and the accompanying chart provide general recommendations for lubricants. Our engineers can suggest certain additives for enhanced lubrication. It is important to remember that lubrication can make or break a job.



Straight oil lubricant with additive is applied to reduce friction and heat during the broaching operation.

Lubricant Guide

Steel:	A good grade of cutting oil or water soluble coolant. Cutting oil sprayed on the broach teeth reduces friction on mild steel. Hard steels, especially those containing nickel, may require a chloine additive to a sulfur based cutting oil.
Brass:	Broach brass dry or with water soluble lubricant.
Copper and Bronze:	Oil or water soluble oil is recommended.
Cast Iron:	Broach without lubricants. Use oil to lubricate between broach and shim or bushing.
Aluminum:	Special lubricants required, depending on the nature of the aluminum. Harder varieties may be treated as soft steel. In general, the alloy manufacturer's recommendations for low-speed machining operations should be followed.

High Grade to Low Grade Materials That Are Broachable

Material	Broach Tool Grade	Rake Face Angle	Max. per Tooth Chip Load	Speed PPM*	Coolant
Monel Alloy	PM T-15, PM M4	18°	0.002	12	Oil w/25% Sulfur Add.
Nickel Alloy	PM T-15, PM M4	15°	0.002	10	Oil w/25% Sulfur Add.
Beta Alloy	PM T-15, PM M4	18°	0.002	10	Oil w/25% Sulfur Add.
Titanium Alpha-Beta Alloy	PM T-15, PM M4	14°-18°	0.003	8	Oil w/25% Sulfur Add.
Malleable Cast Iron	PM T-15, PM M4	6°-8°	0.002	10	Oil--No Additive
Stainless Steel	PM T-15, PM M4	18°-20°	0.002	8	Oil w/Sulfur Additive
Stainless Steel Cast	PM T-15, PM M4	18°-20°	0.002	20	Oil w/Sulfur Additive
Stainless Steel Wrought	PM T-15, PM M4	18°-20°	0.003	20	Oil w/Sulfur Additive
Armor & Aircraft Plate	PM T-15, PM M4	12°-15°	0.002	15	Oil w/Sulfur Additive
Tool Steel	PM T-15, PM M4	12°-15°	0.002	10	Oil--No Additive
High Strength Steel	M-2	15°-18°	0.003	20	Oil Base Water Soluble
Free Machining Steel	M-2	12°-15°	0.004	30	Oil Base Water Soluble
Medium Carbon Steel	M-2	12°-15°	0.003	25	Oil Base Water Soluble
Low Carbon Steel	M-2	12°-15°	0.004	30	Oil Base Water Soluble
Aluminum Alloy T-5, T-6	M-2	(T-5)6°-10° (T-6)15°-18°	0.006	40	Oil Base Water Soluble
Magnesium Alloy	M-2	15°-18°	0.006	40	Oil Base Water Soluble
Copper Alloy	M-2	12°-15°	0.005	25	Oil Base Water Soluble
Brass	M-2	0°-3°	0.006	30	Oil Base Water Soluble
Bronze	M-2	0°-3°	0.006	30	None or Water
Plastic	M-2	10°-12°	0.010	30	None or Water
Wax	M-2	0°-3°	0.08	30	None or Water

Special Broaches

Selected Broaching Applications

The following list will give you an idea of the kind of first-rate special broaching that distinguishes our company world-wide. Selected applications are:

- **Metering Valve:** 0.524" x 1.706" rectangle 20" push broach: broached at Hassay Savage with 100% inspection for just-in-time shipments to OEM; job lot of 25,000 pieces.
- **Control Vent Airframe:** 40 slots in rectangle chamber; 1.625" x 6.000"; broach was pull-type on horizontal machine; accuracy of 0.001 required throughout reference of all points; job lot of 100 units.
- **Printing Guide Lever:** 19mm x 1.6mm rectangle 610mm pull broach; bronze workpiece; limited production.
- **Wave Guide:** 1.345" x 2.848" 36" pull broach; job lot of 500 pieces, on continuous basis.
- **Control Pin:** flats and radius slot; insert type slab broaches and radius slot broaching on vertical machine; high volume run.
- **Control Valve:** Double D 14,09mm x 21,69mm pull broach; highly specialized DD hole in titanium material; small volume, annual run.
- **Pliers:** Set of three surface broaches to broach teeth of pliers; open clearance and cut-off section; high volume run.
- **Collets:** 6 slots; 0.093" width; slotting broaches for cutting collet slots on vertical broach; high volume with a great variety of sizes using same broaches.
- **Ratchet Wrench:** Elliptical set of holes for mechanism of ratchet; limited volume run.
- **Internal Spline Gear:** 22-tooth 36" spline pull broach; 24/48 diametral pitch; 20° pressure angle; 2 million pieces per year.
- **Surgical Scissors:** 4" wide, 16" long surface broach; stainless steel workpiece; continuous medium volume run.

**QUICK-RESPONSE
FAX FORM**
LOCATED ON INSIDE OF BACK COVER

www.hassay-savage.com

Research and Development

Integration of design and manufacturing processes at the prototype stage is important for successful precuts. Hassay Savage can save you time and money when our engineers are involved from the outset. We routinely assist the following industries:

*Automotive Aircraft Communication Systems
Electronics Military Farm and Constructions
Aerospace Plastics Ammunitions*

Broaching is expanding into areas opened by state-of-the-art technology. Once limited to the machining of ferrous metals, broaching now is also applicable to non-ferrous metals and non-metallic materials such as plastics, ceramics, and wood products. Broaching is also combining with other processes to create machining centers and flexible manufacturing systems which utilize quick change workpiece tooling and broach tool changing systems. At Hassay Savage we are committed to supporting the exploration of broaching's full potential as it unfolds. We subscribe to the research efforts of Ohio University's Broaching Research Laboratory and with this affiliation we are working on:

- Expert systems for the automation of the broach design process.
- Integrated system for the near-net shape (pre-forming) manufacture of broaching tools.
- A knowledge-based system for yielding maximum allowable cutting force during broaching by creating exacting tooth geometry.
- Computer-aided process of down-loading machining programs to workstations by the actual routing process.
- Procedures that reduce the cost of designing, manufacturing, and rebuilding broaches.

The broach is an unsurpassed unique tool that generates finish shapes in one pass. Broaching has a distinct advantage over other metal cutting operations because of its exacting precision, superb finish, and faster production rates (as much as 25 times higher). Wherever broaches can be utilized, quality and productivity improve significantly. Using the Hassay Savage system gives you the best assurance the industry has to offer.



1-800-247-2024

If you require a special broaching operation, let Hassay Savage create a complete system of broaching that provides an expert engineering solution to your application. When our tooling is being used in your facility, we give you 100 percent technical service and commitment to assure you the built-in profitability of a Hassay Savage broaching tool.

Special Broaches



Ordering

Standard broaches may be ordered through your nearest Hassay Savage industrial distributor for off-the-shelf delivery. When ordering from our standard stock, specify the **EDP number** with **type** and **size** as listed in the appropriate table found on page 5 through 25 of this catalog.

All of Hassay Savage tools are available with titanium nitride coating as a standard product. Please contact our customer service for details.

We guarantee immediate shipment by reliable door-to-door United Parcel Service to any point in the Continental USA,

subject to UPS weight limitations. Other specified air and surface freight companies are available at your request for expedient and express service. Shipments are FOB Turners Falls, MA, unless otherwise stated.

Broaching Machinery Available Through Hassay Savage

We can supply the following American-made machinery:

	Dake 1½ Arbor Press	Dake 1½B Arbor Press	Dake 2½ Arbor Press	CB2-14-7 Hydraulic Press	CB2-22-7 Hydraulic Press	315 Vertical Broach	630 Vertical Broach	1045 Vertical Broach	1560 Horizontal Broach
EDP Number	55004	55006	55008	55204	55206	55315	55330	55345	55360
STROKE	11½"	18¼"	21½"	18"	24"	15"	30"	45"	60"
TONNAGE	3	3	6	7	7	3	6	10	15
HORSEPOWER	Manual	Manual	Manual	7½	7½	5	10	20	30
SPEED (ft. per min.)				12	12	35	33	25	27
COOLANT CAPACITY				15 gals.	15 gals.	23 gals.	35 gals.	35 gals.	20 gals.
SHIPPING WEIGHT	220 lbs.	325 lbs.	450 lbs.	1550 lbs.	1800 lbs.	900 lbs.	3100 lbs.	4000 lbs.	7200 lbs.

Contact our customer service for pricing and technical assistance.

To the Distributor

Hassay Savage broaches offer your customers the benefits of advanced design and the latest market technology in manufacturing. Our strict quality controls and skilled group of toolmakers insure that Hassay Savage broaches cut more precisely, last longer, and wear better to make money for you and your cus-

tomers. Ask our customers about our service record for quality and integrity. We are proud of our worldwide reputation.

Under ISA (Industrial Supply Association) we are organized by their standard numbering system. Hassay Savage Co. Manufacture's Code -- 615948 (Uniform Code Council).



Hassay Savage offers:

- Unsurpassed high-quality products made by experienced toolmakers
- Consistent product mix
- Excellent profit structure
- Timely service
- Pride in what we do
- Experienced craftsmanship

1-800-247-2024



www.hassay-savage.com



Hassay Savage Company Custom Broaching Request Form

24 HR. FAX
(413) 863-2714

PULL ENDS

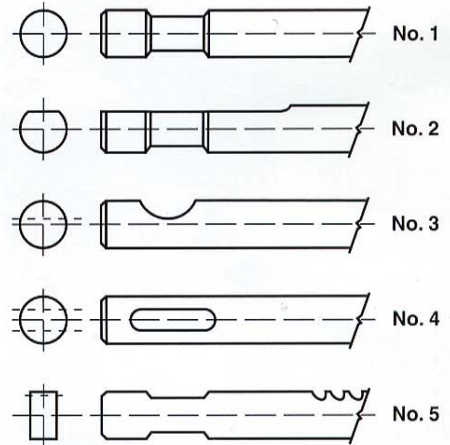

Customer Information

Name:		
Title:		
Company Name:		
Street Address:		
Address-line 2:		
City:	State:	Zip:
Telephone:	FAX:	
E-mail:	Country:	

Broaching Information

Size/Shape of Cut:		
Length of Cut:	Tolerance:	
Material to be Broached:		
Pre-Broaching Condition of Hole/Surface:		
Pilot Hole Size/Shape:		
Minimum Hole Size (for cast holes): (include draft/fillet radii, if any)		
For Keyway Broaches:		
Minimum Bore Size:	Keyway Width:	
Tolerance:		
Depth of Keyway, measured across Bore:		
Type of Broaching Machine:		
<input type="checkbox"/> Push	<input type="checkbox"/> Pull	Tonnage: Ram Travel:
Daylight Opening:		

Please Provide This Information:

Pull End No.
Size
End to 1st Tooth
Starting Hole Size
Finish Size
Length of Cut
Material
Remarks

Involute Information:

Inv. Std.
No. of Splines
Diametrical Pitch
Pressure Angle
Major Dia.
Minor Dia.
Bet. Wires on Hole
Wire Size
Circular T. Thick
Cord. Tooth Thick
Type of Fit
T.I.F. Dia.
Base Circle Dia.
Fillet Rad.
Remarks
Tonnage of Mach.
Stroke of Mach.
Type of Mach.
Model No. of Mach.



Hassay Savage Company

10 Industrial Boulevard
Turners Falls, MA 01376-2251

TEL: (413) 863-9371
FAX: (413) 863-2714

TOLL FREE: 1-800-247-2024

email: info@hassay-savage.com
www.hassay-savage.com

magafor

TEL: (413) 863-9052
FAX: (413) 863-9058

TOLL FREE: 1-800-665-6734
TOLL FREE FAX: 1-866-308-7471
email: barbara@magaforusa.com
www.magaforusa.com