

Supermini® & Mini

Carbide Grooving Tools



Supermini® & Mini - Carbide Grooving Tools



Copyright © Paul Horn GmbH





Dear customer,

We are pleased to introduce our new catalog of **Supermini®** and **Mini Carbide grooving tools**.

This catalog represents part of the most comprehensive range of grooving products available from any single manufacturer.

For more than 40 years, HORN has dedicated its resources to the design and manufacture of tooling specifically for grooving applications.

As a HORN user, you gain access to this wealth of experience in grooving. Our team of engineers will be pleased to give you the help and assistance necessary to ensure you get the very best performance from our products.

If you require any further assistance or information, please do not hesitate to contact us. We look forward to our continued cooperation.

Yours sincerely

A handwritten signature in black ink that reads 'Lothar Horn'.

Lothar Horn



- A Supermini® Type 105**
Boring, Grooving, Chamfering, Threading, Face Grooving
- B Supermini® Type 110**
Boring, Grooving, Face Grooving
- C Mini Type 108**
Boring, Grooving, Chamfering, Threading
- D Mini Type 10P**
Grooving
- E Mini Type 111**
Boring, Grooving, Chamfering, Threading
- F Mini Type 11P**
Grooving
- G Mini Type 114**
Boring, Grooving, Chamfering, Threading, Face Grooving
- H Mini Type 116**
Boring, Grooving, Chamfering, Threading
- J Mini Type 18P**
Grooving
- K Examples for machining**
- L Technical Instructions, Additional equipment**

A

B

C

D

E

F

G

H

J

K

L

HCG - HORN Catalog Guide

Bore Ø	Product line								
	105	110	108	10P	111	11P	114	116	18P
≥ .008" (0.2 mm)	•								
≥ .236" (6.0 mm)	•	•							
≥ .268" (6.8 mm)	•	•							
≥ .307" (7.8 mm)		•	•						
≥ .315" (8.0 mm)		•	•						
≥ .346" (8.8 mm)				•					
≥ .354" (9.0 mm)		•	•	•					
≥ .386" (9.8 mm)					•	•			
≥ .394" (10.0 mm)		•		•	•				
≥ .419" (10.5 mm)						•			
≥ .433" (11.0 mm)					•	•			
≥ .492" (12.5 mm)							•		
≥ .551" (14.0 mm)							•	•	
≥ .630" (16.0 mm)								•	
≥ .650" (16.5 mm)							•		
≥ .689" (17.5 mm)									•

Groove depth ≤ (inch)	.098"	.157"	.039"	.118"	.091"	.138"	.256"	.169"	.315"
Groove depth ≤ (mm)	2.5	4.0	1.0	3.0	2.3	3.5	6.5	4.3	8.0
Width of groove inch	.020"-.079"	.039"-.250"	.029"-.079"	.039"-.118"	.029"-.125"	.039"-.118"	.029"-.125"	.029"-.157"	.071"-.118"
Width of groove mm	0.5 - 2.0	1.0 - 6.35	0.74 - 2.0	1.0 - 3.0	0.74 - 3.18	1.0 - 3.0	0.74 - 3.18	0.74 - 4.0	1.8 - 3.0

Application	Product line								
	105	110	108	10P	111	11P	114	116	18P
Grooving	•	•	•	•	•	•	•	•	•
Boring	•	•	•	•	•	•	•	•	•
Threading	•		•		•		•	•	
Chamfering	•		•		•		•	•	
Face Grooving	•	•					•		
Hard turning	•		•		•		•	•	

Chapter	A	B	C	D	E	F	G	H	J
---------	----------	----------	----------	----------	----------	----------	----------	----------	----------

Special tools upon request

Toolholder system



Page A4-A9

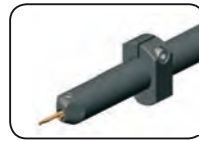

Page A10



Page A11

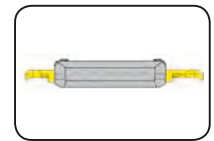

Page A12-A14

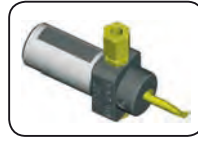

Page A16-A17



Page A18-A19



Page A20

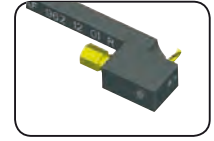

Page A22-A24

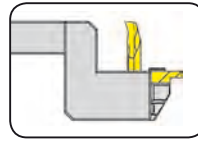

Page A25



Page A26-A27

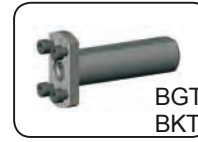

Page A28-A32

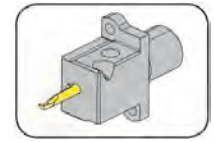

Page A33

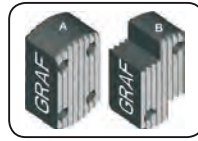

Page A34-A39



Page A40-A44



Page A46



Page A47-A48



Page A49-A55

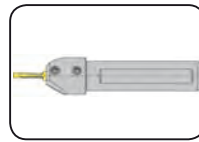

Page A112-A113



Page A116-A117
for extended shanks

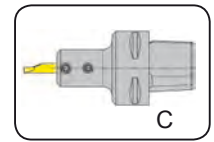

Page A118
for extended shanks

Inserts
U105 / 105
≥ Ø .008" (0.2 mm)

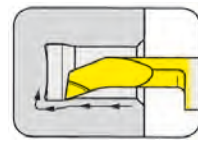

Page A56-A71

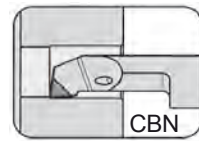

Page A72

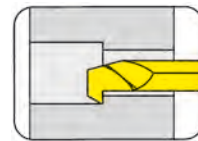

Page A73

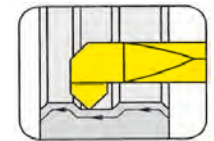

Page A74

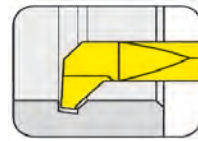

Page A75

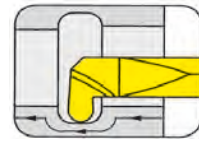

Page A76-A91

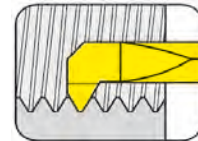

Page A92-A103

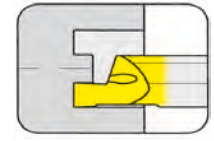

Page A104-A110

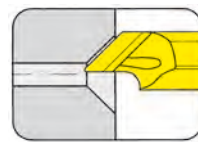

Page A111

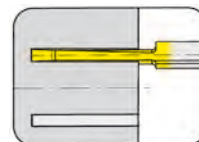

Page A114

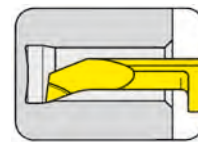

Page A119
extended shanks

Boring from
.008" (0.2 mm)

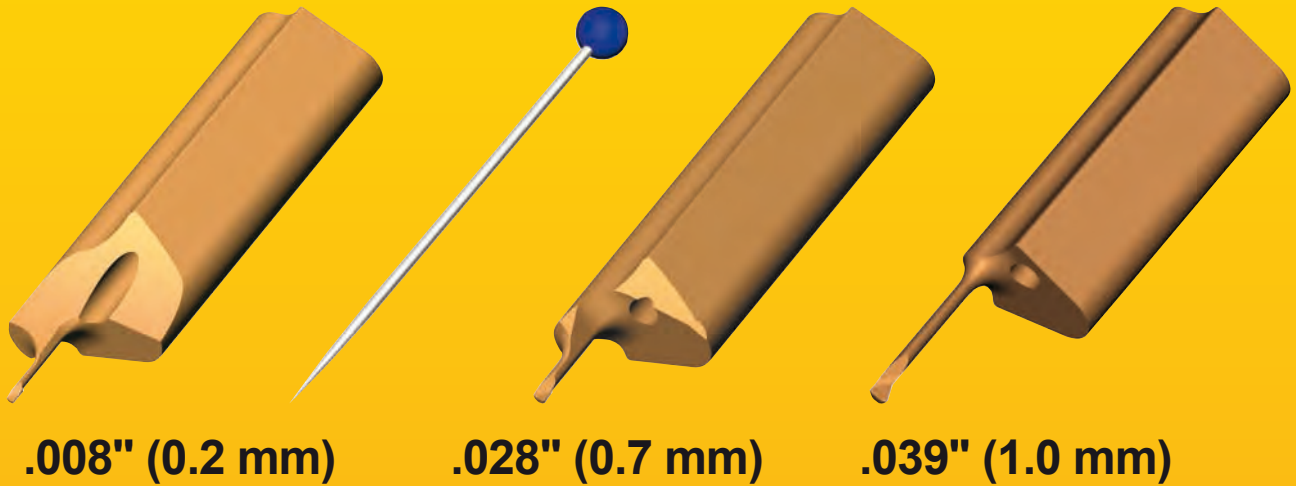

Supermini[®]
- best in small bores -

Grooving, boring, face grooving, threading $\geq \text{Ø } .008''$ (0.2 mm)

The same toolholder can be used for all inserts

Type 105

- special shaped backend of inserts guarantees accurate center height and indexability without resetting the machine
- through coolant supply
- enlarged backend of inserts gives a rigid clamping and good vibration resistance

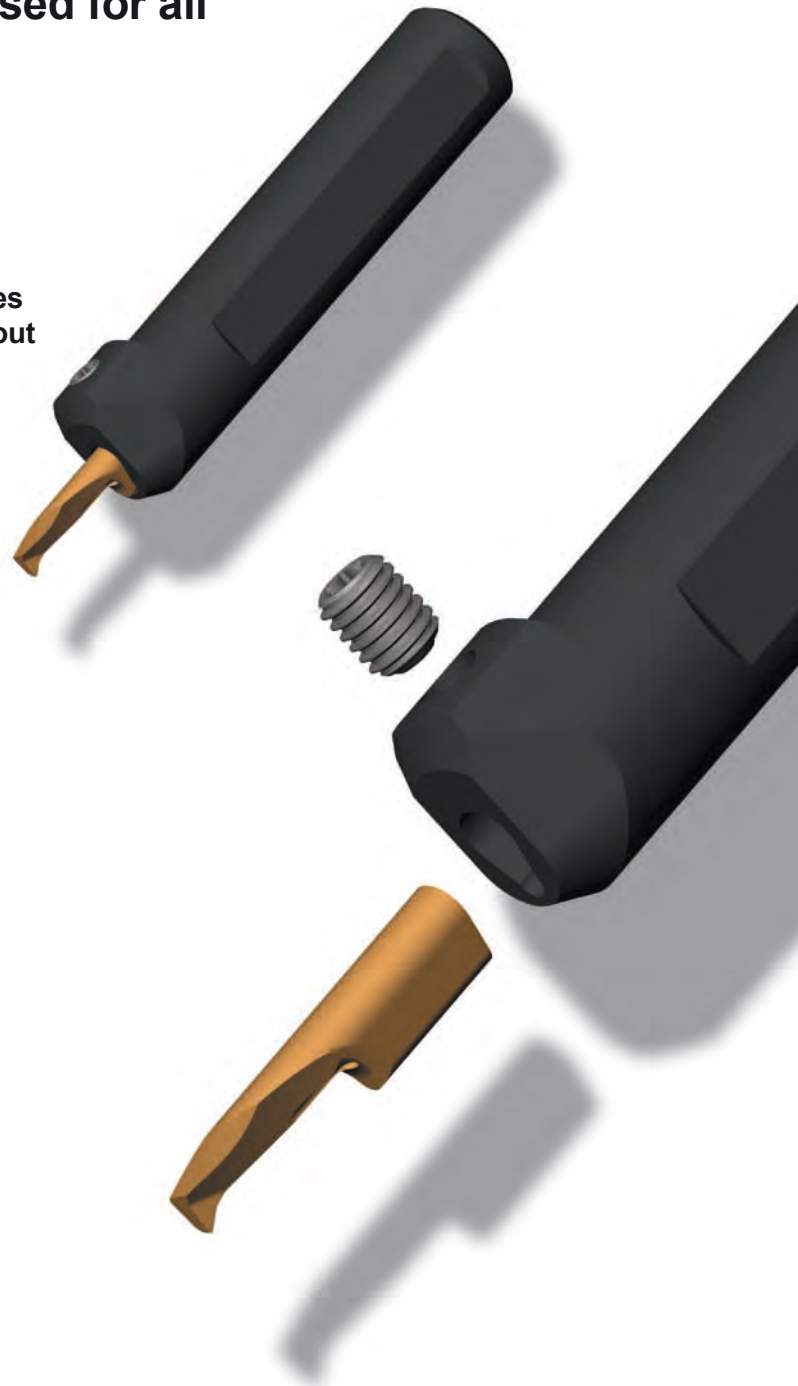

TOOLHOLDER Type

BU105

with through coolant supply

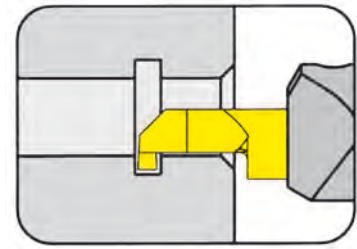

Bore Ø from	.008"
Depth of groove up to	.098"
Width of groove up to	.079"

for use with Insert

Type 105
U105

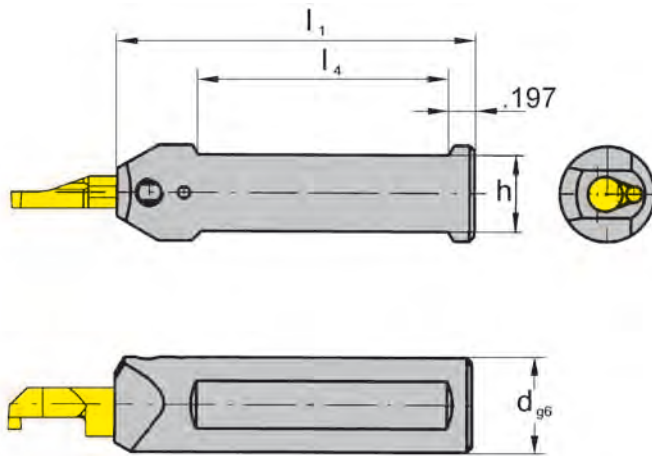

Picture = right hand cutting version shown

Part number	d	l ₁	h	l ₄
BU105.0500.01	.500	2.950	.433	2.160
BU105.0625.01	.625	2.950	.551	2.160
BU105.0750.01	.750	3.540	.671	2.750
BU105.1000.01	1.000	3.540	.921	2.750

Further sizes upon request

Dimensions in inch

Ordering note:

Toolholders can be used with right and left hand inserts.

Spare parts

Toolholder	Screw	TORX PLUS® Wrench
BU105....	6.075T15P	T15PQ

TOOLHOLDER Type

B105

with through coolant supply

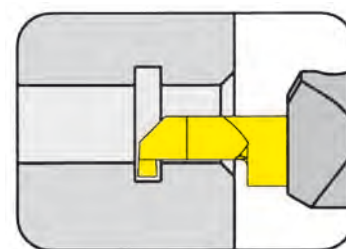

Bore Ø from	.008" (0.2 mm)
Depth of groove up to	.098" (2.5 mm)
Width of groove up to	.079" (2.0 mm)

for use with Insert

Type 105
U105

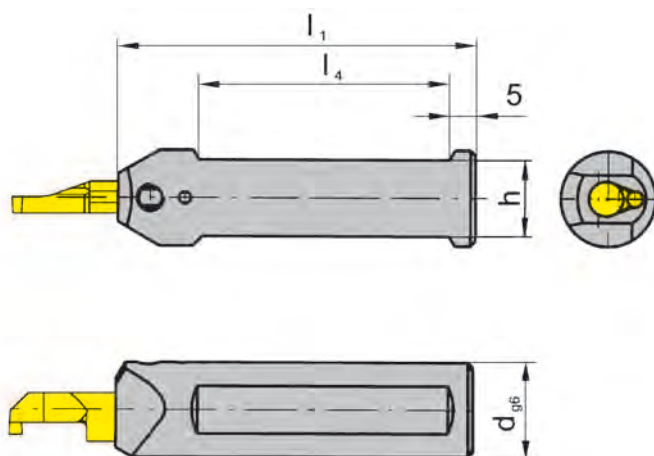

Picture = right hand cutting version shown

Part number	d	l ₁	h	l ₄
B105.0010.01	10	75	9	50
B105.0012.01	12	75	11	50
B105.0016.01	16	75	14	50
B105.0020.01	20	90	18	55
B105.0025.01	25	100	23	55

Further sizes upon request

Dimensions in mm

Ordering note:

Toolholders can be used with right and left hand inserts.

Spare parts

Toolholder	Screw	TORX PLUS® Wrench
B105.00...	6.075T15P	T15PQ

TOOLHOLDER Type

B105/BU105

with through coolant supply

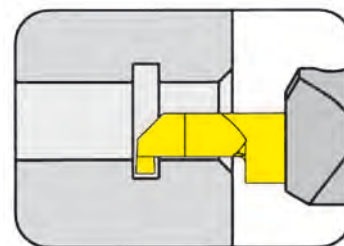

Bore Ø from	.008" (0.2 mm)
Depth of groove up to	.098" (2.5 mm)
Width of groove up to	.079" (2.0 mm)

for use with Insert

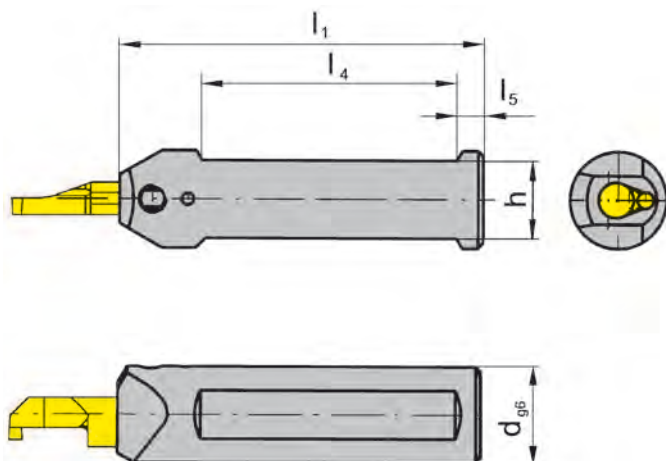
Type 105
U105

Picture = right hand cutting version shown

Part number	d	l ₁	h	l ₄	l ₅	Remark
B105.0022.01	22.00	90.0	20.00	55	5	-
B105.0028.01	28.00	120.0	26.00	72	12	**
BU105.0750.5.01	3/4"	90.0	17.04	70	5	**
BU105.0750.5.3.01	3/4"	152.5	17.05	70	5	**
BU105.1000.5.01	1"	90.0	23.40	65	5	**
BU105.1000.5.3.01	1"	152.5	23.40	70	5	**

Further sizes upon request

Dimensions in mm

** Adapter of cooling M12x1,5 for Traub

Ordering note:

Toolholders can be used with right and left hand inserts.

Spare parts

Toolholder	Screw	TORX PLUS® Wrench
B/BU105...	6.075T15P	T15PQ

TOOLHOLDER Type

B105

with through coolant supply

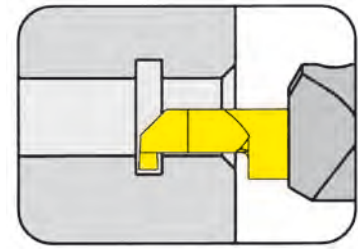

Bore Ø from	.008" (0.2 mm)
Depth of groove up to	.098" (2.5 mm)
Width of groove up to	.079" (2.0 mm)

for use with Insert

Type 105
U105

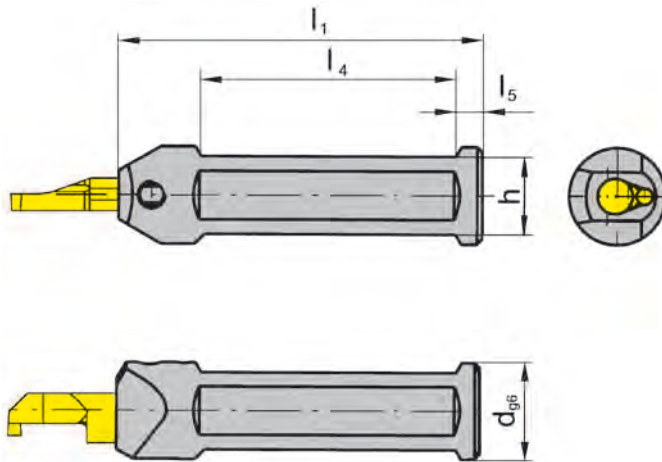

Picture = right hand cutting version shown

Part number	d	l ₁	h	l ₄	l ₅
B105.0022.1.2.01	22	120	20	72	5

Further sizes upon request

Dimensions in mm

Ordering note:

Toolholders can be used with right and left hand inserts.

Spare parts

Toolholder	Screw	TORX PLUS® Wrench
B105.0022.1.2.01	6.075T15P	T15PQ

TOOLHOLDER Type

B105

with through coolant supply

Bore Ø from	.008" (0.2 mm)
Depth of groove up to	.098" (2.5 mm)
Width of groove up to	.079" (2.0 mm)

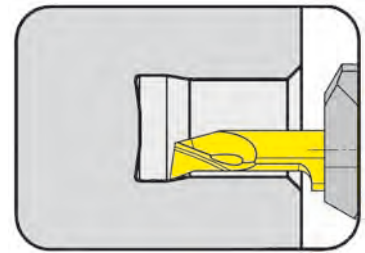

for use with Insert

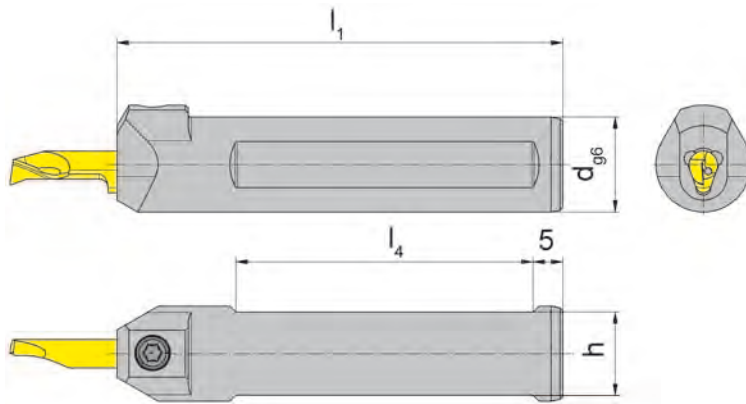
Type 105
U105

Picture = right hand cutting version shown

with additional through
coolant bores

Part number	d	l ₁	h	l ₄
B105.0012.K.01	12	75	11	50
B105.0016.K.01	16	75	14	50
B105.0020.K.01	20	90	18	50

Further sizes upon request

Dimensions in mm

Ordering note:

Toolholders can be used with right and left hand inserts.

Spare parts

Toolholder	Screw	TORX PLUS® Wrench
B105.00...	6.075T15P	T15PQ

TOOLHOLDER Type

B105

with through coolant supply

Bore Ø from	.008" (0.2 mm)
Depth of groove up to	.098" (2.5 mm)
Width of groove up to	.079" (2.0 mm)

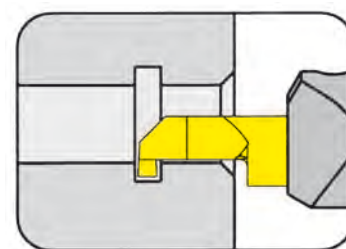

for use with Insert

Type 105
U105

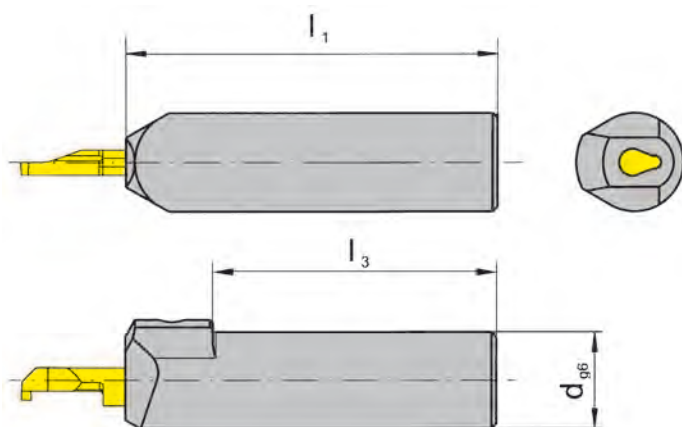

Picture = right hand cutting version shown

Part number	d	l ₁	l ₃
B105.0010.01A	10	75	57
B105.0012.01A	12	75	63
B105.0016.01A	16	75	63

Further sizes upon request

Dimensions in mm

Ordering note:

Toolholders can be used with right and left hand inserts.

Spare parts

Toolholder	Screw	TORX PLUS® Wrench
B105.001...	6.075T15P	T15PQ

TOOLHOLDER Type

B105

with through coolant supply

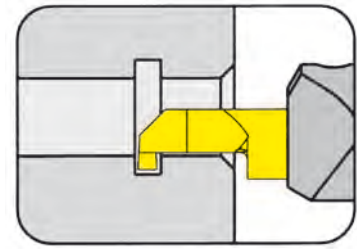

Bore Ø from	.008" (0.2 mm)
Depth of groove up to	.098" (2.5 mm)
Width of groove up to	.079" (2.0 mm)

for use with Insert

Type 105
U105

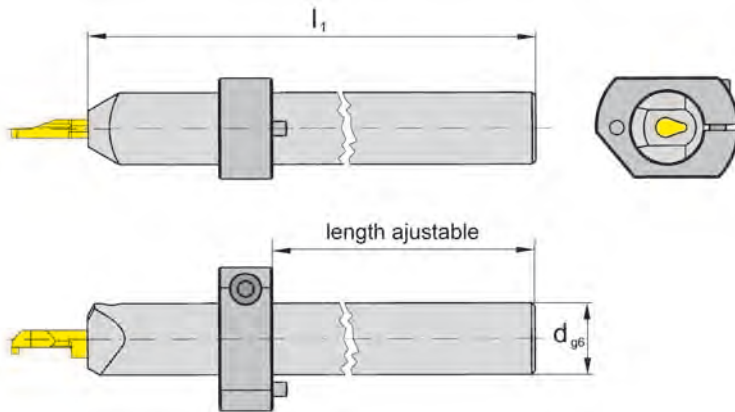

Picture = right hand cutting version shown

Part number	d	l ₁
B105.0020.2.01	20	150
B105.0025.2.01	25	150

Further sizes upon request

Dimensions in mm

Ordering note:

Toolholders can be used with right and left hand inserts.

Adjusting ring is not combined with the toolholder - separate order required!

Adjusting ring

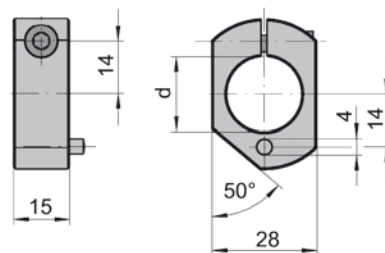

Part number "Adjusting ring"	d	Type of machine
020.0020.1665	20	Tornos DECO
020.0025.2234	25	

TOOLHOLDER Type

B105

with through coolant supply

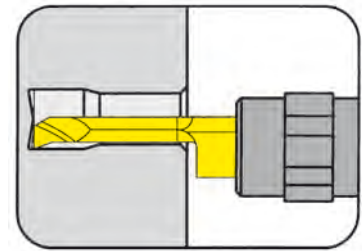

Bore Ø from $\leq .118"$ (3.0mm) or $\geq .197"$ (5.0mm)

for use with Insert

Type 105/U105
 (Ø $\leq .118"$ /3.0mm)
 (Ø $\geq .197"$ /5.0mm)

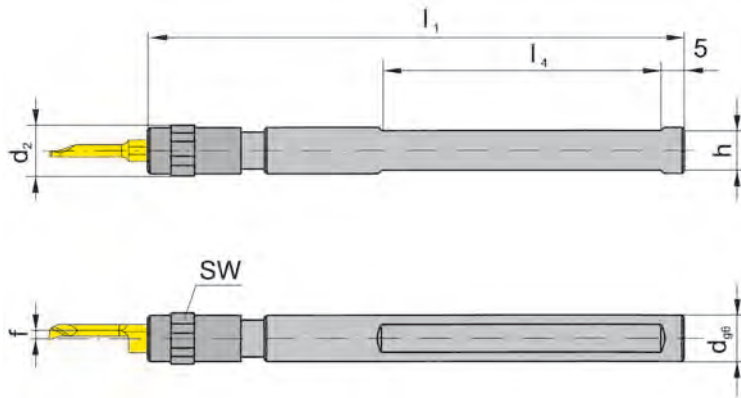

Picture = right hand cutting version shown

Part number	d	l ₁	h	d ₂	l ₄	Bore Range	SW
B105.0010.9.01	10	100	9	11	50	* ≤ 3.0	10
B105.0012.11.01	12		11				
B105.0016.11.01	16	100	15	16	50	* ≥ 5.0	13

Further sizes upon request

f see inserts type 105

Dimensions in mm

* only valid for standard inserts

Ordering note:

Toolholders can be used with right and left hand inserts.

Spare parts

Toolholder	Chucking nut
B105.0010.9.01	020.0010.1719
B105.001...01	020.0016.1999

TOOLHOLDER Type

BU105

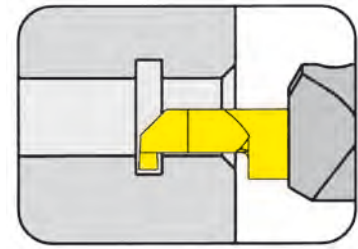

Bore Ø from	.008"
Depth of groove up to	.098"
Width of groove up to	.079"

for use with Insert

Type 105
U105

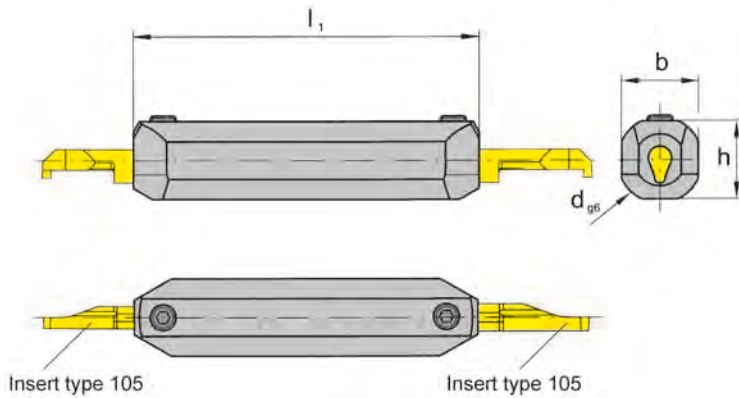

Picture = right and left hand cutting version shown

Part number	d	l ₁	h	b
BU105.0750.2.2.01	.750	4.724	.671	.671

Further sizes upon request

Dimensions in inch

Ordering note:

Toolholders can be used with right and left hand inserts.

Spare parts

Toolholder	Screw	TORX PLUS® Wrench
BU105.0750.2.2.01	6.075T15P	T15PQ

TOOLHOLDER Type

B105

no coolant supply

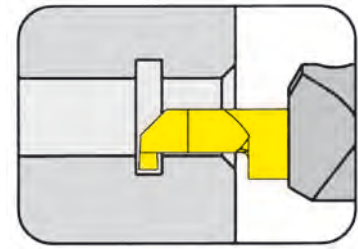

Bore Ø from	.008" (0.2 mm)
Depth of groove up to	.098" (2.5 mm)
Width of groove up to	.079" (2.0 mm)

for use with Insert

Type 105
105...2
U105

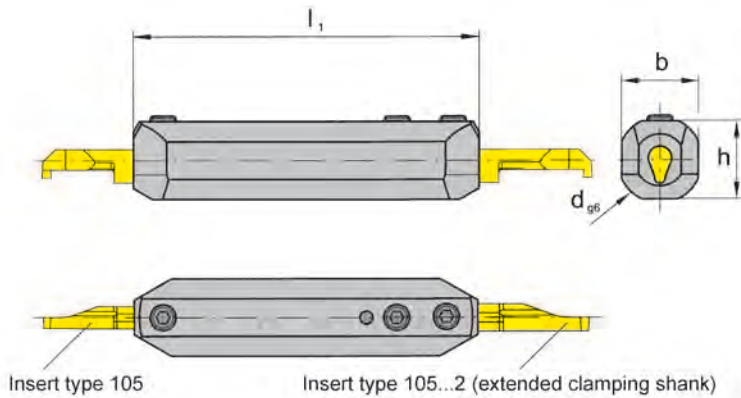

Picture = right and left hand cutting version shown

Part number	d	l ₁	h	b
B105.0020.1.03	20	80	18	18

Further sizes upon request

Dimensions in mm

Ordering note:

Toolholders can be used with right and left hand inserts.

Spare parts

Toolholder	Screw	TORX PLUS® Wrench
B105.0020.1.03	6.075T15P	T15PQ

TOOLHOLDER Type

B105

with through coolant supply

Bore Ø from	.008/.236" (0.2/6.0 mm)
Depth of groove up to	.098/.157" (2.5/4.0 mm)
Width of groove up to	.079/.118" (2.0/3.0 mm)

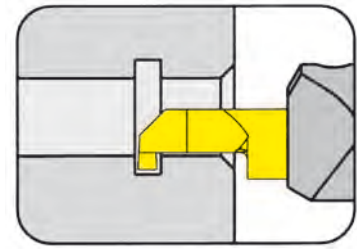

for use with Insert

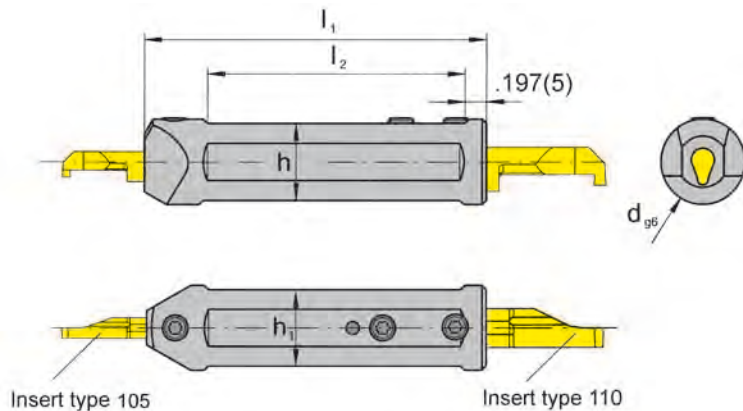
Type 105/U105
110/U110

Picture = right and left hand cutting version shown

Part number	d	l ₁	l ₂	h	h ₁
B105.0020.1.10	20	80	60	18	18

Further sizes upon request

Dimensions in mm

Ordering note:

Toolholders can be used with right and left hand inserts.

Spare parts

Toolholder	Screw	TORX PLUS® Wrench
B105.0020.1.10	6.075T15P	T15PQ

SOLUTIONS PLUS Program

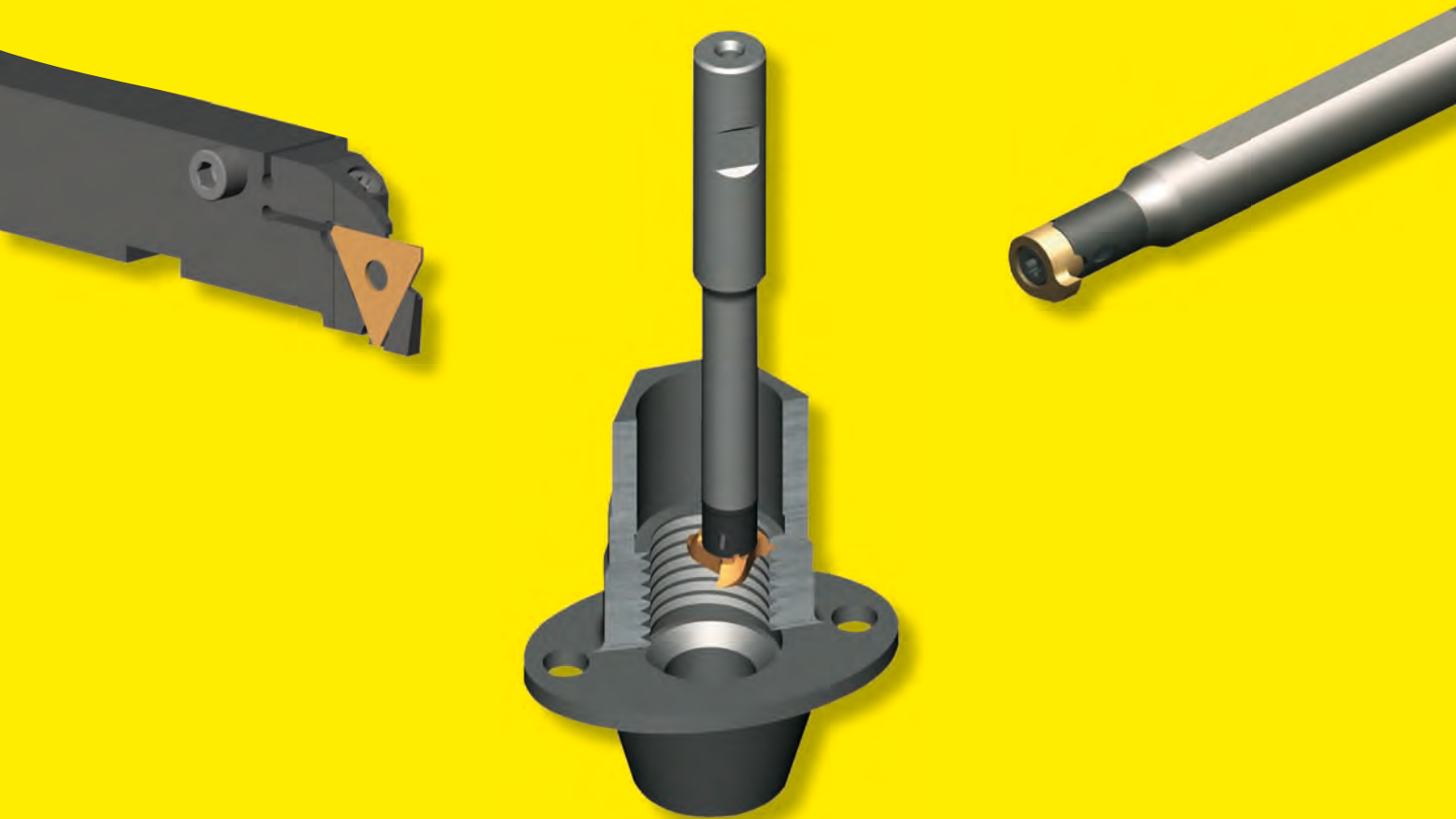

**Need faster delivery?
Inquire about our Solutions Plus Program.**

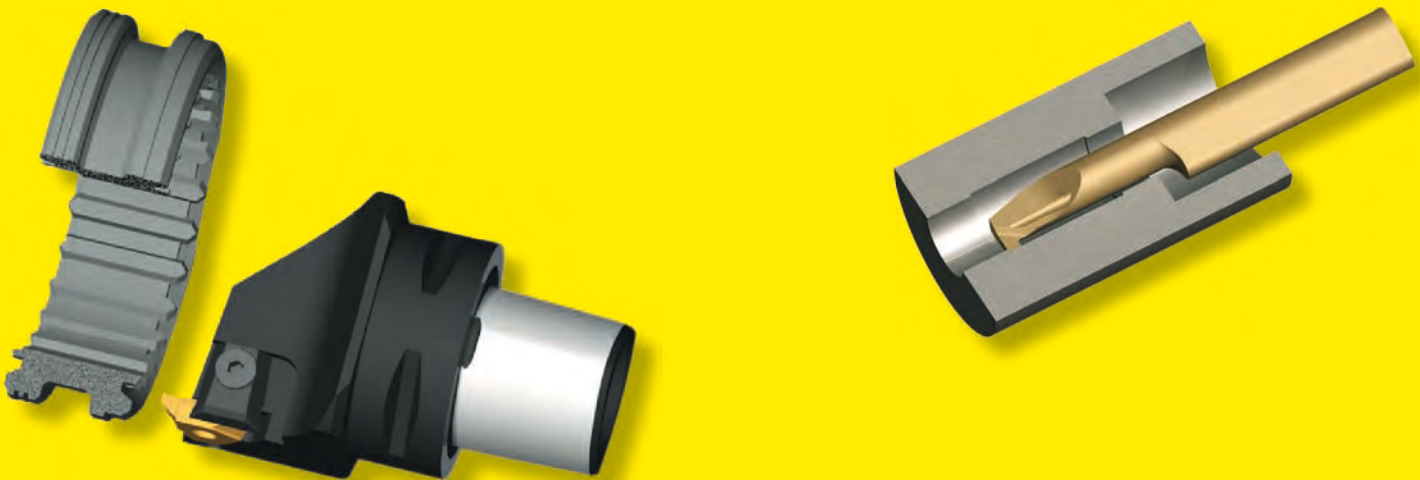

BASIC TOOLHOLDER Type

IR105

with through coolant supply



Bore Ø from

.008" (0.2 mm)

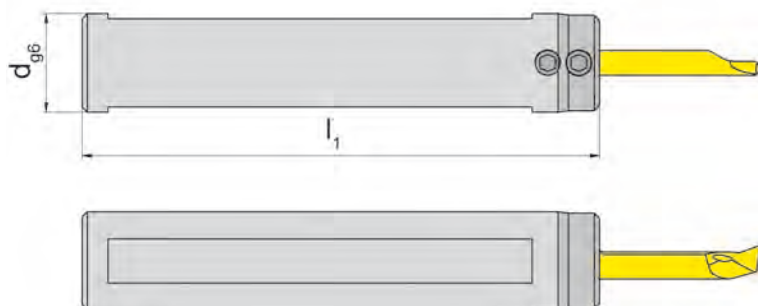

for use with Insert

Type 105
U105

Picture = right hand cutting version shown

Part number	d	l ₁	Type of machine
IR105.34.100	3/4"	100	CITIZEN
IR105.34.40	3/4"	40	
IR105.34.50	3/4"	50	
IR105.34.70	3/4"	70	
IR105.20.30	20,00	30	
IR105.20.50	20,00	50	
IR105.10.100	1"	100	
IR105.10.60	1"	60	STAR
IR105.16.30	16,00	30	
IR105.16.50	16,00	50	
IR105.16.70	16,00	70	
IR105.22.100	22,00	100	
IR105.22.120	22,00	120	
IR105.22.38	22,00	38	
IR105.22.50	22,00	50	TORNOS
IR105.22.70	22,00	70	
IR105.18.310	18,00	310	
IR105.20.170	20,00	170	
IR105.20.185	20,00	185	
IR105.25.100	25,00	100	
IR105.25.150	25,00	150	
IR105.28.80	28,00	80	

Further sizes upon request

Dimensions in mm and inch

Note:

Coolant supply must be ordered separately!

CARTRIDGE Type

IR105

with through coolant supply



Bore Ø from .008" (0.2 mm)

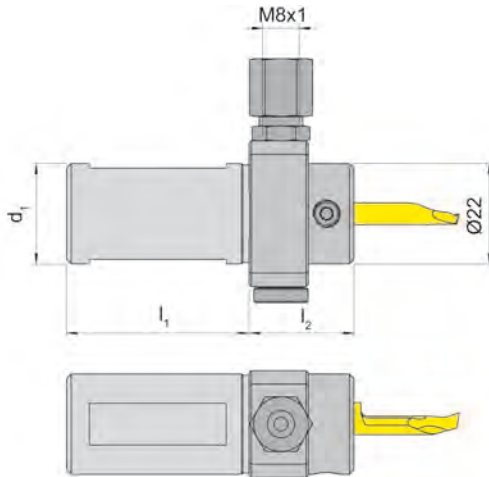

for use with Insert

Type 105
U105



Picture = right hand cutting version shown

Part number	l_1	l_2	d_1
IR105.1640.IKV	40	23	16,00
IR105.3440.IKV	40	23	3/4"
IR105.2040.IKV	40	23	20,00
IR105.2240.IKV	40	23	22,00
IR105.2560.IKV	60	23	25,00
IR105.1060.IKV	60	23	1"

Further sizes upon request

Dimensions in mm and inch

Note:

Coolant supply must be ordered separately!

Spare parts

Cartridge Graf	Screw	TORX PLUS® Wrench
IR105....	6.075T15P	T15PQ

TOOLHOLDER Type

HC105

with screwed clamping

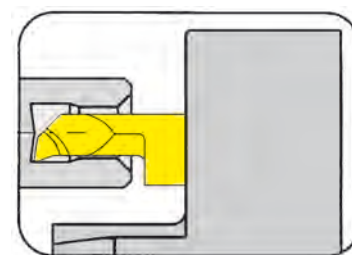

Bore Ø from

.008" (0.2 mm)

Coolant supply through cranked fitting

for use with Insert

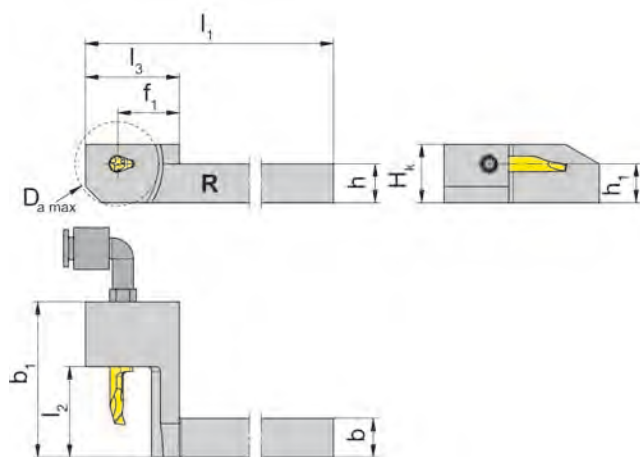
Type 105
U105

L = left hand version shown

R = right hand version

Part number	l_1	l_2	h	h_1	f_1	l_3	b	b_1	$D_{a \max}$	H_k	Remark
R/LHC105.0707.21	99	18	7	7	19	29	7	32.0	26	13	*
R/LHC105.0808.21	99	18	8	8	19	29	8	32.0	26	13	*
RHC105.1010.11	99	8	10	10	19	29	10	22.7	26	16	*
R/LHC105.1010.21	99	18	10	10	19	29	10	38.0	26	16	
R/LHC105.1010.41	99	28	10	10	19	29	10	48.0	26	16	
R/LHC105.1212.21	99	18	12	12	19	29	12	38.0	26	18	
R/LHC105.1212.41	99	28	12	12	19	29	12	48.0	26	18	
R/LHC105.1616.21	104	18	16	16	24	34	16	38.0	36	22	
R/LHC105.1616.41	104	28	16	16	24	34	16	48.0	36	22	

State R or L version

Dimensions in mm

Further sizes upon request

Note:

* = no through coolant supply!

Spare parts

Toolholder	Screw	TORX PLUS® Wrench	Screwed angle fitting
R/LHC105...07./08...	6.075T15P	T15PQ	-
RHC105...11	6.075T15P	T15PQ	-
R/LHC105.1...21/41	6.075T15P	T15PQ	KQ2L06-M5

TOOLHOLDER Type

HC105

with screwed clamping

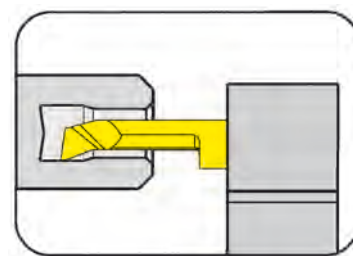

Bore Ø from .008" (0.2 mm)

for use with Insert

Type 105
U105

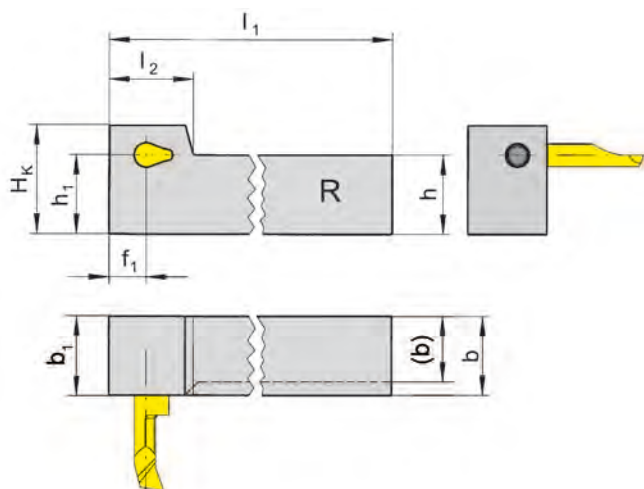

R = right hand version shown

L = left hand version

Part number	l_1	l_2	h	h_1	f_1	b	b_1	H_k
R/LHC105.1212.01	90	17	12	12	7.5	12	16	18
R/LHC105.1616.01	130	17	16	16	7.5	16	16	22

State R or L version

Dimensions in mm

Further sizes upon request

Spare parts

Toolholder	Screw	TORX PLUS® Wrench
R/LHC105.1...	6.075T15P	T15PQ

TOOLHOLDER Type

H105

with screwed clamping

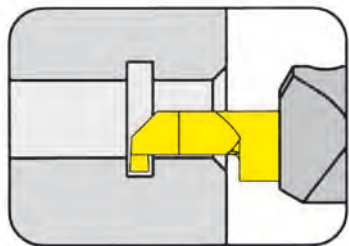

Bore Ø from .008" (0.2 mm)

for use with Insert

Type 105
U105

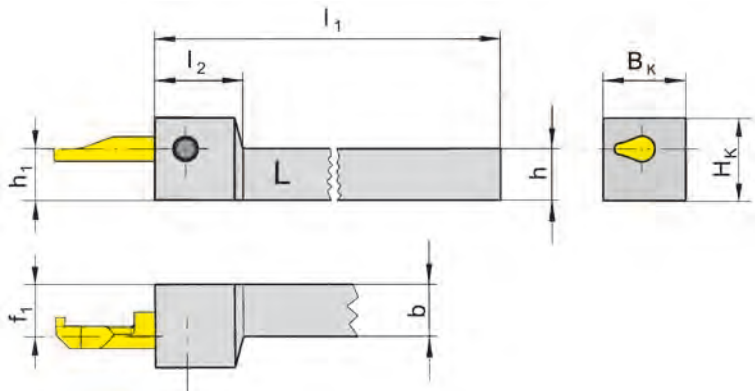

L = left hand version shown

R = right hand version

Part number	l_1	l_2	h	h_1	f_1	b	B_k	H_k
R/LH105.0808.01	90	17	8	8	7.5	8	16	14
R/LH105.1010.01	90	17	10	10	7.5	10	16	16
R/LH105.1212.01	90	17	12	12	7.5	12	16	18
R/LH105.1616.01	110	17	16	16	7.5	16	16	22

State R or L version

Dimensions in mm

Further sizes upon request

Spare parts

Toolholder	Screw	TORX PLUS® Wrench
R/LH105....	6.075T15P	T15PQ

HORN - THE LEADERS IN GROOVING TECHNOLOGY



High Performance Reaming

SYSTEM DR
URMA Licence

Large selection of base material, coatings and geometries.
High repeatability when replacing inserts.
Diameters from 11.9 mm - 140.6 mm.

HORN - INTELLIGENT TOOL DESIGN AT WORK.



For further information, please contact HORN USA.

TOOLHOLDER Type

962

with screwed clamping

Bore Ø from

.008" (0.2 mm)

Coolant through fitting

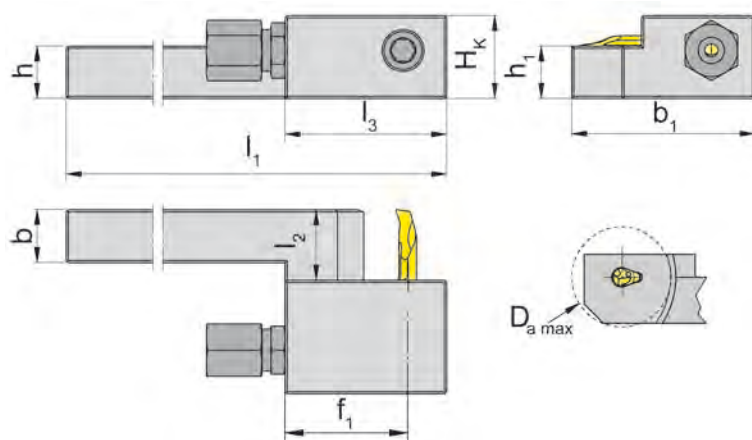

for use with Insert

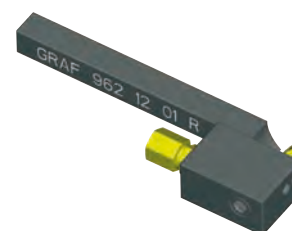
Type 105
U105

R = right hand version shown

L = left hand version

Part number	l_1	l_2	h	h_1	f_1	l_3	b	b_1	$D_{a \max}$	H_k
962.08.01R 962.08.02L	130	15	8	8	27	37	8	42	26	15
962.10.01R 962.10.02L	130	15	10	10	27	37	10	42	26	17
962.12.01R 962.12.02L	130	15	12	12	27	37	12	42	26	19
962.16.01R 962.16.02L	130	15	16	16	27	37	16	42	32	23
962.20.01R 962.20.02L	130	15	20	20	27	37	20	42	32	27

Further sizes upon request

Dimensions in mm

Note:

Coolant supply must be ordered separately!

Spare parts

Toolholder	Screw	TORX PLUS® Wrench	Coolant supply
962....	6.075T15P	T15PQ	004.00.19

TOOLHOLDER Type

962

with screwed clamping



Bore Ø from .008" (0.2 mm)

Coolant through fitting

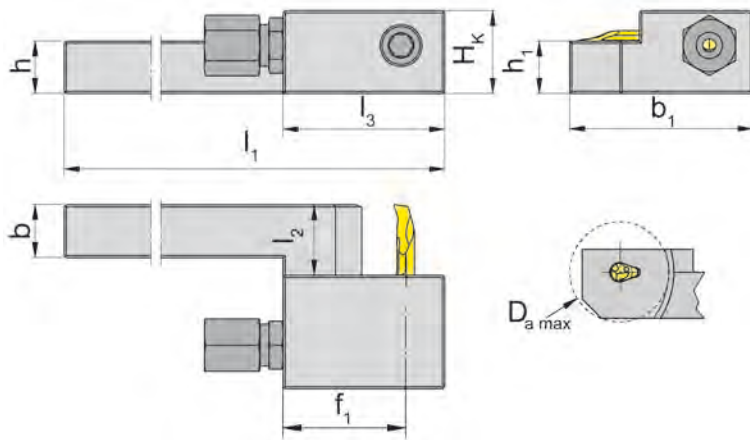

for use with Insert

Type 105
U105

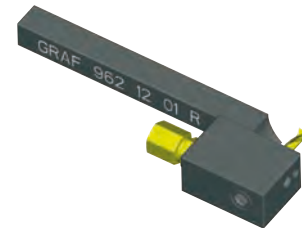

R = right hand version shown

L = left hand version

Part number	l_1	l_2	h	h_1	f_1	l_3	b	b_1	$D_{a \max}$	H_k
962.08.03R 962.08.04L	130	30	8	8	27	37	8	57	26	15
962.10.03R 962.10.04L	130	30	10	10	27	37	10	57	26	17
962.12.03R 962.12.04L	130	30	12	12	27	37	12	57	26	19
962.16.03R 962.16.04L	130	30	16	16	27	37	16	57	32	23
962.20.03R 962.20.04L	130	30	20	20	27	37	20	57	32	27

Further sizes upon request

Dimensions in mm

Note:

Coolant supply must be ordered separately!

Spare parts

Toolholder	Screw	TORX PLUS® Wrench	Coolant supply
962....	6.075T15P	T15PQ	004.00.19

TOOLHOLDER Type

963

with screwed clamping

Bore Ø from .008" (0.2 mm)

Coolant through fitting

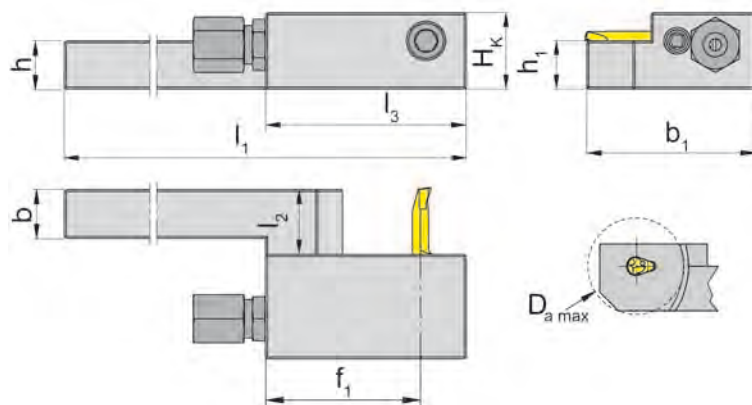

for use with Insert

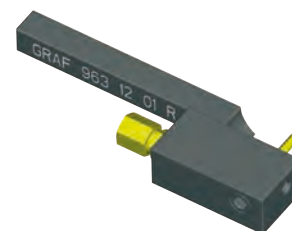
Type 105
U105

R = right hand version shown

L = left hand version

Part number	l_1	l_2	h	h_1	f_1	l_3	b	b_1	$D_{a \max}$	H_k
963.08.01R 963.08.02L	130	15	8	8	40	50	8	42	26	15
963.10.01R 963.10.02L	130	15	10	10	40	50	10	42	26	17
963.12.01R 963.12.02L	130	15	12	12	40	50	12	42	26	19
963.16.01R 963.16.02L	130	15	16	16	45	50	16	42	32	23
963.20.01R 963.20.02L	130	15	20	20	45	50	20	42	32	27

Further sizes upon request

Dimensions in mm

Note:

Coolant supply must be ordered separately!

Spare parts

Toolholder	Screw	TORX PLUS® Wrench	Coolant supply
963....	6.075T15P	T15PQ	004.00.19

TOOLHOLDER Type

AIH



Bore Ø from .008" (0.2 mm)

for use with Insert

Type 105
U105
S274

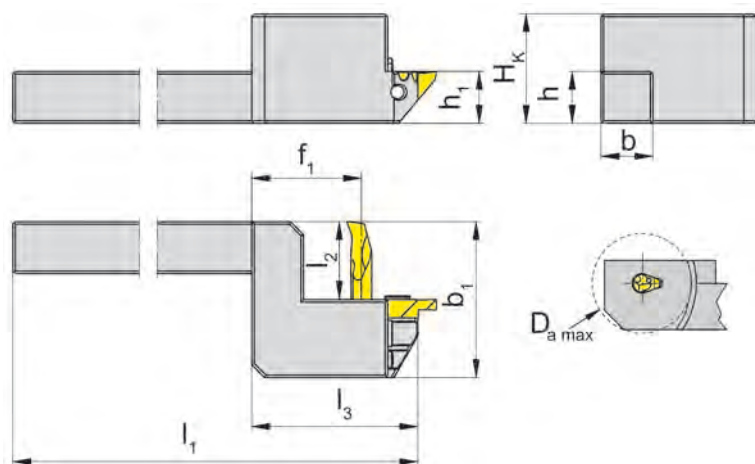

R = right hand version shown

L = left hand version

Part number	l_1	l_2	h	h_1	f_1	l_3	b	b_1	$D_{a \max}$	H_k	Remark
AIH.974.R/L1010.K04			10	10	23	35	10		20	17	
AIH.974.R/L1212.K04	130	15	12	12	23	35	12	30	20	19	*
AIH.974.R/L1616.K04			16	16	26	38	16		26	23	
AIH.974.R/L2020.K04			20	20	29	38	20		32	23	
AIH.R/L1010.K08			10	10	21		10		20	17	
AIH.R/L1212.K08	130	15	12	12	21	30	12	30	20	19	**
AIH.R/L1616.K08			16	16	24		16		26	23	
AIH.R/L2020.K08			20	20	27		20		32	23	

State R or L version

Dimensions in mm

Note:

* These toolholders can be equipped with HORN inserts type 105 and S274

** These toolholders can be equipped with HORN inserts type 105 and Graf inserts CS08

Further sizes upon request

Spare parts

Toolholder	Screw	Screw	TORX PLUS® Wrench
AIH....	030.3509.T15P	6.075T15P	T15PQ

Tools for Tornos DECO2000

for Insert

- Type 105

Bore Ø from .008" (0.2 mm)

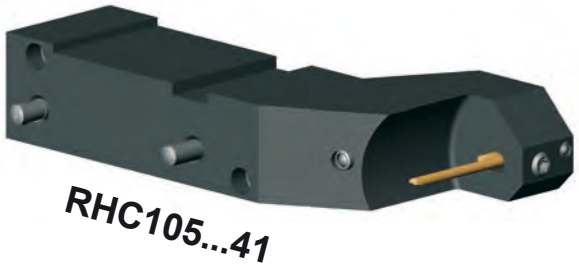

Basic toolholder	Insert	Machine
RHC105.0710.21	105...21 l ₂ up to .591" (15 mm)	DECO7/10
RHC105.0710.41	105...41 l ₂ up to .984" (25 mm)	

Dimensions in inch (mm)

Tools for Tornos DECO2000

for Cassettes

- Type RKC760

Bore Ø from .008" (0.2 mm)

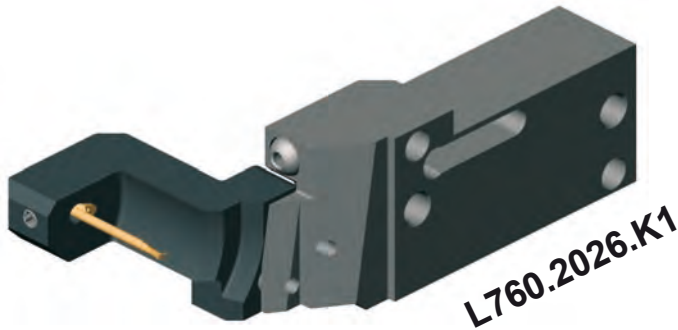
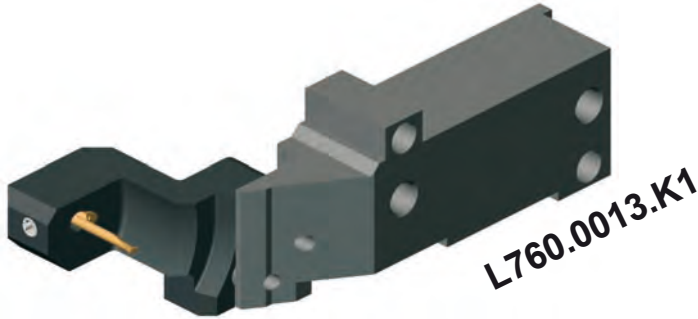

Basic toolholder	Cassette	Insert	Machine
L760.0013.K1	RKC760.0105.21	105...21 l ₂ up to .591" (15 mm)	DECO13
L760.2026.K1	RKC760.0105.41	105...41 l ₂ up to .984" (25 mm)	DECO20/26

Dimensions in inch (mm)

BASIC TOOLHOLDER Type

BGT

without cartridge

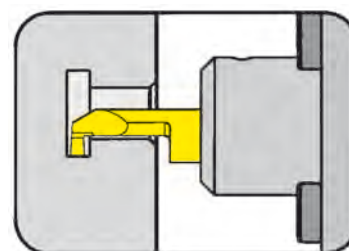

Adjustable round shanks for toolholder BKT105.2445.01/2

with through coolant supply

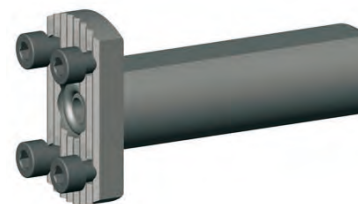
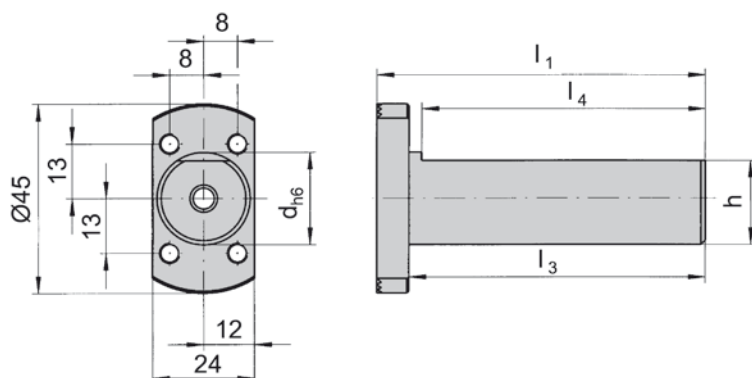

Part number	d	l ₁	h	l ₃	l ₄	Machine tool
BGT001.0010.50	10	57.50	9	50	47	
BGT001.0016.21 BGT001.0R16.21	16	28.50	14	21	18	Star
BGT001.0020.100	20	107.50	18	100	97	Tornos
BGT001.0022.30 BGT001.0022.70	22	36.35 77.50	20	30 70	27 67	Star
BGT001.0025.70	25	77.50	23	70	67	
BGT001.0028.80	28	87.50	26	81	77	Traub

Further sizes upon request

Dimensions in mm

Note:

BGT001.0022.30 without through coolant supply

Spare parts

Basic toolholder	Screw	O-ring
BGT001.0...	DIN912M5X10	DIN37707X3

ADJUSTABLE HOLDER Type **BKT**

Bore Ø from	.008" (0.2 mm)
Depth of groove up to	.098" (2.5 mm)
Width of groove up to	.079" (2.0 mm)

with through coolant supply

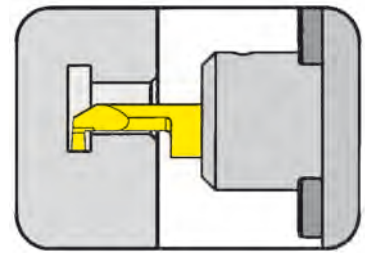

for use with Insert

Type 105
U105

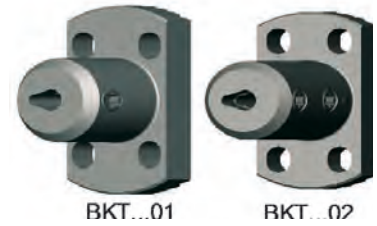
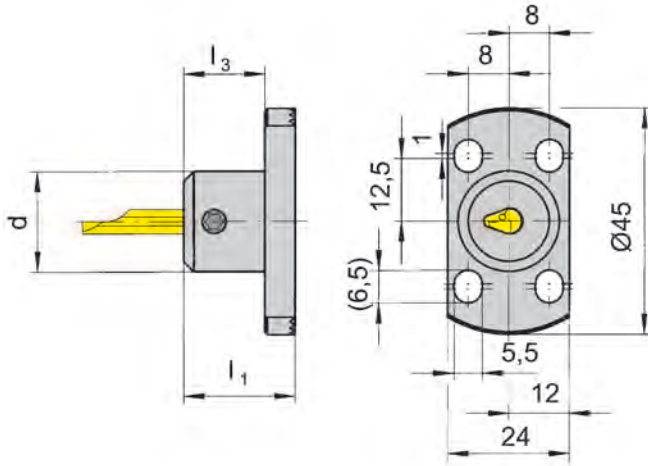

Part number	d	l ₁	l ₃
BKT105.2445.01	20	22	16
BKT105.2445.02		32	26

Further sizes upon request

Dimensions in mm

Spare parts

Adjustable holder	Screw	TORX PLUS® Wrench
BKT105.2445.0...	6.075T15P	T15PQ

BASIC TOOLHOLDER Type

BGT

without cartridge

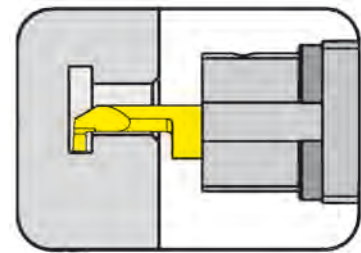

Adjustable round shanks for toolholder BKT105.2327.01

with through coolant supply

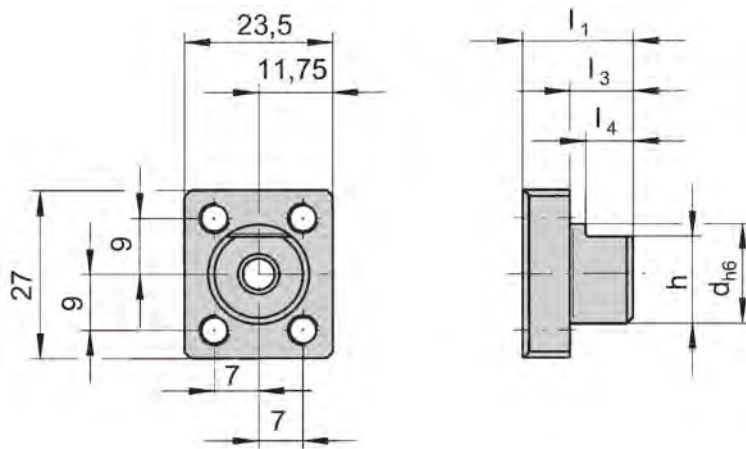

Part number	d	l ₁	h	l ₃	l ₄	Machine tool
BGT001.1627.10	16	17.5	14	10	7.5	Star

Further sizes upon request

Dimensions in mm

Spare parts

Basic toolholder	Screw	O-ring
BGT001.1627.10	DIN912M5X10	DIN37707X3

BASIC TOOLHOLDER Type

BGT

without cartridge

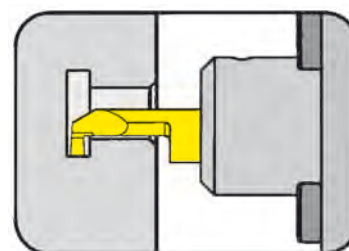

Adjustable round shanks for toolholder BKT105.2327.01

with through coolant supply

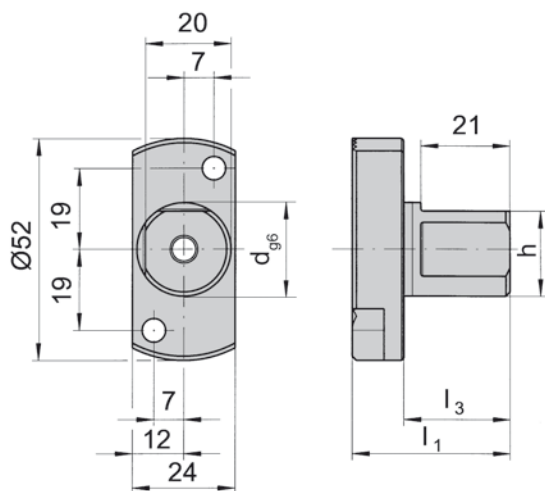

Part number	d	l ₁	h	l ₃
BGT001.0R22.25	22	37	20	25

Further sizes upon request

Dimensions in mm

Spare parts

Basic toolholder	Screw
BGT001.0R22.25	DIN912M5X10

ADJUSTABLE HOLDER Type **BKT**

Bore Ø from	.008" (0.2 mm)
Depth of groove up to	.098" (2.5 mm)
Width of groove up to	.079" (2.0 mm)

with through coolant supply

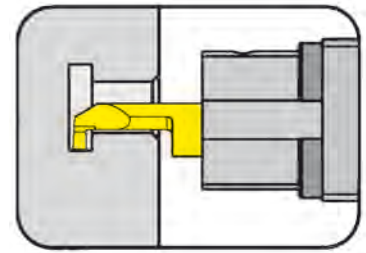

for use with Insert

Type 105
U105

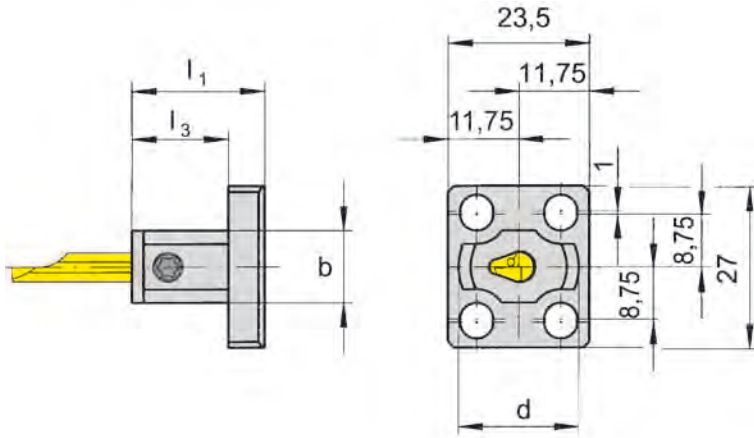

BKT105.2327.01

Part number	d	l ₁	l ₃	b
BKT105.2327.01	20	22	16	12

Further sizes upon request

Dimensions in mm

Spare parts

Adjustable holder	Screw	TORX PLUS® Wrench
BKT105.2327.01	6.075T15P	T15PQ

TOOLHOLDER Type

B105

with through coolant supply

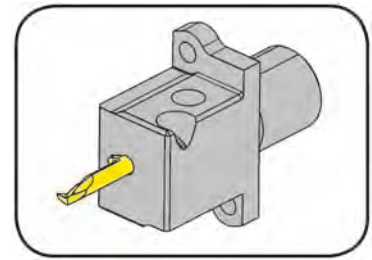

Bore Ø from	.008" (0.2 mm)
Depth of groove up to	.098" (2.5 mm)
Width of groove up to	.079" (2.0 mm)

Through coolant supply G1/8"

for use with Insert

Type 105
U105

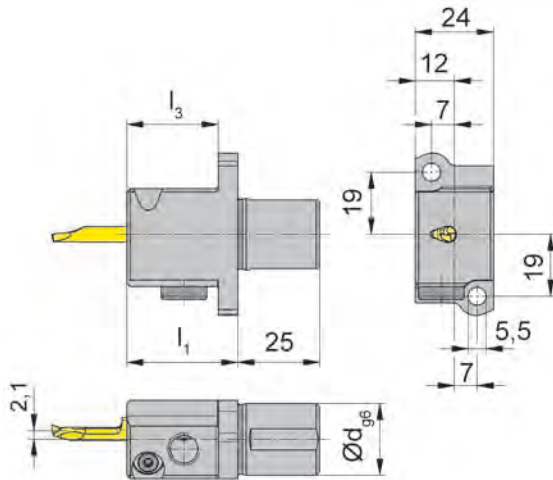

L = left hand version

Star SV 12/20/32
SR 10/20/32 and SB 16

Part number	d	l ₁	l ₃
LB105.A022.26.31	22	34	28

Further sizes upon request

Dimensions in mm

Spare parts

Toolholder	Screw	TORX PLUS® Wrench
LB105.A022.26.31	6.075T15P	T15PQ

BASIC TOOLHOLDER Type

G

without cartridge

for adjustable holder Graf type N and HORN
BKT105.2445.01/2

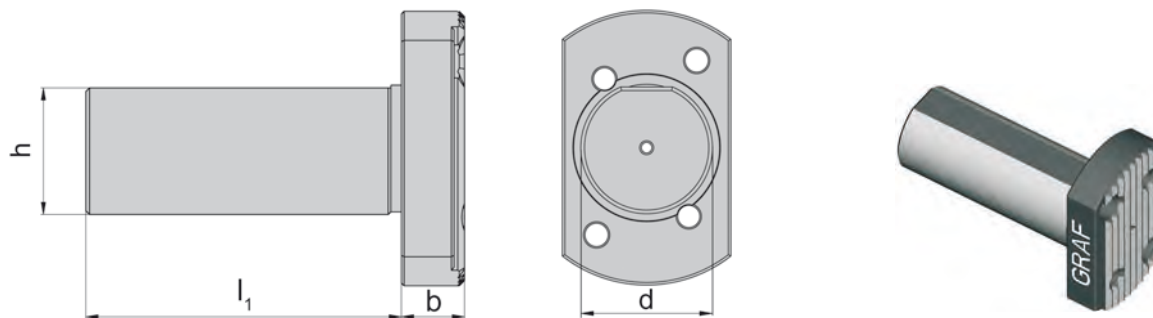

Part number	d	l ₁	h	b	Machine tool
G016021 G016040	16,00	21 40	14	6	Star Traub/Manurhin
G034040 G034050 G034120	3/4"	40 50 120	18	6	Citizen
G020030 G020040 G020100 G020150	20,00	30 40 100 150	18	6	Citizen Hanwha Tornos Manurhin/Tornos
G022023 G022025SR16/20R G022030 G022030SR32 G022070	22,00	23 25 30 30 70	20	6 12 6 12 6	Star

Further sizes upon request

Dimensions in mm and inch

BASIC TOOLHOLDER Type

G

without cartridge



for adjustable holder Graf type N and HORN
BKT105.2445.01/2

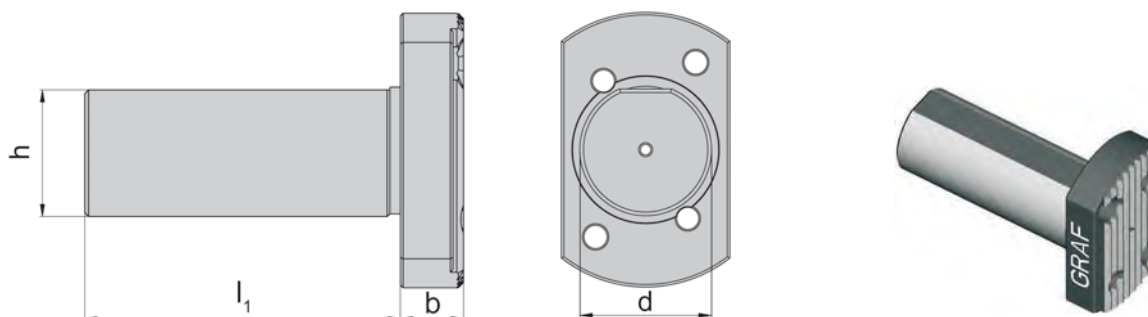

Part number	d	l ₁	h	b	Machine tool
G025060	25,0	60	23	12	Hanwha
G025070		70		6	Manurhin/Tornos
G025100		100		6	Manurhin/Tornos
G025160		160		6	Manurhin/Tornos
G010060	1"	60	23	6	Citizen
G010100		100			
G028006	28,0	6	26	12	Hanwha
G028080		80			Traub
G030045	30,0	45	27	12	Maier
G033040	33,0	40	31	12	Hanwha
G034020	34,0	20	32	12	Maier
G034044		44			Maier/Hanwha

Further sizes upon request

Dimensions in mm and inch

ADAPTOR Type

Z

without cartridge



for adjustable holder Graf type N and HORN
BKT105.2445.01/2

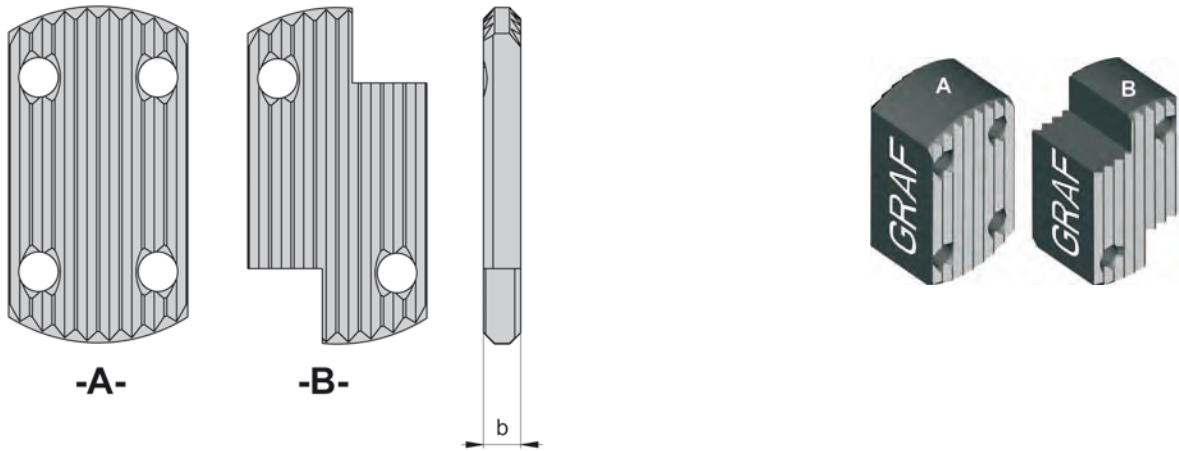

Part number	b	Form
Z5	5	A
Z10	10	
Z15	15	
Z20	20	
Z25	25	
Z30	30	
Z5SR16/20R	5	B
Z10SR16/20R	10	
Z15SR16/20R	15	
Z20SR16/20R	20	
Z25SR16/20R	25	
Z30SR16/20R	30	

Further sizes upon request

Dimensions in mm

ADAPTOR Type

Z

without cartridge



for adjustable holder HORN BKT.105.2327.01

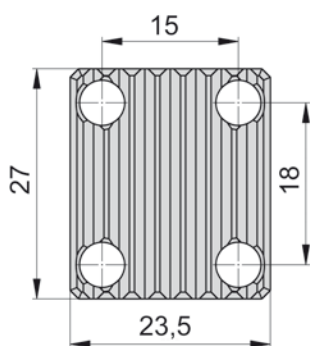

Part number	b
Z10SW7	10
Z15SW7	15
Z20SW7	20
Z25SW7	25
Z30SW7	30

Further sizes upon request

Dimensions in mm

ADAPTOR Type

N

without Cartridge



for adjustable holder Graf type N and HORN BKT105.2445.01/2

for back working

Part number N11

For alternatively 2 cartridges

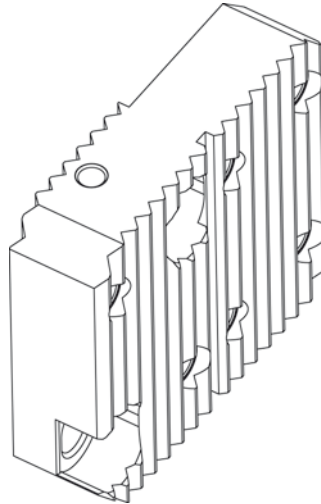
**Part number N12**

For alternatively 3 cartridges

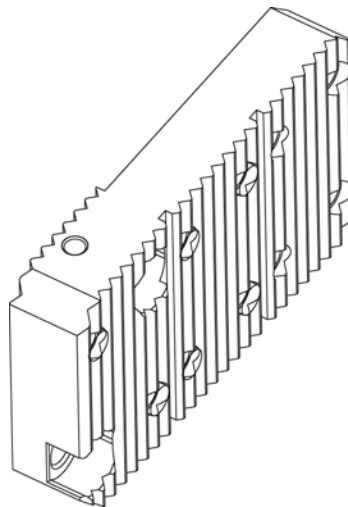
**Part number N93IK**

with through coolant supply

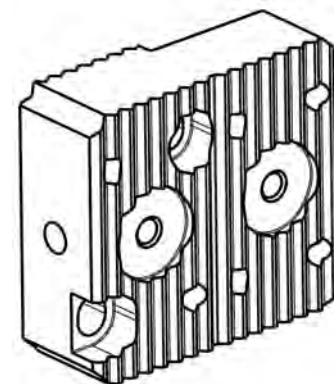

DEVICE FOR HEIGHT ADJUSTING Type **HVR40**



for back working holder HVR40

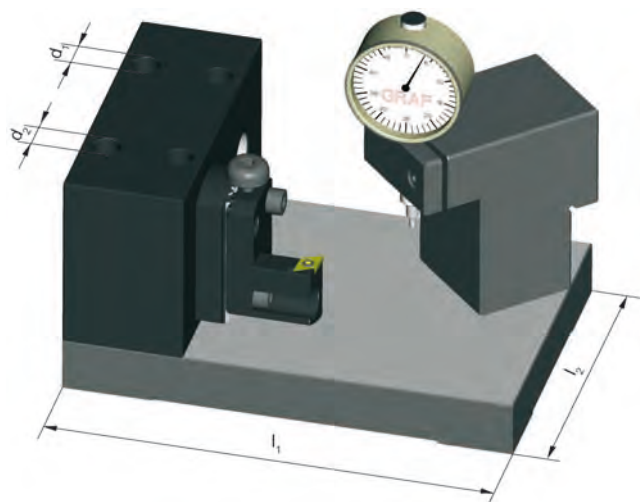

Part number	d ₁	d ₂	l ₁	l ₂	System
12.0506	16	22	250	180	STAR
12.0507	3/4"	1"			CITIZEN
12.0508	30	34			MAIER
12.0511	25	33			HANWHA
12.0523	20	28			HANWHA

Dimensions in mm and inch

ADJUSTABLE HOLDER Type **N**



Bore Ø from	.008" (0.2 mm)
Depth of groove up to	.098" (2.5 mm)
Width of groove up to	.079" (2.0 mm)

with through coolant supply

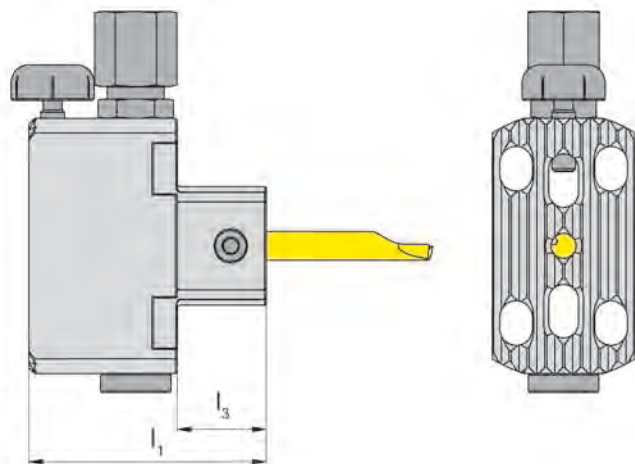

for use with Insert

Type 105
U105



Picture = right hand cutting version shown

Part number	l_1	l_3
N09IK	40	15

Further sizes upon request

Dimensions in mm

Spare parts

Adjustable holder	Screw	Height adjustment screw	Coolant supply
N09IK	6.075T15P	002.00.69	004.00.19

ADJUSTABLE HOLDER Type **N**



Bore Ø from	.008" (0.2 mm)
Depth of groove up to	.098" (2.5 mm)
Width of groove up to	.079" (2.0 mm)

no through coolant supply

for use with Insert

Type 105
U105

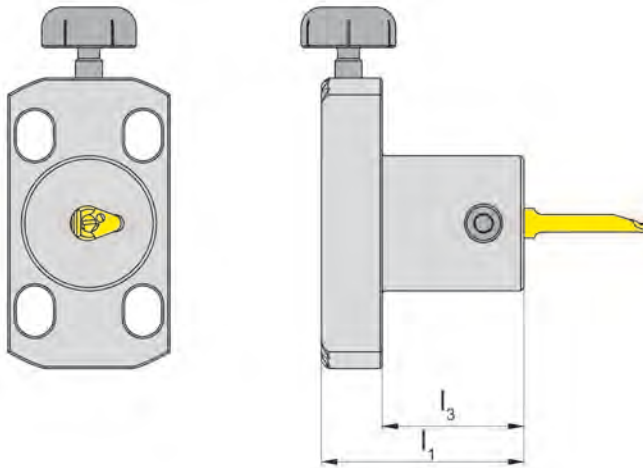

Picture = right hand cutting version shown

Part number	l_1	l_3
N09	30	20

Further sizes upon request

Dimensions in mm

Spare parts

Adjustable holder	Screw	Height adjustment screw
N09	6.075T15P	002.00.69

ADJUSTABLE HOLDER Type **N**



Bore Ø from	.008" (0.2 mm)
Depth of groove up to	.098" (2.5 mm)
Width of groove up to	.079" (2.0 mm)

with through coolant supply

for use with Insert

Type 105
U105

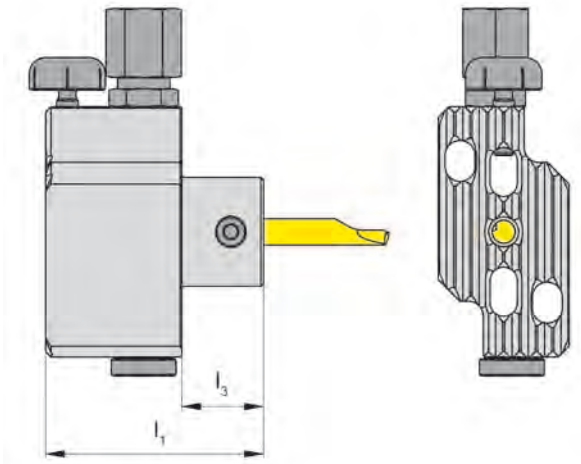

Picture = right hand cutting version shown

Part number	l_1	l_3
N73IK	40	15

Further sizes upon request

Dimensions in mm

Spare parts

Adjustable holder	Screw	Height adjustment screw	Coolant supply
N73IK	6.075T15P	002.00.69	004.00.19

ADJUSTABLE HOLDER Type **N**



Bore Ø from	.008" (0.2 mm)
Depth of groove up to	.098" (2.5 mm)
Width of groove up to	.079" (2.0 mm)

no through coolant supply

for use with Insert

Type 105
U105

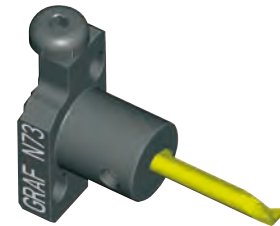
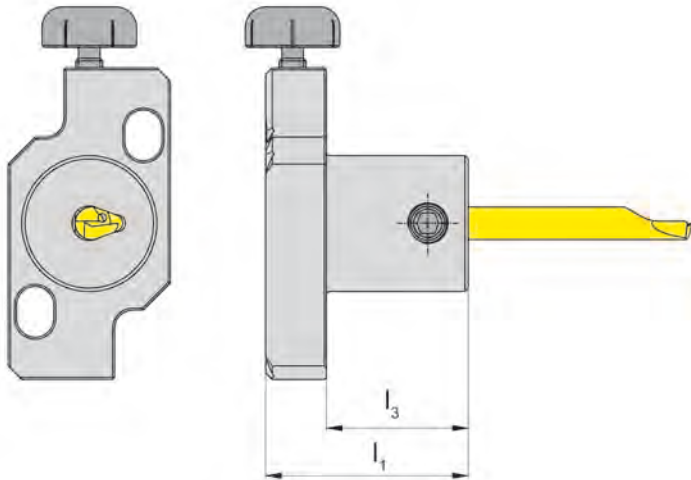

Picture = right hand cutting version shown

Part number	l_1	l_3
N73	30	20

Further sizes upon request

Dimensions in mm

Spare parts

Adjustable holder	Screw	Height adjustment screw
N73	6.075T15P	002.00.69

Standard connection for through cooling

for pipe Ø 6 mm

Connection for through cooling
004.00.19

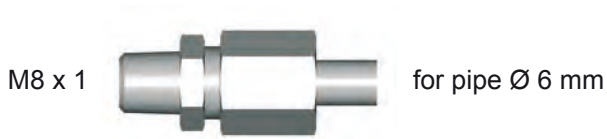

Connection for through cooling
004.00.22

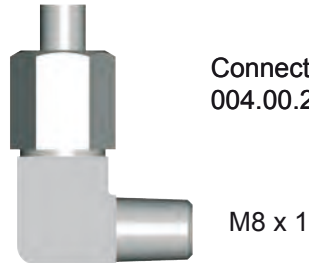

Clip connection for through cooling

M10 x 1

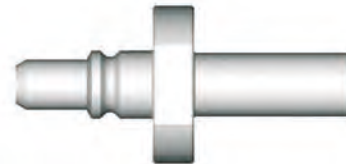
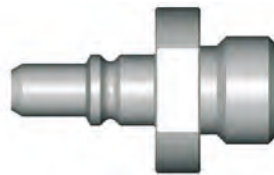

for pipe Ø 6 mm

Coupling

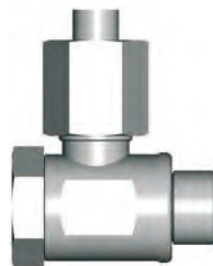

Polygon cutter

For use on lathes with ability to machine polygon profiles

For further information, please see HORN catalog "CARBIDE MILLING TOOLS".

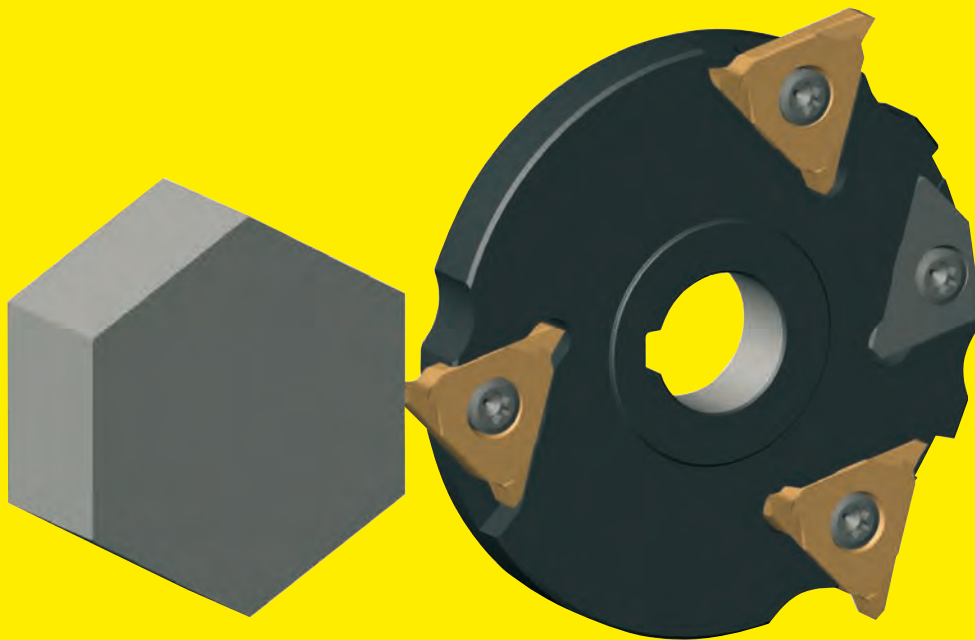

TOOLHOLDER Type

VDI

with through coolant supply

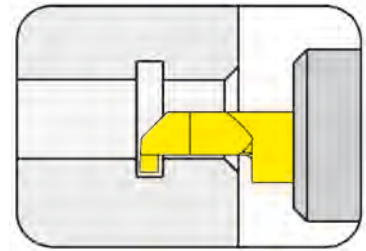

Bore Ø from .008" (0.2 mm)

for use with Insert

Type 105
U105

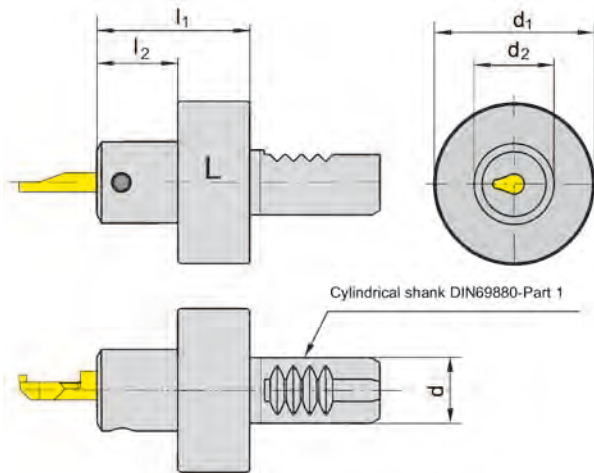

L = left hand version shown

R = right hand version

Part number	d	l ₁	l ₂	d ₂	d ₁
VDI16.R/L105.20.01	16	38	20	20	40
VDI20.R/L105.20.01	20	38	20	20	50
VDI25.R/L105.20.01	25	38	20	20	58
VDI30.R/L105.20.01	30	38	20	20	68
VDI40.R/L105.20.01	40	38	20	20	83

State R or L version

Dimensions in mm

Further sizes upon request

Spare parts

Toolholder	Screw	TORX PLUS® Wrench
VDI...	6.075T15P	T15PQ

TOOLHOLDER Type

B105C

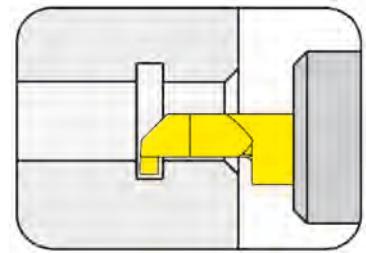

Adapter for inserts type 105 HORN-Capto

for use with Insert

Type 105
U105

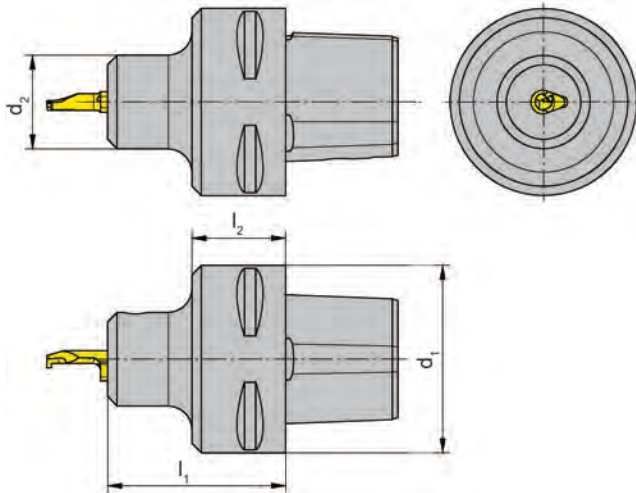

R = right hand version shown

L = left hand version

Licence Sandvik

Part number	l_1	l_2	d_2	d_1	Remark
R/LB105.00C3.20.1.01	30	15	20	32	C3
R/LB105.00C4.20.1.01	38	20		40	C4
R/LB105.00C5.20.1.01	38	20		50	C5
R/LB105.00C6.20.1.01	42	22		63	C6

State R or L version

Dimensions in mm

Further sizes upon request

Spare parts

Toolholder	Screw	TORX PLUS® Wrench
R/LB105.00C...	6.075T15P	T15PQ

TOOLHOLDER Type

B105C

Adapter for inserts type 105 HORN-Capto

for INDEX Multi spindle machines

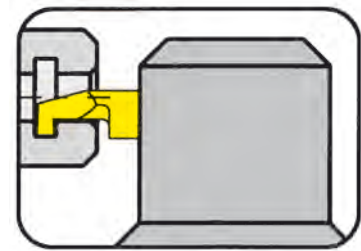

for use with Insert

Type 105
U105

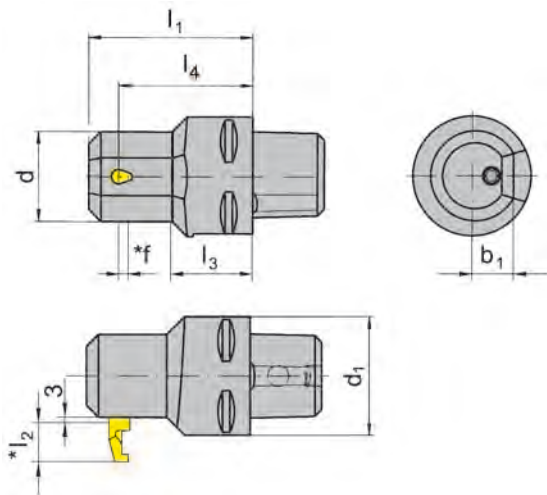

Picture = right hand cutting version shown

Licence Sandvik

Part number	d	l ₁	l ₃	b ₁	l ₄	d ₁	Type of machine
RB105.00C3.2.2.01	30	55	17	14	45	32	MS32
RB105.00C3.2.2.02	36		15	18			
RB105.00C4.2.2.01	30	55	26	14	45	40	MS52
RB105.00C4.2.2.02	36		22	18			

Further sizes upon request

f, l₂ see inserts type 105

Dimensions in mm

Spare parts

Toolholder	Screw	TORX PLUS® Wrench
RB105.00C...	6.075T15P	T15PQ



Supermini® 105 from Ø .008" (0.2 mm)
MINI 108 from Ø.315" (8.0 mm)
Grooving system 264



External and internal machining
- not only for Swiss Type Machines -

BASIC TOOLHOLDER Type

KM16

Basic toolholder for use with toolholder ...KM16...

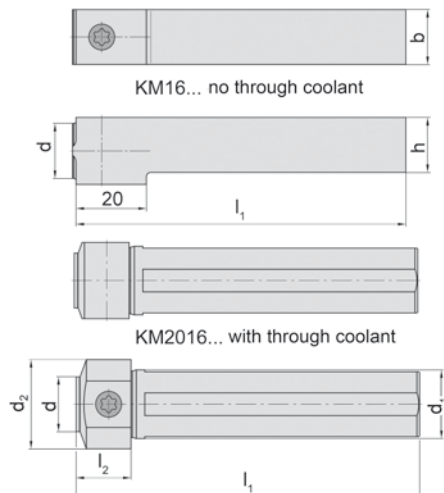
System Kennametal
KM16 Micro

Part number	d	d ₁	d ₂	l ₁	l ₂	h	b
KM16 NCM 1616 100	16	-	-	100	-	16	16
KM2016 NCM SS20 16	20	20	26	100	16	-	-
KM2016 NCM SS22 16	20	22	28	100	16	-	-

Dimensions in mm

Spare parts

Basic toolholder	Screw	TORX PLUS® Blade
KM16 NCM 1616 100 KM2016 NCM SS2...	KM16-NSPKG KM16-NAPKG	DT27PQ DT27PQ

FLANGE Type

KM16



Basic toolholder for use with toolholder ...KM16...

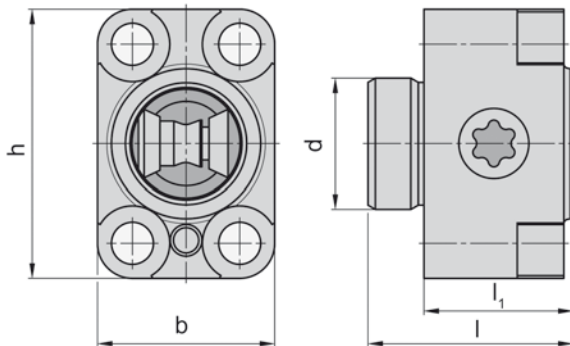

KM16... no through coolant supply

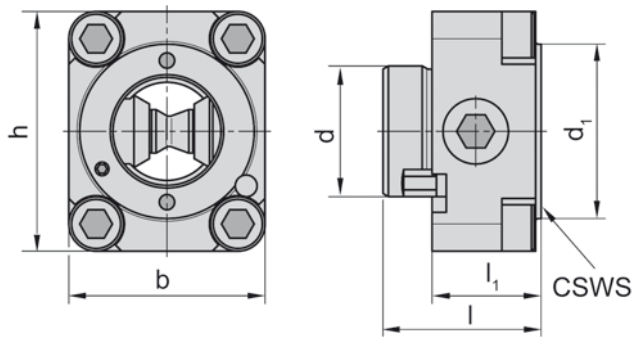

KM2016... with through coolant supply

System Kennametal
KM16 Micro

Part number	l	d	d ₁	l ₁	h	b
KM16NCMSF1928	22	14	-	16	27.5	19
KM2016NCMSF2434	22	20	20	16	33.0	25

Spare parts

Flange	Screw	TORX PLUS® Blade
KM16NCMSF1928 KM2016NCMSF2434	KM16-NSPKG KM16-NAPKG	DT27PQ DT27PQ

TOOLHOLDER Type

B105KM

with through coolant supply

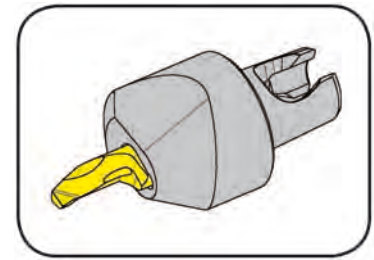

Bore Ø from

.008" (0.2 mm)

for use with Insert

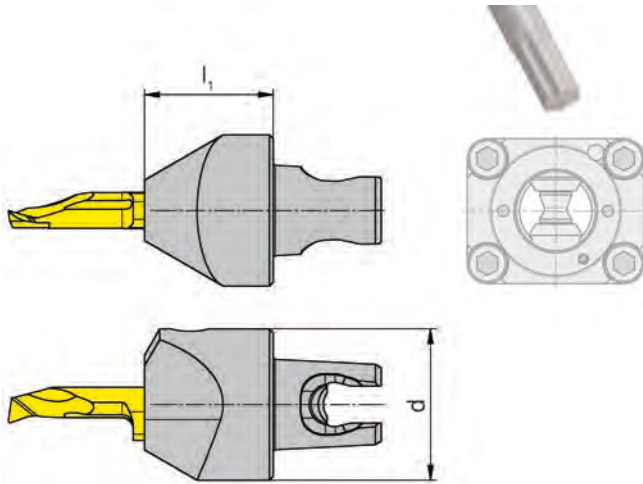
Type 105
U105

Picture = right hand cutting version shown

System Kennametal
KM16 Micro

Part number	d	l ₁
B105.KM16.90.01	20	17

Further sizes upon request

Dimensions in mm

Spare parts

Toolholder	Screw	TORX PLUS® Wrench
B105.KM16.90.01	6.075T15P	T15PQ

TOOLHOLDER Type

B105KM

with through coolant supply

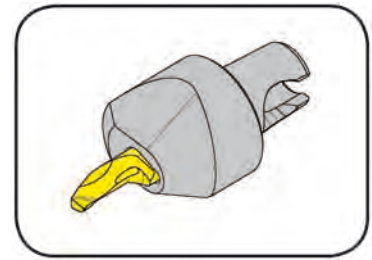

Bore Ø from .008" (0.2 mm)

for use with Insert

Type 105
U105

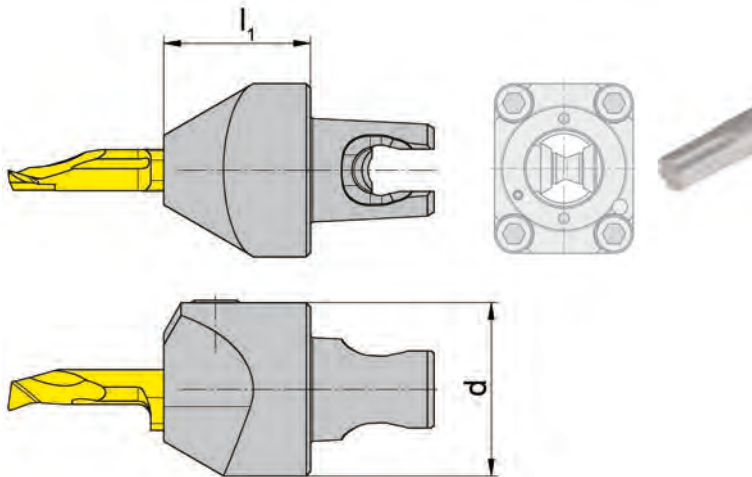

Picture = right hand cutting version shown

System Kennametal
KM16 Micro

Part number	d	l ₁
B105.KM16.01	20	17

Further sizes upon request

Dimensions in mm

Spare parts

Toolholder	Screw	TORX PLUS® Wrench
B105.KM16.01	6.075T15P	T15PQ

TOOLHOLDER Type

B105KM

with through coolant supply

Adapter for inserts type 105 System KM

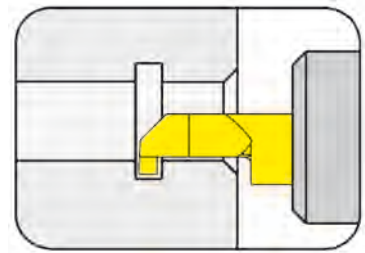

for use with Insert

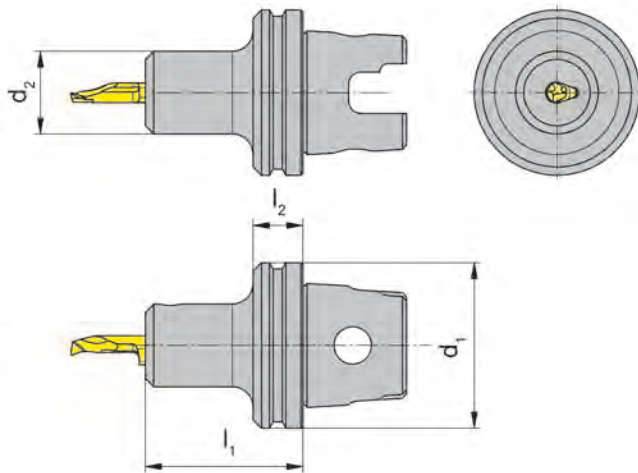
Type 105
U105

R = right hand version shown

L = left hand version

KM-System

Part number	l_1	l_2	d_2	d_1	Remark
R/LB105.KM40.20.1.01	38	12	20	40	KM40

State R or L version

Dimensions in mm

Further sizes upon request

Spare parts

Toolholder	Screw	TORX PLUS® Wrench
R/LB105.KM40.20.1.01	6.075T15P	T15PQ

TOOLHOLDER Type

B105KM

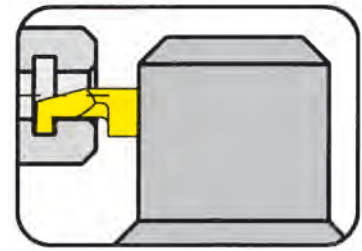

Adapter for inserts type 105 HORN-KM

for INDEX Multi spindle machines

for use with Insert

Type 105
U105

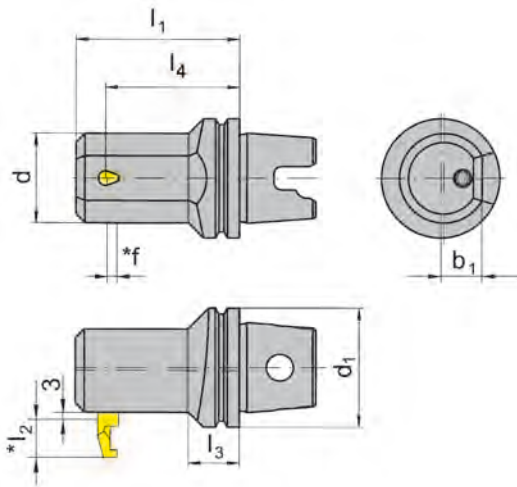

Picture = right hand cutting version shown

Licence Kennametal

Part number	d	l ₁	l ₃	b ₁	l ₄	d ₁	Type of machine
RB105.KM40.2.2.01 RB105.KM40.2.2.02	36	55	17 14	14 18	45	40	MS32
RB105.KM50.2.2.01 RB105.KM50.2.2.02	36	55	26 22	14 18	45	50	MS52

Further sizes upon request

f, l₂ see inserts type 105

Dimensions in mm

Spare parts

Toolholder	Screw	TORX PLUS® Wrench
RB105.KM...	6.075T15P	T15PQ

INSERT Type

105

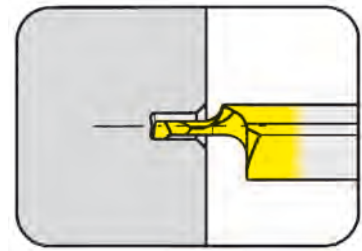

Bore Ø from .008"

for use with Toolholder

- Type BU105
 B105
 B105C
 B105KM
 BKT
 H105
 HC105
 VDI

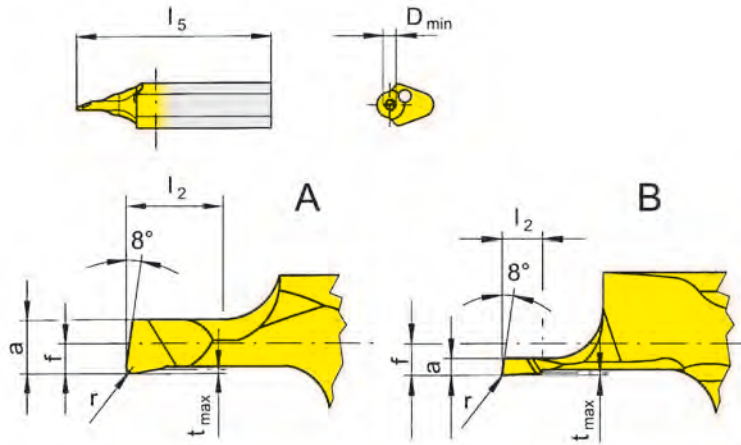

R = right hand version shown

L = left hand version

Part number	f	a	l ₂	l ₅	t _{max}	D _{min}	r	Form	Carbide grades				
									MG12	TN35	TI25	TF45	TH35
R/L105.1802.0.02	.039	.007	.039	.906	.001	.008	.001	B	▲/▲				
R/L105.1802.0.03	.039	.010	.039	.906	.001	.012	.001	B	▲/▲				
R/L105.1802.0.05	.039	.016	.079	.906	.002	.020	.002	B	▲/▲				
R/L105.1803.0.07	.012	.024	.079	.906	.002	.028	.002	A	▲/▲				
									P	○			
									M	•			
									K	•			
									S	•			
									N	•			
									H	•			

- ▲ on stock Δ 4 weeks
- main recommendation
- alternative recommendation
- uncoated grades
- coated grades
- brazed/Cermet

Dimensions in inch

State R or L version

INSERT Type

105

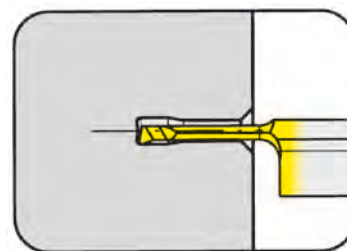

Bore Ø from .039''

for use with Toolholder

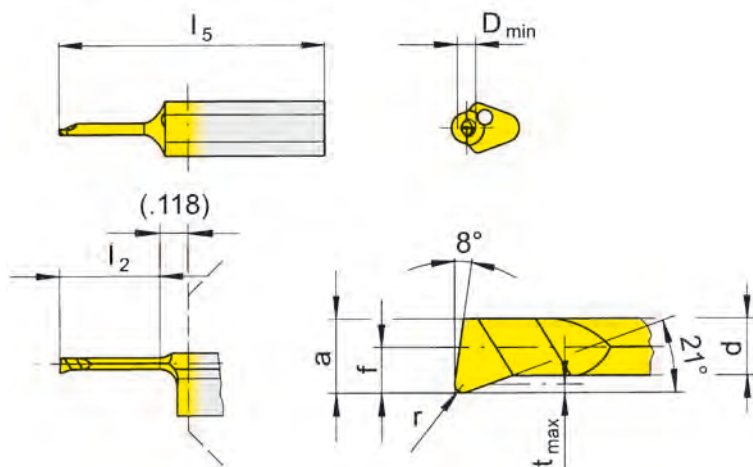

- Type
- BU105
 - B105
 - B105C
 - B105KM
 - BKT
 - H105
 - HC105
 - VDI

R = right hand version shown

L = left hand version

Part number	f	a	d	l ₂	l ₅	t _{max}	D _{min}	r	Carbide grades					
									MG12	TN35	TI25	TF45	TH35	
R/L105.1805.005.0.1				.157	.984	.004	.039	.002				▲▲		
R/L105.1805.005.1.1	.020	.035	.026	.236	.984	.004	.039	.002				▲▲		
R/L105.1805.005.2.1				.315								▲▲		
R/L105.1805.0.1				.157	.984	.004	.039	.004	▲/Δ	▲/▲	▲/Δ			
R/L105.1805.1.1	.020	.035	.026	.236	.984	.004	.039	.004		▲/▲	▲/▲			
R/L105.1805.2.1				.315						▲/▲	▲/▲			
R/L105.1813.005.0.15				.236	.984	.006	.059	.002				▲▲		
R/L105.1813.005.1.15	.051	.055	.043	.354	.984	.006	.059	.002				▲▲		
R/L105.1813.005.2.15				.472	1.181							▲▲		
R/L105.1813.01.0.15				.236	.984	.006	.059	.004				▲/▲		▲/▲
R/L105.1813.01.1.15	.051	.055	.043	.354	.984	.006	.059	.004				▲/▲		▲/▲
R/L105.1813.01.2.15				.472	1.181							▲/▲		▲/▲

- ▲ on stock Δ 4 weeks
- main recommendation
- alternative recommendation
- uncoated grades
- coated grades
- brazed/Cermet

Dimensions in inch

State R or L version

P	○	●	●	●	●
M	●	●	●	●	●
K	●	●	●	●	●
S	●	●	●	●	●
N	●	●	●	●	●
H					

Carbide grades

INSERT Type

105

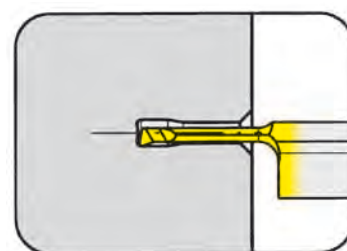

Bore Ø from .079''

for use with Toolholder

- Type BU105
 B105
 B105C
 B105KM
 BKT
 H105
 HC105
 VDI

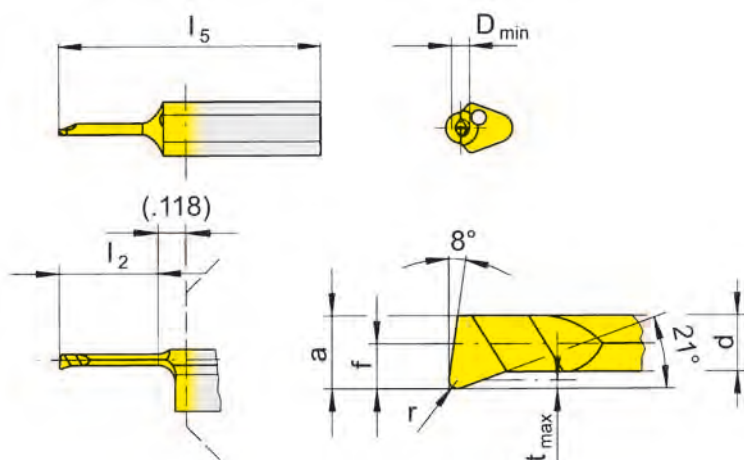

R = right hand version shown

L = left hand version

Part number	f	a	d	l ₂	l ₅	t _{max}	D _{min}	r	Carbide grades					
									MG12	TN35	TI25	TF45	TH35	
R/L105.1809.005.0.2				.236	.984							▲▲		
R/L105.1809.005.1.2	.039	.075	.063	.354	.984	.006	.079	.002				▲▲		
R/L105.1809.005.2.2				.472	1.181							▲▲		
R/L105.1809.01.0.2				.236	.984							▲▲		▲▲
R/L105.1809.01.1.2	.039	.075	.063	.354	.984	.006	.079	.004				▲▲		▲▲
R/L105.1809.01.2.2				.472	1.181							▲▲		▲▲
R/L105.1809.0.2				.236	.984				▲/Δ	▲/▲	▲/▲			▲/▲
R/L105.1809.1.2	.039	.075	.063	.354	.984	.006	.079	.006	▲/Δ	▲/▲	▲/▲			▲/▲
R/L105.1809.2.2				.472	1.181				▲/Δ	▲/▲	▲/▲			▲/▲
R/L105.1813.005.0.25				.236	.984									▲/▲
R/L105.1813.005.1.25				.354	.984									▲▲
R/L105.1813.005.2.25	.051	.091	.077	.472	1.181	.006	.098	.002				▲▲		▲▲
R/L105.1813.005.3.25				.630	1.378							▲/		

- ▲ on stock Δ 4 weeks
- main recommendation
- alternative recommendation
- uncoated grades
- coated grades
- brazed/Cermet

Dimensions in inch
 State R or L version

P	○	●	●	●	●
M	●	●	●	●	●
K	●	●	●	●	●
S	●	●	●	●	●
N	●	●	●	●	●
H					

Carbide grades

INSERT Type

105

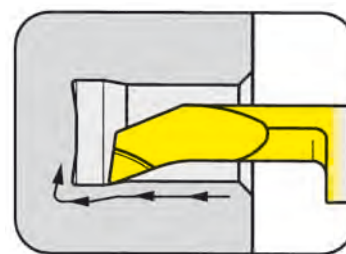

Bore Ø from .118"

for use with Toolholder

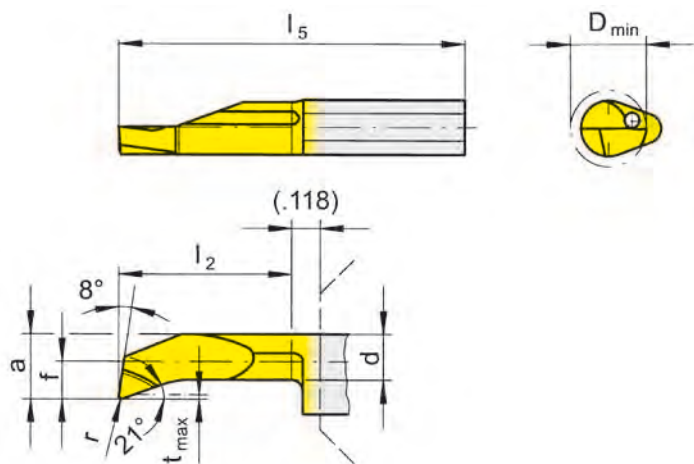

- Type BU105
B105
B105C
B105KM
BKT
H105
HC105
VDI

R = right hand version shown

L = left hand version

Part number	f	a	d	l ₂	l ₅	t _{max}	D _{min}	r	MG12	TN35	TI25	TF45	TH35
R/L105.1813.005.1.3				.394	.984							▲▲	
R/L105.1813.005.2.3	.051	.102	.091	.591	1.181	.006	.118	.002				▲▲	
R/L105.1813.005.3.3				.787	1.378							▲▲	
R/L105.1813.01.1.3				.394	.984						▲▲		▲▲
R/L105.1813.01.2.3	.051	.102	.091	.591	1.181	.006	.118	.004			▲▲		▲▲
R/L105.1813.01.3.3				.787	1.378						▲▲		▲▲
R/L105.1813.1.3				.394	.984				▲/▲	▲/▲	▲/▲		▲/▲
R/L105.1813.2.3	.051	.102	.091	.591	1.181	.006	.118	.008	▲/▲	▲/▲	▲/▲		▲/▲
R/L105.1813.3.3				.787	1.378				▲/▲	▲/▲	▲/▲		▲/▲
R/L105.1819.005.1.4				.394	.984							▲▲	
R/L105.1819.005.2.4	.075	.146	.114	.591	1.181	.012	.157	.002				▲▲	
R/L105.1819.005.3.4				.787	1.378							▲▲	
R/L105.1819.1.4				.394	.984				▲/▲	▲/▲	▲/▲		▲/▲
R/L105.1819.2.4	.075	.146	.114	.591	1.181	.012	.157	.008	▲/▲	▲/▲	▲/▲		▲/▲
R/L105.1819.3.4				.787	1.378				▲/▲	▲/▲	▲/▲		▲/▲

- ▲ on stock Δ 4 weeks
- main recommendation
- alternative recommendation
- uncoated grades
- coated grades
- brazed/Cermet

P	○	●	●	●	●
M	●	●	●	●	●
K	●	●	●	●	●
S	●	●	●	●	●
N	●	●	●	●	●
H					

Carbide grades

Dimensions in inch

State R or L version

INSERT Type

105

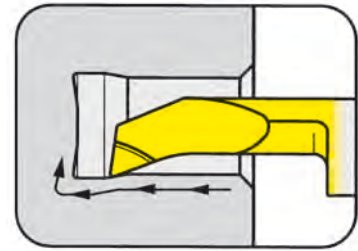

Bore Ø from .197"

for use with Toolholder

- Type BU105
 B105
 B105C
 B105KM
 BKT
 H105
 HC105
 VDI

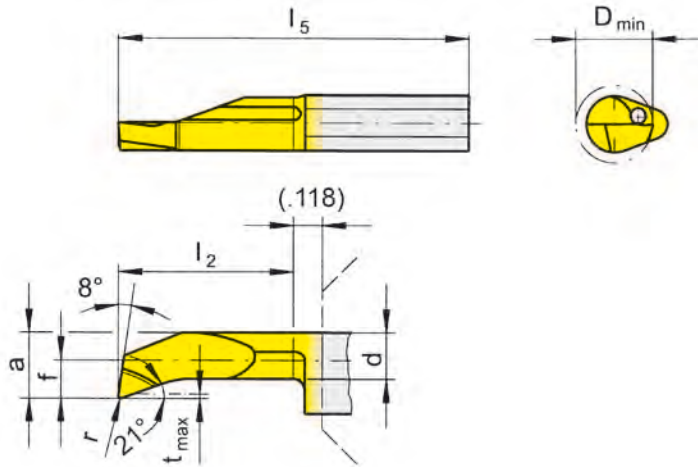

R = right hand version shown

L = left hand version

Part number	f	a	d	l ₂	l ₅	t _{max}	D _{min}	r	Carbide grades					
									MG12	TN35	TI25	TF45	TH35	
R/L105.1823.005.1.5				.394	.984							▲▲		
R/L105.1823.005.2.5				.591	1.181							▲▲		
R/L105.1823.005.3.5	.091	.185	.157	.787	1.378	.020	.197	.002				▲▲		
R/L105.1823.005.4.5				.984	1.575							▲▲		
R/L105.1823.005.5.5				1.181	1.772							▲▲		
R/L105.1823.1.5				.394	.984				▲/▲	▲/▲	▲/▲		▲/▲	
R/L105.1823.2.5				.591	1.181				▲/▲	▲/▲	▲/▲		▲/▲	
R/L105.1823.3.5	.091	.185	.157	.787	1.378	.020	.197	.008	▲/▲	▲/▲	▲/▲		▲/▲	
R/L105.1823.4.5				.984	1.575				▲/▲	▲/▲	▲/▲		▲/▲	
R/L105.1823.5.5				1.181	1.772				▲/▲	▲/▲	▲/▲		▲/▲	
▲ on stock Δ 4 weeks ● main recommendation ○ alternative recommendation □ uncoated grades ■ coated grades ■ brazed/Cermet									P	○	●	●	●	●
									M	●	●	●	●	●
									K	●	●	●	●	●
									S	●	●	●	●	●
									N	●	●	●	●	●
									H	●	●	●	●	●

Dimensions in inch

State R or L version

Carbide grades

INSERT Type

105

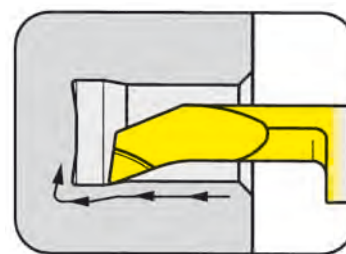

Bore Ø from .236"

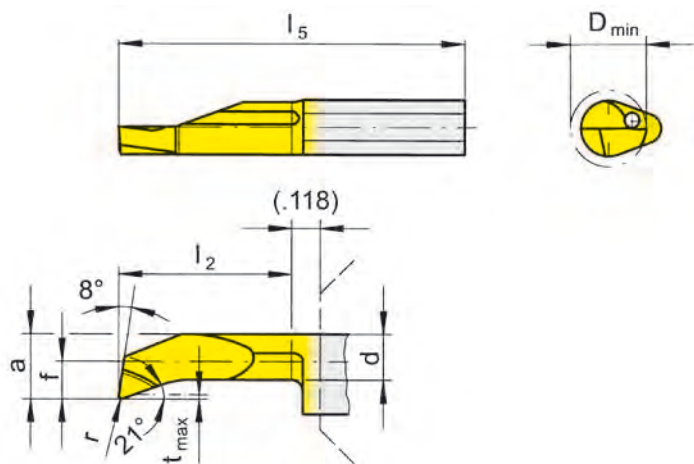

for use with Toolholder

- Type BU105
- B105
- B105C
- B105KM
- BKT
- H105
- HC105
- VDI

R = right hand version shown

L = left hand version

Part number	f	a	d	l ₂	l ₅	t _{max}	D _{min}	r	Carbide grades				
									MG12	TN35	TI25	TF45	TH35
R/L105.1833.005.2.6	.130	.224	.185	.591	1.181	.020	.236	.002				▲▲	
R/L105.1833.005.3.6				.787	1.378				▲▲				
R/L105.1833.005.4.6				.984	1.575				▲▲				
R/L105.1833.005.5.6				1.181	1.772				▲▲				
R/L105.1833.2.6	.130	.224	.185	.591	1.181	.020	.236	.008	▲/▲	▲/▲	▲▲		▲/▲
R/L105.1833.3.6				.787	1.378				▲/▲	▲▲	▲/▲		
R/L105.1833.4.6				.984	1.575				▲/▲	▲▲	▲/▲		
R/L105.1833.5.6				1.181	1.772				▲/▲	▲▲	▲/▲		
R/L105.1840.005.3.7	.157	.252	.205	.787	1.378	.020	.268	.002				▲▲	
R/L105.1840.005.4.7				.984	1.575				▲▲				
R/L105.1840.005.5.7				1.181	1.772				▲▲				
R/L105.1840.3.7	.157	.252	.205	.787	1.378	.020	.268	.008	▲/▲	▲/▲	▲▲		▲/▲
R/L105.1840.4.7				.984	1.575				▲/▲	▲▲	▲/▲		
R/L105.1840.5.7				1.181	1.772				▲/▲	▲▲	▲/▲		

- ▲ on stock Δ 4 weeks
- main recommendation
- alternative recommendation
- uncoated grades
- coated grades
- brazed/Cermet

P	○	●	●	●	●
M	●	●	●	●	●
K	●	●	●	●	●
S	●	●	●	●	●
N	●	●	●	●	●
H					

Dimensions in inch

Carbide grades

State R or L version

INSERT Type

105

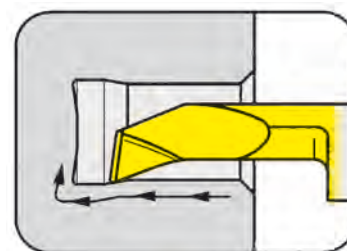

Bore Ø from .157"

for use with Toolholder

- Type BU105
- B105
- B105C
- B105KM
- BKT
- H105
- HC105
- VDI

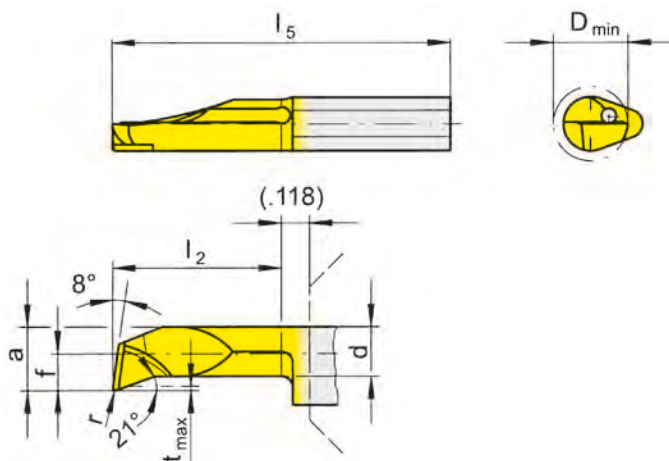

R = right hand version shown

L = left hand version

extended chip breaker
(geometry HV)

Part number	f	a	d	l ₂	l ₅	t _{max}	D _{min}	r	Carbide grades					
									MG12	TN35	TI25	TF45	TH35	
R/L105.1819.1.HV4				.394	.984									▲▲
R/L105.1819.2.HV4	.075	.146	.114	.591	1.181	.012	.157	.008						▲▲
R/L105.1819.3.HV4				.787	1.378									▲▲
R/L105.1823.1.HV5				.394	.984									▲▲
R/L105.1823.2.HV5				.591	1.181									▲▲
R/L105.1823.3.HV5	.091	.185	.157	.787	1.378	.020	.197	.008						▲▲
R/L105.1823.4.HV5				.984	1.575									▲▲
R/L105.1823.5.HV5				1.181	1.772									▲▲
R/L105.1833.2.HV6				.591	1.181									▲▲
R/L105.1833.3.HV6				.787	1.378									▲▲
R/L105.1833.4.HV6	.130	.224	.185	.984	1.575	.020	.236	.008						▲▲
R/L105.1833.5.HV6				1.181	1.772									▲▲
R/L105.1840.3.HV7				.787	1.378									▲▲
R/L105.1840.4.HV7	.157	.252	.205	.984	1.575	.020	.268	.008						▲▲
R/L105.1840.5.HV7				1.181	1.772									▲▲

- ▲ on stock Δ 4 weeks
- main recommendation
- alternative recommendation
- uncoated grades
- coated grades
- brazed/Cermet

	P	M	K	S	N	H
MG12						
TN35						
TI25						
TF45						
TH35	●	●	●	●	●	●

Dimensions in inch

Carbide grades

State R or L version

INSERT Type

105

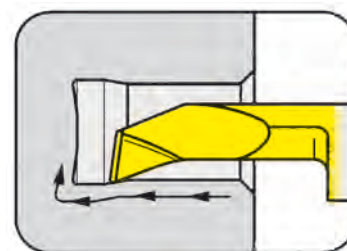

Bore Ø from .157"

for use with Toolholder

- Type BU105
 B105
 B105C
 B105KM
 BKT
 H105
 HC105
 VDI

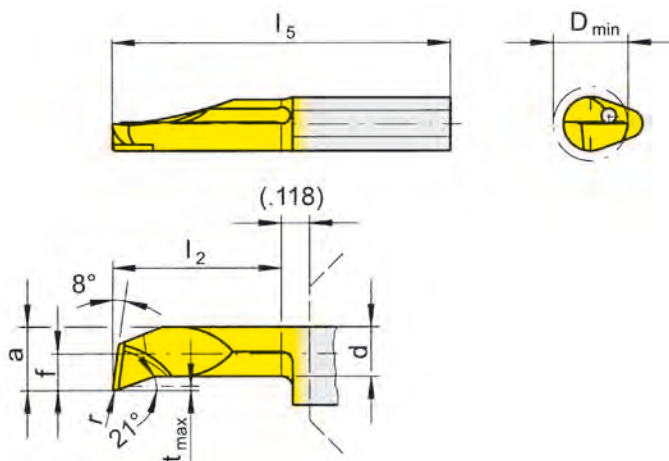

R = right hand version shown

L = left hand version

extended chip breaker
 (geometry HV)

Part number	f	a	d	l ₂	l ₅	t _{max}	D _{min}	r	Carbide grades					
									MG12	TN35	TI25	TF45	TH35	
R/L105.1819.04.1.HV4				.394	.984									▲▲
R/L105.1819.04.2.HV4	.075	.146	.114	.591	1.181	.012	.157	.016						▲▲
R/L105.1819.04.3.HV4				.787	1.378									▲▲
R/L105.1823.04.1.HV5				.394	.984									▲▲
R/L105.1823.04.2.HV5				.591	1.181									▲▲
R/L105.1823.04.3.HV5	.091	.185	.157	.787	1.378	.020	.197	.016						▲▲
R/L105.1823.04.4.HV5				.984	1.575									▲▲
R/L105.1823.04.5.HV5				1.181	1.772									▲▲
R/L105.1833.04.2.HV6				.591	1.181									▲▲
R/L105.1833.04.3.HV6				.787	1.378									▲▲
R/L105.1833.04.4.HV6	.130	.224	.185	.984	1.575	.020	.236	.016						▲▲
R/L105.1833.04.5.HV6				1.181	1.772									▲▲
R/L105.1840.04.2.HV7				.591	1.181									▲▲
R/L105.1840.04.3.HV7				.787	1.378									▲▲
R/L105.1840.04.4.HV7	.157	.252	.205	.984	1.575	.020	.268	.016						▲▲
R/L105.1840.04.5.HV7				1.181	1.772									▲▲

- ▲ on stock Δ 4 weeks
- main recommendation
- alternative recommendation
- uncoated grades
- coated grades
- brazed/Cermet

P					●
M					●
K					●
S					●
N					●
H					

Dimensions in inch

Carbide grades

State R or L version

INSERT Type

105

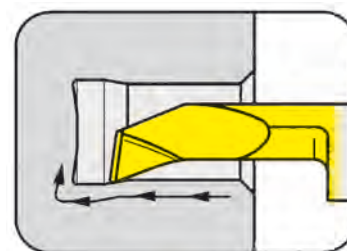

Bore Ø from .157"

for use with Toolholder

- Type BU105
 B105
 B105C
 B105KM
 BKT
 H105
 HC105
 VDI

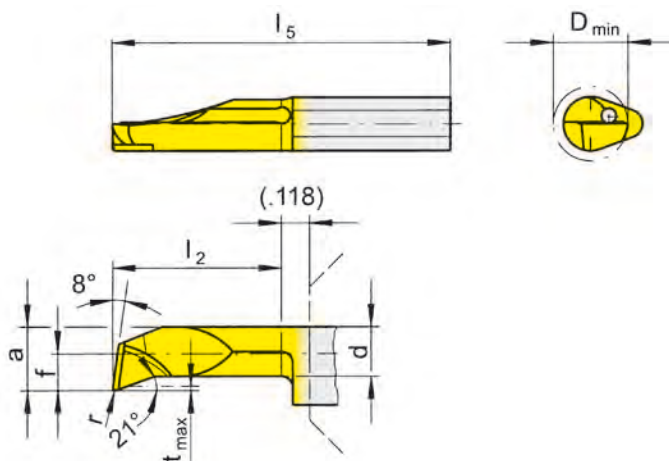

R = right hand version shown

L = left hand version

with chip breaker
(geometry H)

Part number	f	a	d	l ₂	l ₅	t _{max}	D _{min}	r	Carbide grades					
									MG12	TN35	TI25	TF45	TH35	
R/L105.1819.1.H4				.394	.984							▲▲	▲▲	
R/L105.1819.2.H4	.075	.146	.114	.591	1.181	.012	.157	.008				▲▲	▲▲	▲▲
R/L105.1819.3.H4				.787	1.378							▲▲	▲▲	
R/L105.1823.1.H5				.394	.984							▲▲	▲▲	▲▲
R/L105.1823.2.H5				.591	1.181							▲▲	▲▲	▲▲
R/L105.1823.3.H5	.091	.185	.157	.787	1.378	.020	.197	.008				▲▲	▲▲	▲▲
R/L105.1823.4.H5				.984	1.575							▲▲	▲▲	▲▲
R/L105.1823.5.H5				1.181	1.772							▲▲	▲▲	▲▲
R/L105.1833.2.H6				.591	1.181							▲▲	▲▲	▲▲
R/L105.1833.3.H6				.787	1.378							▲▲	▲▲	▲▲
R/L105.1833.4.H6	.130	.224	.185	.984	1.575	.020	.236	.008				▲▲	▲▲	▲▲
R/L105.1833.5.H6				1.181	1.772							▲▲	▲▲	▲▲
R/L105.1840.3.H7				.787	1.378							▲▲	▲▲	▲▲
R/L105.1840.4.H7	.157	.252	.205	.984	1.575	.020	.268	.008				▲▲	▲▲	▲▲
R/L105.1840.5.H7				1.181	1.772							▲▲	▲▲	▲▲

- ▲ on stock ▲ 4 weeks
- main recommendation
- alternative recommendation
- uncoated grades
- coated grades
- brazed/Cermet

P			●	●
M			●	●
K			●	●
S			●	●
N			●	●
H				

Dimensions in inch
 State R or L version

Carbide grades

INSERT Type

105

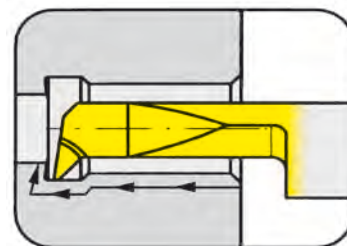

Bore Ø from .157''

for use with Toolholder

- Type
- BU105
 - B105
 - B105C
 - B105KM
 - BKT
 - H105
 - HC105
 - VDI

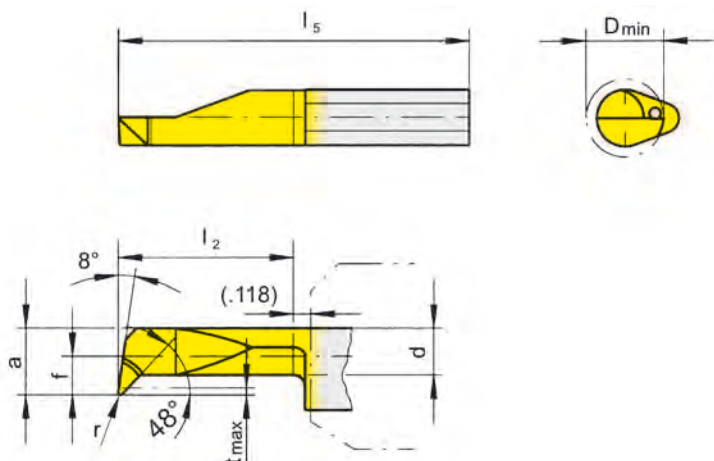

R = right hand version shown

L = left hand version

Part number	f	a	d	l ₂	l ₅	t _{max}	D _{min}	r	Carbide grades				
									MG12	TN35	TI25	TF45	TH35
R/L105.4719.1.4	.075	.146	.114	.394	.984	.024	.157	.006					▲/▲
R/L105.4719.3.4									▲/▲	▲/▲		▲/▲	
R/L105.4723.2.5	.091	.185	.146	.591	1.181	.031	.197	.006					▲/▲
R/L105.4723.4.5									▲/▲	▲/▲		▲/▲	
R/L105.4733.3.6	.130	.224	.146	.787	1.378	.071	.236	.006					▲/▲
R/L105.4733.5.6									▲/▲	Δ/		▲/▲	
									P	•	•		•
									M	•	•		•
									K	•	•		•
									S	•	•		•
									N	•	•		•
									H				

- ▲ on stock Δ 4 weeks
- main recommendation
- o alternative recommendation
- uncoated grades
- coated grades
- brazed/Cermet

Dimensions in inch

State R or L version

Carbide grades

INSERT Type

105
reinforced version

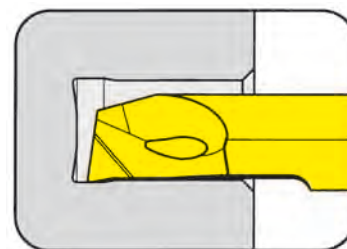

Bore Ø from .157''

for use with Toolholder

- Type BU105
B105
B105C
B105KM
BKT
H105
HC105
VDI

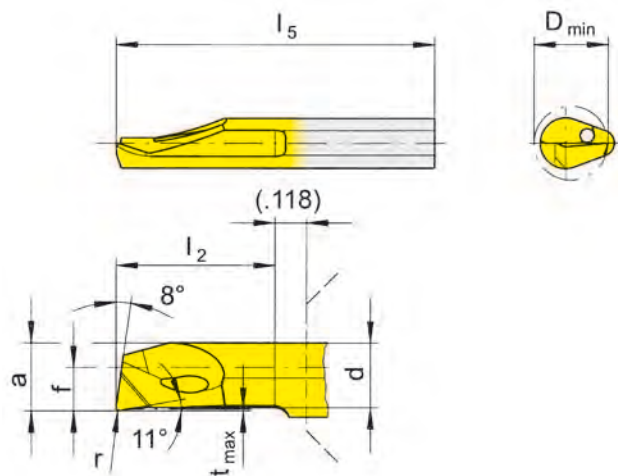

R = right hand version shown

L = left hand version

Part number	f	a	d	l ₂	l ₅	t _{max}	D _{min}	r	Carbide grades				
									MG12	TN35	TI25	TF45	TH35
R/L105.1019.005.1.4				.394	.984								▲▲
R/L105.1019.005.2.4				.591	1.181								▲▲
R/L105.1019.005.3.4	.059	.146	.134	.787	1.378	.006	.157	.002					▲▲
R/L105.1019.005.4.4				.984	1.575								▲▲
R/L105.1019.1.4				.394	.984								▲▲
R/L105.1019.2.4				.591	1.181								▲▲
R/L105.1019.3.4	.059	.146	.134	.787	1.378	.006	.157	.008					▲▲
R/L105.1019.4.4				.984	1.575								▲▲

- ▲ on stock Δ 4 weeks
- main recommendation
- alternative recommendation
- uncoated grades
- coated grades
- brazed/Cermet

P				●
M				●
K				●
S				●
N				●
H				

Carbide grades

Dimensions in inch

State R or L version

INSERT Type

105

reinforced version

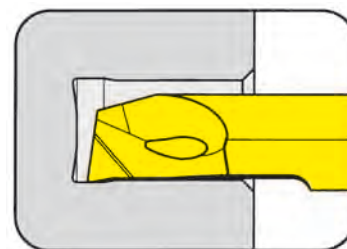

Bore Ø from .197''

for use with Toolholder

- Type
- BU105
 - B105
 - B105C
 - B105KM
 - BKT
 - H105
 - HC105
 - VDI

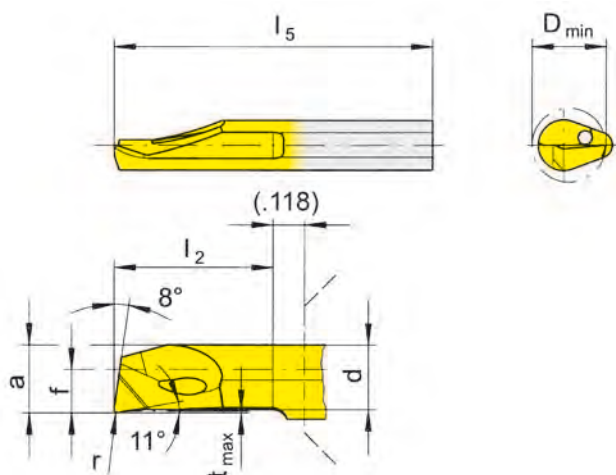

R = right hand version shown

L = left hand version

Part number	f	a	d	l ₂	l ₅	t _{max}	D _{min}	r	Carbide grades				
									MG12	TN35	TI25	TF45	TH35
R/L105.1023.005.1.5				.394	.984								▲▲
R/L105.1023.005.2.5				.591	1.181								▲▲
R/L105.1023.005.3.5	.110	.185	.173	.787	1.378	.006	.197	.002					▲▲
R/L105.1023.005.4.5				.984	1.575								▲▲
R/L105.1023.005.5.5				1.181	1.772								▲▲
R/L105.1023.005.6.5				1.378	1.969								▲▲
R/L105.1023.1.5				.394	.984								▲▲
R/L105.1023.2.5				.591	1.181								▲▲
R/L105.1023.3.5	.110	.185	.173	.787	1.378	.006	.197	.008					▲▲
R/L105.1023.4.5				.984	1.575								▲▲
R/L105.1023.5.5				1.181	1.772								▲▲
R/L105.1023.6.5				1.378	1.969								▲▲
▲ on stock Δ 4 weeks ● main recommendation ○ alternative recommendation □ uncoated grades ■ coated grades ■ brazed/Cermet									P				●
									M				●
									K				●
									S				●
									N				●
									H				

Dimensions in inch

Carbide grades

State R or L version

INSERT Type

105

reinforced version

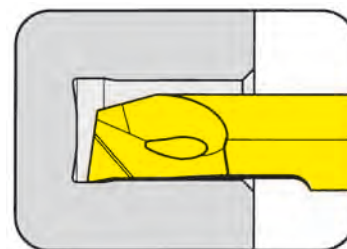

Bore Ø from .236''

for use with Toolholder

- Type
- BU105
 - B105
 - B105C
 - B105KM
 - BKT
 - H105
 - HC105
 - VDI

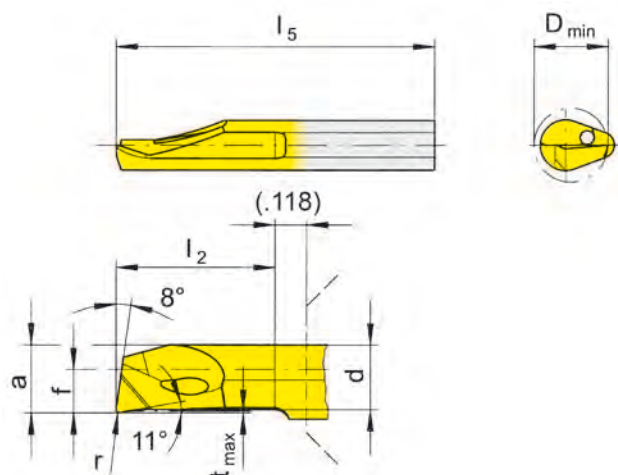

R = right hand version shown

L = left hand version

Part number	f	a	d	l ₂	l ₅	t _{max}	D _{min}	r	Carbide grades					
									MG12	TN35	TI25	TF45	TH35	
R/L105.1033.005.1.6				.394	.984									▲▲
R/L105.1033.005.2.6				.591	1.181									▲▲
R/L105.1033.005.3.6	.130	.224	.213	.787	1.378	.006	.236	.002						▲▲
R/L105.1033.005.4.6				.984	1.575									▲▲
R/L105.1033.005.5.6				1.181	1.772									▲▲
R/L105.1033.005.6.6				1.378	1.969									▲▲
R/L105.1033.1.6				.394	.984									▲▲
R/L105.1033.2.6				.591	1.181									▲▲
R/L105.1033.3.6	.130	.224	.213	.787	1.378	.006	.236	.008						▲▲
R/L105.1033.4.6				.984	1.575									▲▲
R/L105.1033.5.6				1.181	1.772									▲▲
R/L105.1033.6.6				1.378	1.969									▲▲
▲ on stock Δ 4 weeks ● main recommendation ○ alternative recommendation □ uncoated grades ■ coated grades ■ brazed/Cermet									P				●	
									M				●	
									K				●	
									S				●	
									N				●	
									H					

Dimensions in inch

Carbide grades

State R or L version

INSERT Type

105

reinforced version

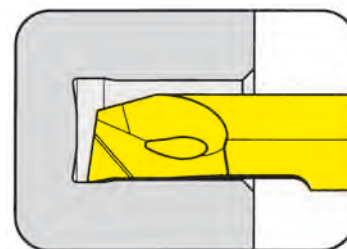

Bore Ø from .268''

for use with Toolholder

- Type
- BU105
 - B105
 - B105C
 - B105KM
 - BKT
 - H105
 - HC105
 - VDI

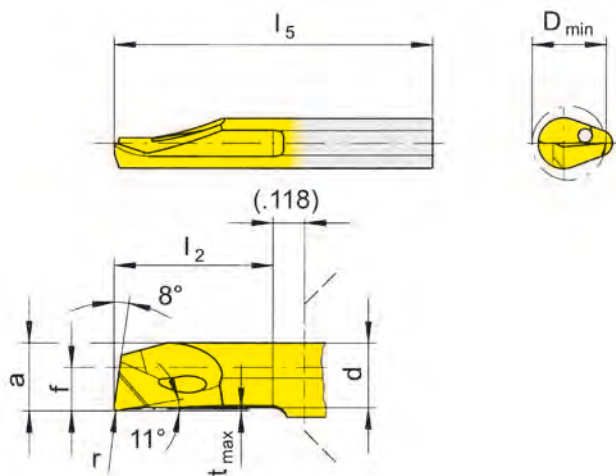

R = right hand version shown

L = left hand version

Part number	f	a	d	l ₂	l ₅	t _{max}	D _{min}	r	Carbide grades				
									MG12	TN35	TI25	TF45	TH35
R/L105.1040.1.7				.394	.984								▲▲
R/L105.1040.2.7				.591	1.181								▲▲
R/L105.1040.3.7	.157	.252	.240	.787	1.378	.006	.268	.008					▲▲
R/L105.1040.4.7				.984	1.575								▲▲
R/L105.1040.5.7				1.181	1.772								▲▲
R/L105.1040.6.7				1.378	1.969								▲▲
▲ on stock Δ 4 weeks ● main recommendation ○ alternative recommendation □ uncoated grades ■ coated grades ■ brazed/Cermet									P				●
									M				●
									K				●
									S				●
									N				●
									H				

Dimensions in inch

Carbide grades

State R or L version

INSERT Type

105

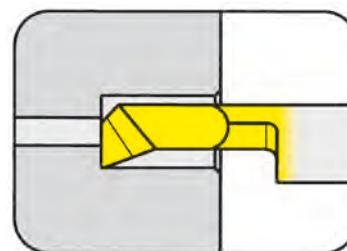

Bore Ø from .118''

for use with Toolholder

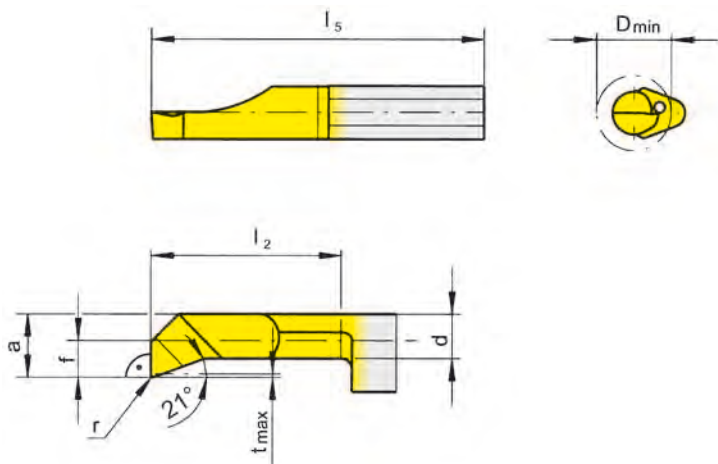

- Type BU105
 B105
 B105C
 B105KM
 BKT
 H105
 HC105
 VDI

R = right hand version shown

L = left hand version

Part number	f	a	d	l ₂	l ₅	t _{max}	D _{min}	r	Carbide grades				
									MG12	TN35	TI25	TF45	TH35
R/L105.9013.01.1.3	.051	.102	.091	.394	.984	.006	.118	.004					▲/▲
R/L105.9013.01.2.3				.591	1.181								
R/L105.9013.1.3				.394	.984								
R/L105.9013.2.3				.591	1.181								
R/L105.9019.01.1.4	.075	.146	.114	.394	.984	.012	.157	.004					▲/▲
R/L105.9019.01.2.4				.591	1.181								
R/L105.9019.01.3.4				.787	1.378								
R/L105.9019.1.4				.394	.984								
R/L105.9019.2.4				.591	1.181								

- ▲ on stock Δ 4 weeks
- main recommendation
- alternative recommendation
- uncoated grades
- coated grades
- brazed/Cermet

Dimensions in inch
 State R or L version

Carbide grades

INSERT Type

105

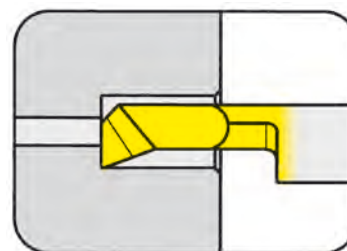

Bore Ø from .197''

for use with Toolholder

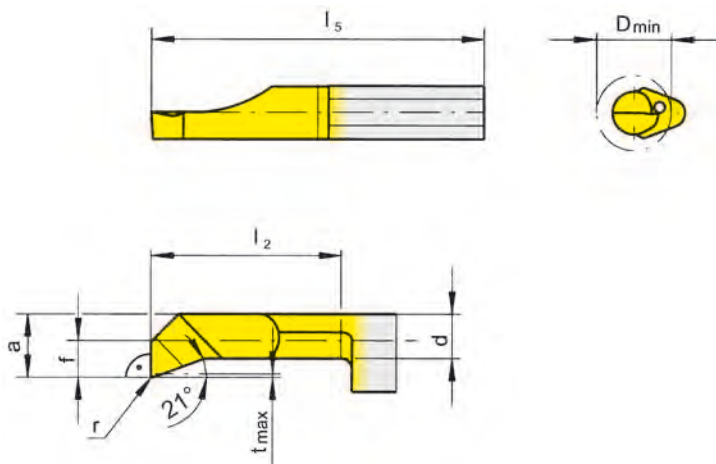

- Type BU105
B105
B105C
B105KM
BKT
H105
HC105
VDI

R = right hand version shown

L = left hand version

Part number	f	a	d	l ₂	l ₅	t _{max}	D _{min}	r	Carbide grades					
									MG12	TN35	TI25	TF45	TH35	
R/L105.9023.01.1.5				.394	.984			.004						▲/▲
R/L105.9023.01.2.5				.591	1.181			.004						▲/▲
R/L105.9023.01.3.5				.787	1.378			.004						▲/▲
R/L105.9023.01.4.5	.091	.185	.157	.984	1.575	.020	.197	.004						▲/
R/L105.9023.1.5				.394	.984			.008		▲/▲				▲/
R/L105.9023.2.5				.591	1.181			.008		▲/▲				
R/L105.9023.3.5				.787	1.378			.008		▲/▲				
R/L105.9033.1.6				.394	.984									Δ/
R/L105.9033.2.6				.591	1.181									Δ/Δ
R/L105.9033.3.6	.130	.224	.185	.787	1.378	.020	.236	.008						Δ/Δ
R/L105.9033.4.6				.984	1.575									Δ/Δ
R/L105.9033.5.6				1.181	1.772									Δ/Δ
▲ on stock Δ 4 weeks ● main recommendation ○ alternative recommendation □ uncoated grades ■ coated grades ■ brazed/Cermet									P	●	■	■	●	
									M	●	■	■	●	
									K	●	■	■	●	
									S	●	■	■	●	
									N	●	■	■	●	
									H					

Dimensions in inch

Carbide grades

State R or L version

INSERT Type

105

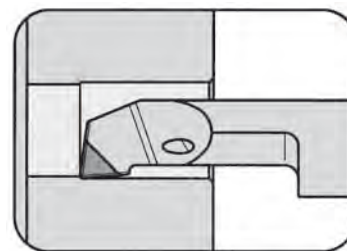

Bore Ø from .118"

for use with Toolholder

- Type BU105
 B105
 B105C
 B105KM
 BKT
 H105
 HC105
 VDI

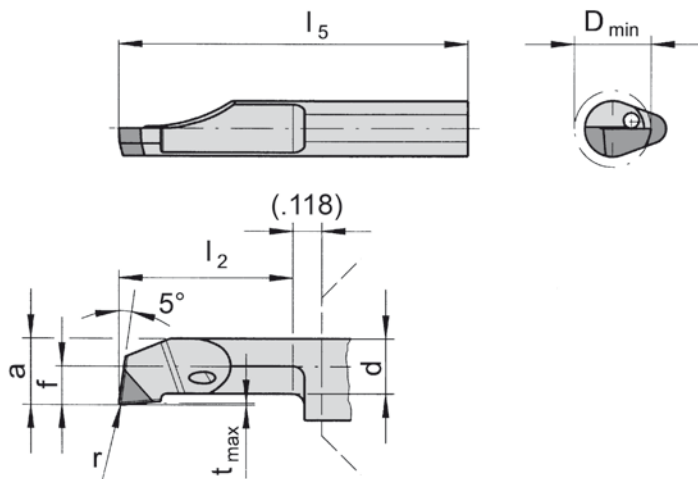

R = right hand version shown

CBN tipped

Part number	f	a	d	l ₂	l ₅	t _{max}	D _{min}	r	CB10
R105.0513.0.3.B	.051	.106	.098	.276	.984	.004	.118	.006	▲
R105.0519.1.4.B	.059	.146	.134	.394	.984	.004	.157	.008	▲
R105.0523.2.5.B	.091	.185	.173	.591	1.181	.004	.197	.008	▲
R105.0533.2.6.B	.130	.224	.209	.591	1.181	.006	.236	.008	▲
R105.0533.3.6.B	.130	.224	.209	.787	1.378	.006	.236	.008	△
R105.0540.2.7.B	.157	.252	.236	.591	1.181	.006	.268	.008	▲

- ▲ on stock △ 4 weeks
- main recommendation
- alternative recommendation
- uncoated grades
- coated grades
- brazed/Cermet

P	■
M	■
K	■
S	■
N	■
H	●

Carbide grades

Dimensions in inch

INSERT Type

105

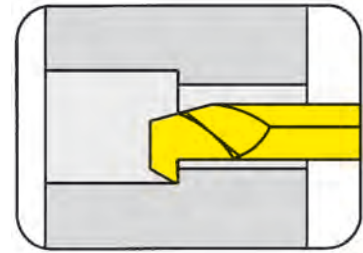

Bore Ø from .118"

for use with Toolholder

- Type BU105
 B105
 B105C
 B105KM
 BKT
 H105
 HC105
 VDI

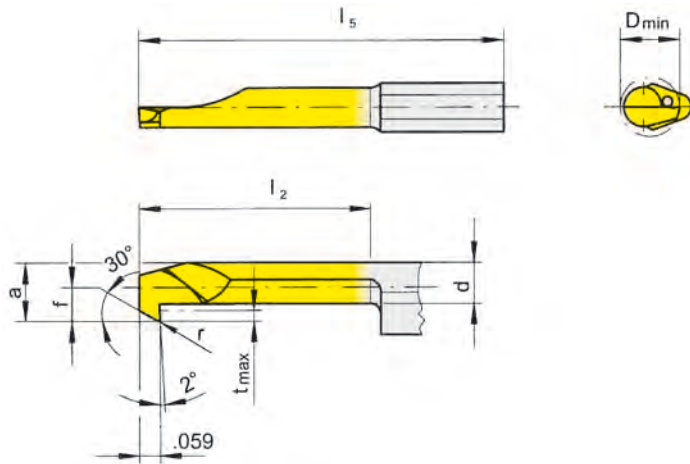

R = right hand version shown

L = left hand version

Part number	f	a	d	l ₂	l ₅	t _{max}	D _{min}	r	Carbide grades				
									MG12	TN35	TI25	TF45	TH35
R/L105.3013.2.3 R/L105.3013.3.3	.051	.102	.075	.591 .787	1.181 1.378	.020	.118	.004			▲/▲ ▲/Δ		
R/L105.3019.2.4 R/L105.3019.4.4	.075	.146	.106	.591 .984	1.181 1.575	.031	.157	.006			▲/▲ ▲/Δ		
R/L105.3023.3.5 R/L105.3023.5.5	.091	.185	.138	.787 1.181	1.378 1.772	.039	.197	.008			▲/▲ ▲/Δ		
R/L105.3033.3.6 R/L105.3033.5.6	.130	.224	.146	.787 1.181	1.378 1.772	.071	.236	.008			▲/▲ ▲/Δ		
R/L105.3040.3.7 R/L105.3040.5.7	.157	.252	.146	.787 1.181	1.378 1.772	.098	.268	.008			▲/▲ ▲/▲		

- ▲ on stock Δ 4 weeks
- main recommendation
- alternative recommendation

- uncoated grades
- coated grades
- brazed/Cermet

Dimensions in inch

State R or L version

P			●		
M			●		
K			●		
S			●		
N			●		
H					

Carbide grades

INSERT Type

105

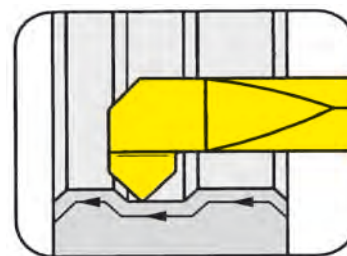

Bore Ø from .197"

for use with Toolholder

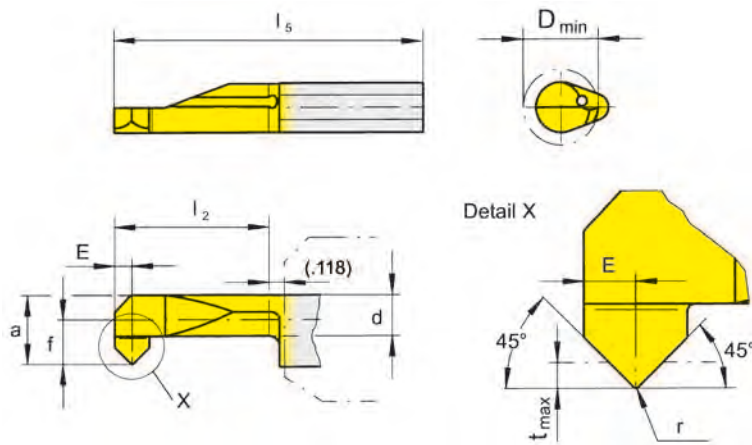

- Type BU105
 B105
 B105C
 B105KM
 BKT
 H105
 HC105
 VDI

R = right hand version shown

L = left hand version

Part number	E	f	a	d	l ₂	l ₅	t _{max}	D _{min}	r	Carbide grades				
										MG12	TN35	TI25	TF45	TH35
R/L105.4545.2.5	.039	.091	.185	.138	.591	1.181	.028	.197	.008		▲/▲			
R/L105.4545.3.7	.039	.157	.252	.185	.787	1.378	.028	.276	.008		▲/▲			
										P	•			
										M	•			
										K	•			
										S	•			
										N	•			
										H				

- ▲ on stock Δ 4 weeks
- main recommendation
- o alternative recommendation
- uncoated grades
- coated grades
- brazed/Cermet

Dimensions in inch

State R or L version

Carbide grades

INSERT Type

105

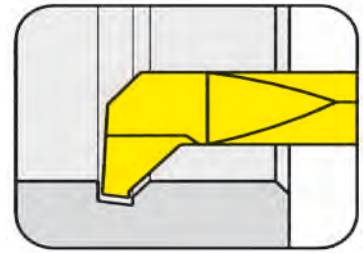

Bore Ø from .197"

for use with Toolholder

- Type BU105
 B105
 B105C
 B105KM
 BKT
 H105
 HC105
 VDI

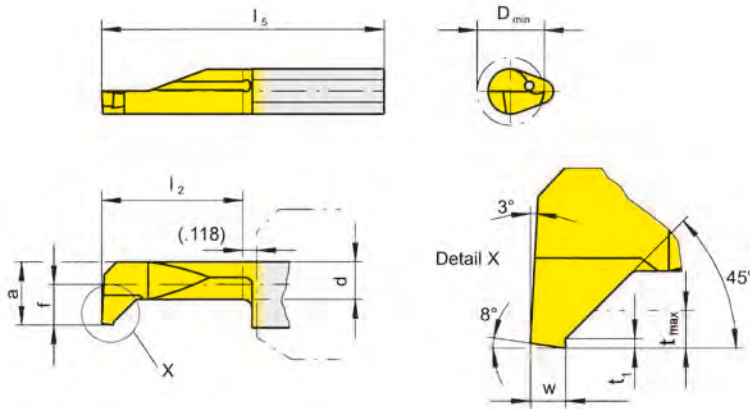

R = right hand version shown

L = left hand version

Part number	w	f	a	d	l ₂	l ₅	t ₁	t _{max}	D _{min}	Carbide grades					
										MG12	TN35	TI25	TF45	TH35	
R/L105.0810.2.5					.591	1.181					▲/▲	▲/▲	●	●	
R/L105.0810.3.5	.039	.091	.185	.138	.787	1.378	.008	.028	.197		▲/▲	▲/▲	▲/▲		
R/L105.0810.4.5					.984	1.575					▲/▲	▲/▲	▲/▲		
											P	o	●	●	
											M	●	●	●	
											K	●	●	●	
											S	●	●	●	
											N	●	●	●	
											H				

- ▲ on stock Δ 4 weeks
- main recommendation
- o alternative recommendation
- uncoated grades
- coated grades
- brazed/Cermet

Dimensions in inch

State R or L version

Carbide grades

GROOVING (internal) $\geq \text{Ø} .079''$



INSERT Type

105

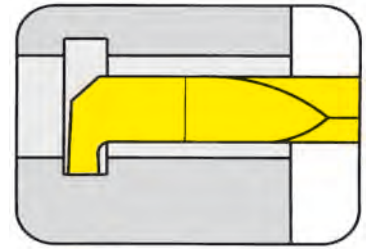

Bore Ø from	.079"
Depth of groove up to	.016"

for use with Toolholder

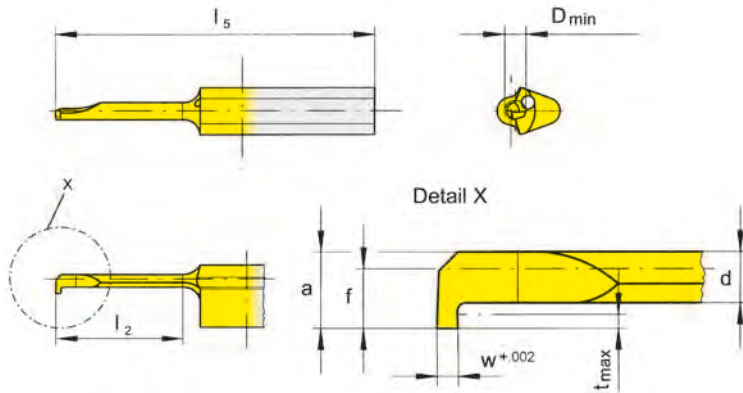

- Type
- BU105
 - B105
 - B105C
 - B105KM
 - BKT
 - H105
 - HC105
 - VDI

R = right hand version shown

L = left hand version

Part number	w	f	a	d	l ₂	l ₅	t _{max}	D _{min}	Carbide grades					
									MG12	TN35	TI25	TF45	TH35	
R/L105.0050.0.2					.236	.984					▲▲			
R/L105.0050.1.2	.020	.055	.071	.047	.354	.984	.016	.079			▲▲			
R/L105.0050.2.2					.472	1.181					▲/▲			
											●			
											●			
											●			
											●			
											●			
											●			

- ▲ on stock Δ 4 weeks
- main recommendation
- alternative recommendation
- uncoated grades
- coated grades
- brazed/Cermet

Dimensions in inch

State R or L version

Carbide grades

GROOVING (internal) $\geq \text{Ø} .118''$



INSERT Type

105

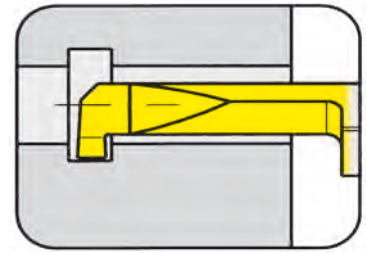

Bore Ø from .118"
 Depth of groove up to .024"

for use with Toolholder

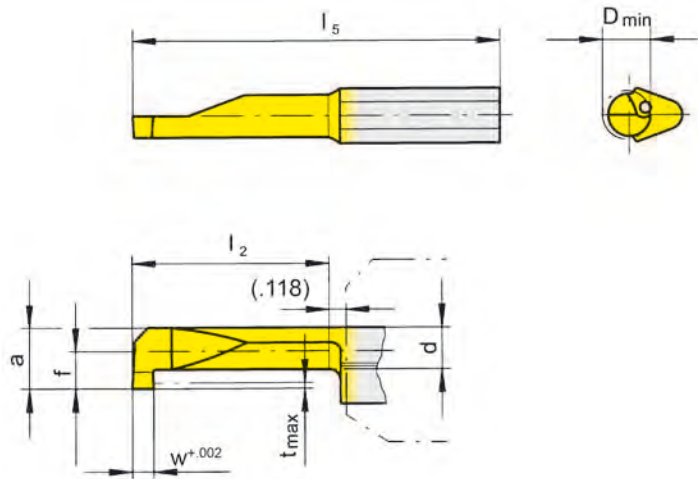

- Type BU105
 B105
 B105C
 B105KM
 BKT
 H105
 HC105
 VDI

R = right hand version shown

L = left hand version

Part number	w	f	a	d	l ₂	l ₅	t _{max}	D _{min}	Carbide grades					
									MG12	TN35	TI25	TF45	TH35	
R/L105.0070.1.3					.315	.984					▲▲			
R/L105.0070.2.3	.028	.055	.106	.075	.472	1.181	.024	.118			▲▲			
R/L105.0070.3.3					.630	1.378					▲▲			
											●			
											●			
											●			
											●			
											●			
											●			

- ▲ on stock Δ 4 weeks
- main recommendation
- alternative recommendation
- uncoated grades
- coated grades
- brazed/Cermet

Dimensions in inch

State R or L version

Carbide grades

GROOVING (internal) $\geq \text{Ø} .157''$



INSERT Type

105

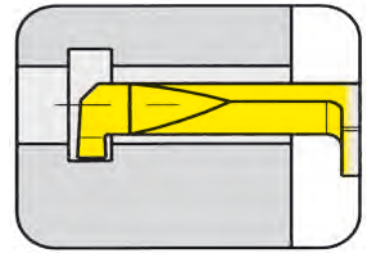

Bore Ø from .157''
 Depth of groove up to .031''

for use with Toolholder

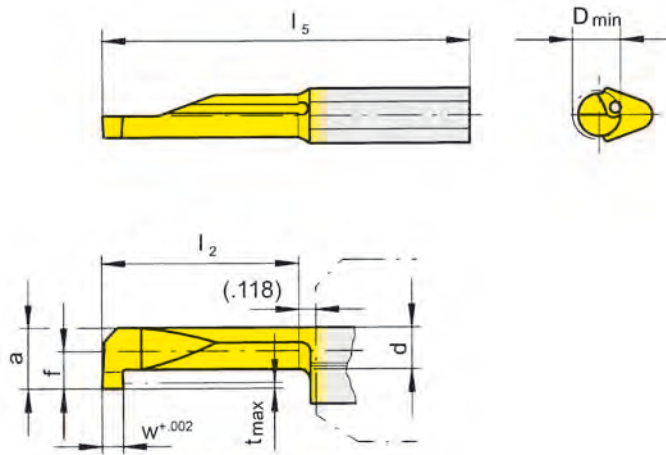

- Type BU105
 B105
 B105C
 B105KM
 BKT
 H105
 HC105
 VDI

R = right hand version shown

L = left hand version

Part number	w	f	a	d	l ₂	l ₅	t _{max}	D _{min}	Carbide grades				
									MG12	TN35	TI25	TF45	TH35
R/L105.0100.1.4					.394	.984			▲/▲	▲/▲			
R/L105.0100.2.4	.039	.075	.146	.106	.591	1.181	.031	.157	▲/▲	▲/▲			
R/L105.0100.3.4					.787	1.378			▲/▲	▲/▲			
									P	o	•		
									M	•	•		
									K	•	•		
									S	•	•		
									N	•	•		
									H				

- ▲ on stock Δ 4 weeks
- main recommendation
- o alternative recommendation
- uncoated grades
- coated grades
- brazed/Cermet

Dimensions in inch

State R or L version

Carbide grades

GROOVING (internal) $\geq \text{Ø} .157''$



INSERT Type

U105

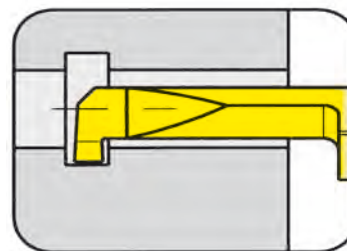

Bore Ø from .157''
 Depth of groove up to .031''

for use with Toolholder

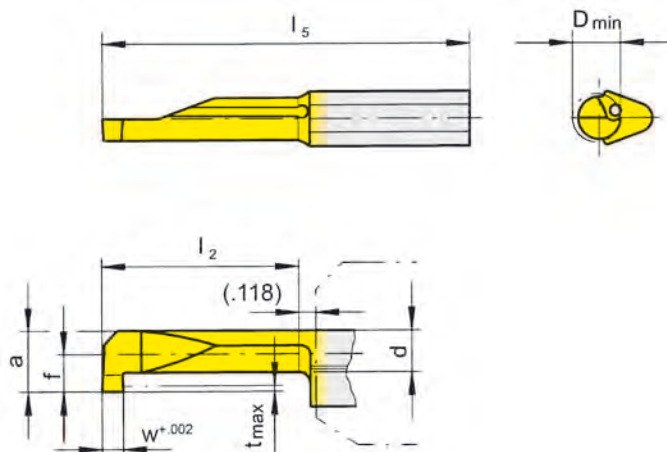

- Type BU105
 B105
 B105C
 B105KM
 BKT
 H105
 HC105
 VDI

R = right hand version shown

L = left hand version

Part number	w	f	a	d	l ₂	l ₅	t _{max}	D _{min}	Carbide grades					
									MG12	TN35	TI25	TF45	TH35	
R/LU105.0031.1.4					.394	.984				▲/▲				▲/
R/LU105.0031.2.4	.031	.075	.146	.106	.591	1.181	.031	.157	▲/	▲/▲				▲/
R/LU105.0031.3.4					.787	1.378				▲/▲				▲/
									P	o	•			•
									M	•	•			•
									K	•	•			•
									S	•	•			•
									N	•	•			•
									H					

- ▲ on stock Δ 4 weeks
- main recommendation
- o alternative recommendation
- uncoated grades
- coated grades
- brazed/Cermet

Dimensions in inch

State R or L version

Carbide grades

GROOVING (internal) $\geq \text{Ø} .197''$



INSERT Type

105

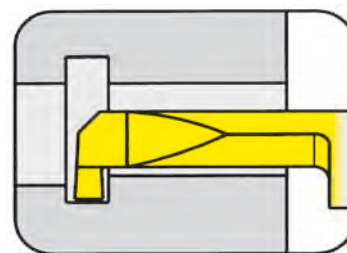

Bore Ø from $.197''$
 Depth of groove up to $.039''$

for use with Toolholder

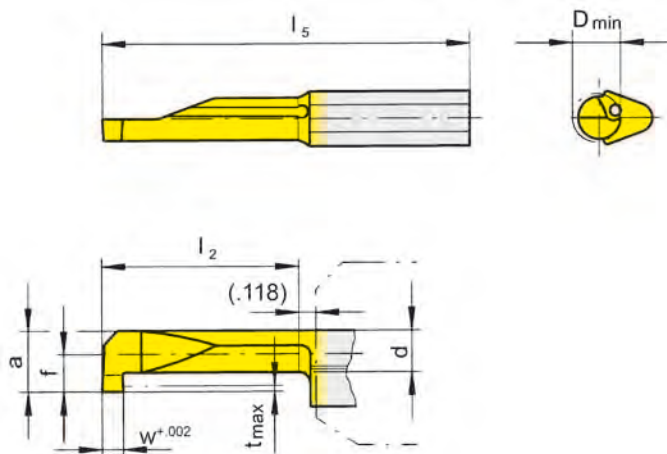

- Type BU105
 B105
 B105C
 B105KM
 BKT
 H105
 HC105
 VDI

R = right hand version shown

L = left hand version

Part number	w	f	a	d	l ₂	l ₅	t _{max}	D _{min}	Carbide grades				
									MG12	TN35	TI25	TF45	TH35
R/L105.0100.1.5	.039								▲/▲	▲/▲			▲/▲
R/L105.0150.1.5	.059	.091	.185	.138	.394	.984	.039	.197	▲/▲	▲/▲			▲/▲
R/L105.0200.1.5	.079								▲/▲	▲/▲			▲/▲
R/L105.0100.2.5	.039								▲/▲	▲/▲			▲/▲
R/L105.0150.2.5	.059	.091	.185	.138	.591	1.181	.039	.197	▲/▲	▲/▲			▲/▲
R/L105.0200.2.5	.079								▲/▲	▲/▲			▲/▲
R/L105.0100.3.5	.039								▲/▲	▲/▲			▲/▲
R/L105.0150.3.5	.059	.091	.185	.138	.787	1.378	.039	.197	▲/▲	▲/▲			▲/▲
R/L105.0200.3.5	.079								▲/	▲/▲			▲/▲
R/L105.0100.4.5	.039									▲/▲			▲/▲
R/L105.0150.4.5	.059	.091	.185	.138	.984	1.575	.039	.197		▲/▲			▲/▲
R/L105.0200.4.5	.079									▲/▲			▲/▲
R/L105.0100.5.5	.039									▲/▲			▲/▲
R/L105.0150.5.5	.059	.091	.185	.138	1.181	1.772	.039	.197		▲/▲			▲/▲
R/L105.0200.5.5	.079									▲/▲			▲/▲

- ▲ on stock Δ 4 weeks
- main recommendation
- alternative recommendation
- uncoated grades
- coated grades
- brazed/Cermet

P	○	●		●
M	●	●		●
K	●	●		●
S	●	●		●
N	●	●		●
H				

Carbide grades

Dimensions in inch

State R or L version

GROOVING (internal) $\geq \text{Ø} .197''$



A

INSERT Type

U105

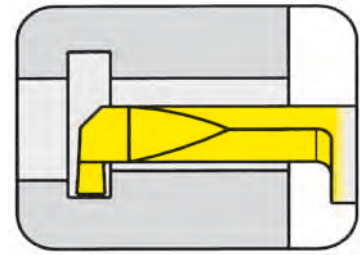

Bore Ø from $.197''$
Depth of groove up to $.039''$

for use with Toolholder

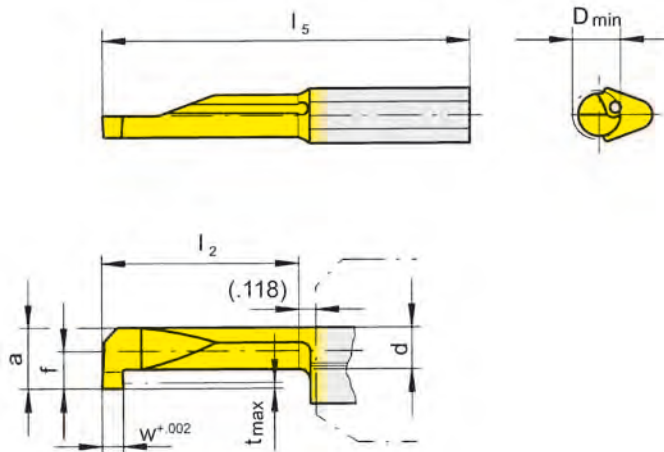

Type BU105
B105
B105C
B105KM
BKT
H105
HC105
VDI

R = right hand version shown

L = left hand version

Part number	w	f	a	d	l ₂	l ₅	t _{max}	D _{min}	Carbide grades					
									MG12	TN35	TI25	TF45	TH35	
R/LU105.0031.1.5	.031									▲/▲				▲/
R/LU105.0046.1.5	.046									▲/▲	Δ			▲/
R/LU105.0062.1.5	.062	.091	.185	.138	.394	.984	.039	.197		▲/▲				▲/
R/LU105.0078.1.5	.078									▲/▲				▲/
R/LU105.0031.2.5	.031									▲/▲				▲/
R/LU105.0046.2.5	.046									▲/▲				▲/
R/LU105.0062.2.5	.062	.091	.185	.138	.591	1.181	.039	.197		▲/▲				▲/
R/LU105.0078.2.5	.078									▲/▲				▲/
R/LU105.0031.3.5	.031									▲/▲				▲/
R/LU105.0046.3.5	.046									▲/▲				▲/
R/LU105.0062.3.5	.062	.091	.185	.138	.787	1.378	.039	.197		▲/▲				▲/
R/LU105.0078.3.5	.078									▲/▲				▲/
R/LU105.0031.4.5	.031									▲/▲				▲/
R/LU105.0046.4.5	.046									▲/▲				▲/
R/LU105.0062.4.5	.062	.091	.185	.138	.984	1.575	.039	.197		▲/▲				▲/
R/LU105.0078.4.5	.078									▲/▲				▲/
R/LU105.0031.5.5	.031									▲/▲				▲/
R/LU105.0046.5.5	.046									▲/▲				▲/
R/LU105.0062.5.5	.062	.091	.185	.138	1.181	1.772	.039	.197		▲/▲				▲/
R/LU105.0078.5.5	.078									▲/▲				▲/

- ▲ on stock Δ 4 weeks
- main recommendation
- alternative recommendation
- uncoated grades
- coated grades
- brazed/Cermet

State R or L version

	P	M	K	S	N	H
	●	●	●	●	●	●
	●	●	●	●	●	●
	●	●	●	●	●	●
	●	●	●	●	●	●
	●	●	●	●	●	●
	●	●	●	●	●	●

Dimensions in inch

Carbide grades

GROOVING (internal) $\geq \text{Ø} .236''$



INSERT Type

105

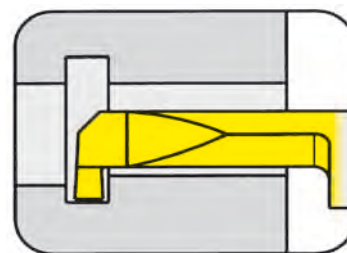

Bore Ø from $.236''$
 Depth of groove up to $.071''$

for use with Toolholder

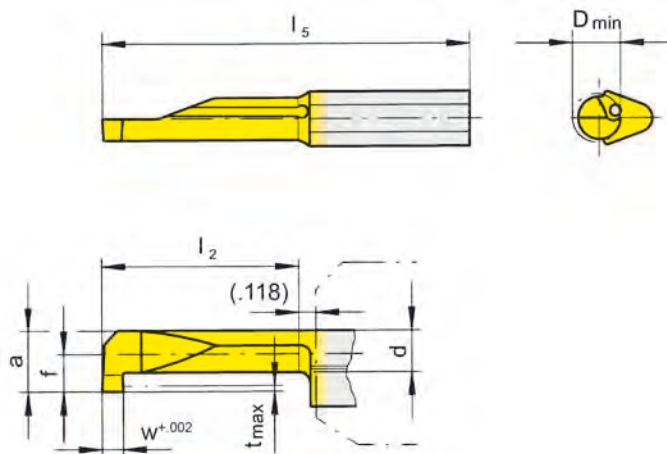

- Type BU105
 B105
 B105C
 B105KM
 BKT
 H105
 HC105
 VDI

R = right hand version shown

L = left hand version

Part number	w	f	a	d	l ₂	l ₅	t _{max}	D _{min}	Carbide grades				
									MG12	TN35	TI25	TF45	TH35
R/L105.0100.1.6	.039								▲/▲	▲/▲			▲/▲
R/L105.0150.1.6	.059	.130	.224	.146	.394	.984	.071	.236	▲/▲	▲/▲			▲/▲
R/L105.0200.1.6	.079								▲/▲	▲/▲			▲/▲
R/L105.0100.2.6	.039								▲/▲	▲/▲			▲/▲
R/L105.0150.2.6	.059	.130	.224	.146	.591	1.181	.071	.236	▲/▲	▲/▲			▲/▲
R/L105.0200.2.6	.079								▲/▲	▲/▲			▲/▲
R/L105.0100.3.6	.039								▲/▲	▲/▲			▲/▲
R/L105.0150.3.6	.059	.130	.224	.146	.787	1.378	.071	.236	▲/▲	▲/▲			▲/▲
R/L105.0200.3.6	.079								▲/▲	▲/▲			▲/▲
R/L105.0100.4.6	.039									▲/▲			▲/▲
R/L105.0150.4.6	.059	.130	.224	.146	.984	1.575	.071	.236		▲/▲			▲/▲
R/L105.0200.4.6	.079									▲/▲			▲/▲
R/L105.0100.5.6	.039										▲/▲		▲/▲
R/L105.0150.5.6	.059	.130	.224	.146	1.181	1.772	.071	.236		▲/▲			▲/▲
R/L105.0200.5.6	.079									▲/▲			/▲

- ▲ on stock Δ 4 weeks
- main recommendation
- alternative recommendation
- uncoated grades
- coated grades
- brazed/Cermet

P	○	●	●	●
M	●	●	●	●
K	●	●	●	●
S	●	●	●	●
N	●	●	●	●
H				

Carbide grades

Dimensions in inch

State R or L version

GROOVING (internal) $\geq \text{Ø} .236''$



A

INSERT Type

U105

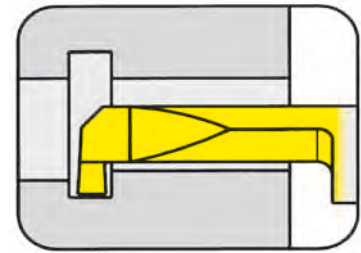

Bore Ø from $.236''$
Depth of groove up to $.071''$

for use with Toolholder

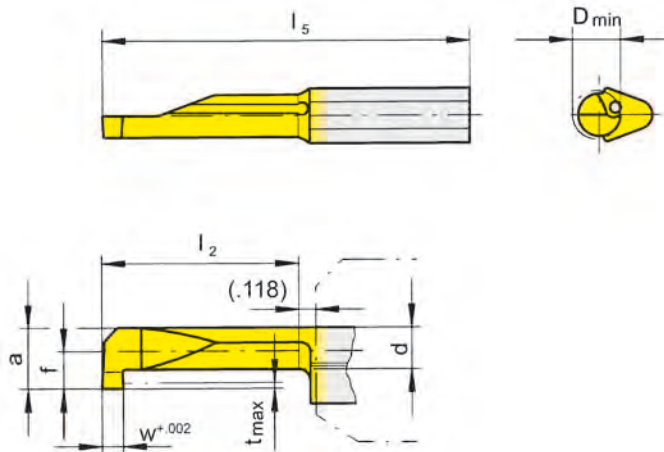

Type BU105
B105
B105C
B105KM
BKT
H105
HC105
VDI

R = right hand version shown

L = left hand version

Part number	w	f	a	d	l ₂	l ₅	t _{max}	D _{min}	Carbide grades				
									MG12	TN35	TI25	TF45	TH35
R/LU105.0031.1.6	.031								▲/	▲/▲			▲/
R/LU105.0046.1.6	.046							.236		▲/▲			▲/
R/LU105.0062.1.6	.062	.130	.224	.146	.394	.984	.071	.236		▲/▲			▲/
R/LU105.0078.1.6	.078								▲/	▲/▲			▲/
R/LU105.0031.2.6	.031									▲/▲			▲/
R/LU105.0046.2.6	.046									▲/▲			▲/
R/LU105.0062.2.6	.062	.130	.224	.146	.591	1.181	.071	.236		▲/▲			▲/
R/LU105.0078.2.6	.078								▲/	▲/▲			▲/
R/LU105.0031.3.6	.031									▲/	▲/▲		▲/
R/LU105.0046.3.6	.046									▲/▲			▲/
R/LU105.0062.3.6	.062	.130	.224	.146	.787	1.378	.071	.236		▲/	▲/▲		▲/
R/LU105.0078.3.6	.078									▲/▲			▲/
R/LU105.0031.4.6	.031									▲/	▲/▲	Δ/	▲/
R/LU105.0046.4.6	.046									▲/▲			▲/
R/LU105.0062.4.6	.062	.130	.224	.146	.984	1.575	.071	.236		▲/▲	Δ/		▲/
R/LU105.0078.4.6	.078									▲/▲			▲/

- ▲ on stock Δ 4 weeks
- main recommendation
- alternative recommendation
- uncoated grades
- coated grades
- brazed/Cermet

P	○	●	●	●	●
M	●	●	●	●	●
K	●	●	●	●	●
S	●	●	●	●	●
N	●	●	●	●	●
H					

Dimensions in inch

Carbide grades

State R or L version

GROOVING (internal) $\geq \text{Ø} .268''$



INSERT Type

105

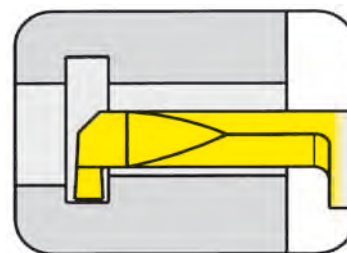

Bore Ø from $.268''$
 Depth of groove up to $.098''$

for use with Toolholder

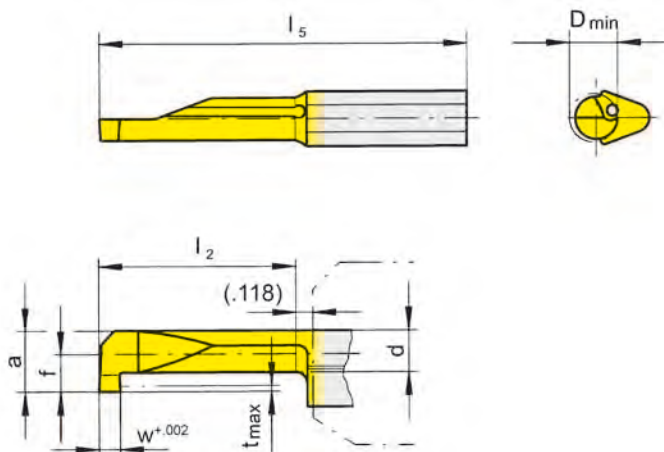

- Type BU105
 B105
 B105C
 B105KM
 BKT
 H105
 HC105
 VDI

R = right hand version shown

L = left hand version

Part number	w	f	a	d	l ₂	l ₅	t _{max}	D _{min}	Carbide grades				
									MG12	TN35	TI25	TF45	TH35
R/L105.0100.1.7	.039								▲/▲	▲/▲			▲/▲
R/L105.0150.1.7	.059	.157	.252	.146	.394	.984	.098	.268	▲/▲	▲/▲			▲/▲
R/L105.0200.1.7	.079								▲/▲	▲/▲			▲/▲
R/L105.0100.2.7	.039								▲/▲	▲/▲			▲/▲
R/L105.0150.2.7	.059	.157	.252	.146	.591	1.181	.098	.268	▲/▲	▲/▲			▲/▲
R/L105.0200.2.7	.079								▲/▲	▲/▲			▲/▲
R/L105.0100.3.7	.039								▲/▲	▲/▲			▲/▲
R/L105.0150.3.7	.059	.157	.252	.146	.787	1.378	.098	.268	▲/▲	▲/▲			▲/▲
R/L105.0200.3.7	.079								▲/▲	▲/▲			▲/▲
R/L105.0100.4.7	.039									▲/▲			▲/▲
R/L105.0150.4.7	.059	.157	.252	.146	.984	1.575	.098	.268		▲/▲			▲/▲
R/L105.0200.4.7	.079									▲/▲			▲/▲
R/L105.0100.5.7	.039										▲/▲		▲/▲
R/L105.0150.5.7	.059	.157	.252	.146	1.181	1.772	.098	.268		▲/▲			▲/▲
R/L105.0200.5.7	.079									▲/▲			▲/▲

- ▲ on stock Δ 4 weeks
- main recommendation
- alternative recommendation
- uncoated grades
- coated grades
- brazed/Cermet

P	○	●		●	
M	●	●		●	
K	●	●		●	
S	●	●		●	
N	●	●		●	
H					

Carbide grades

Dimensions in inch

State R or L version

GROOVING (internal) $\geq \text{Ø} .268''$



A

INSERT Type

U105

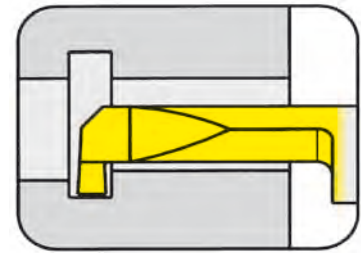

Bore Ø from $.268''$
Depth of groove up to $.098''$

for use with Toolholder

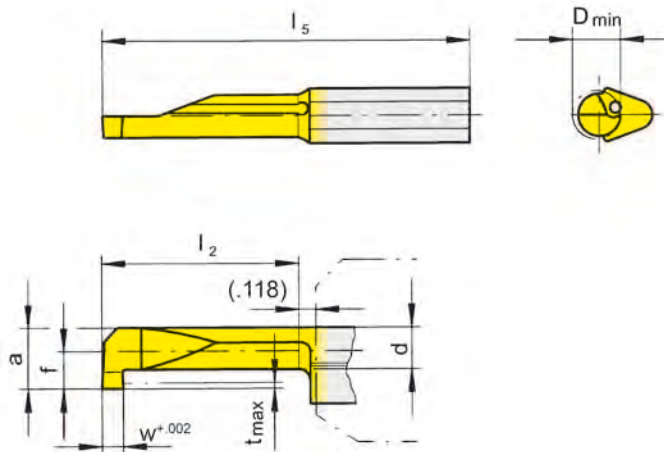

- Type BU105
B105
B105C
B105KM
BKT
H105
HC105
VDI

R = right hand version shown

L = left hand version

Part number	w	f	a	d	l ₂	l ₅	t _{max}	D _{min}	Carbide grades				
									MG12	TN35	TI25	TF45	TH35
R/LU105.0031.1.7	.031								▲/	▲/▲			▲/
R/LU105.0046.1.7	.046							.268		▲/▲	Δ/		▲/
R/LU105.0062.1.7	.062	.157	.252	.146	.394	.984	.098	.268		▲/▲			▲/
R/LU105.0078.1.7	.078								▲/	▲/▲			▲/
R/LU105.0031.2.7	.031								▲/	▲/▲			▲/
R/LU105.0046.2.7	.046									▲/▲			▲/
R/LU105.0062.2.7	.062	.157	.252	.146	.591	1.181	.098	.268		▲/▲			▲/
R/LU105.0078.2.7	.078								▲/	▲/▲			▲/
R/LU105.0031.3.7	.031								▲/	▲/▲			▲/
R/LU105.0046.3.7	.046									▲/▲			▲/
R/LU105.0062.3.7	.062	.157	.252	.146	.787	1.378	.098	.268	▲/	▲/▲			▲/
R/LU105.0078.3.7	.078									▲/▲			▲/
R/LU105.0031.4.7	.031									▲/▲			▲/
R/LU105.0046.4.7	.046									▲/Δ			▲/
R/LU105.0062.4.7	.062	.157	.252	.146	.984	1.575	.098	.268		▲/▲			▲/
R/LU105.0078.4.7	.078									▲/▲			▲/
R/LU105.0031.5.7	.031									▲/			▲/
R/LU105.0046.5.7	.046									▲/▲			▲/
R/LU105.0062.5.7	.062	.157	.252	.146	1.181	1.772	.098	.268		▲/▲			▲/
R/LU105.0078.5.7	.078									Δ/Δ			▲/

- ▲ on stock Δ 4 weeks
- main recommendation
- alternative recommendation
- uncoated grades
- coated grades
- brazed/Cermet

State R or L version

	P	M	K	S	N	H
State R or L version	○	●	●	●	●	●
Carbide grades	□	■	■	■	■	■

Dimensions in inch

Carbide grades

GROOVING (internal) $\geq \text{Ø} .197''$



INSERT Type

U105

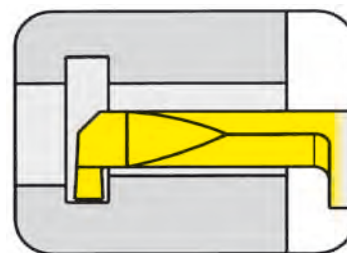

Bore Ø from .197"
 Depth of groove up to .039"

for use with Toolholder

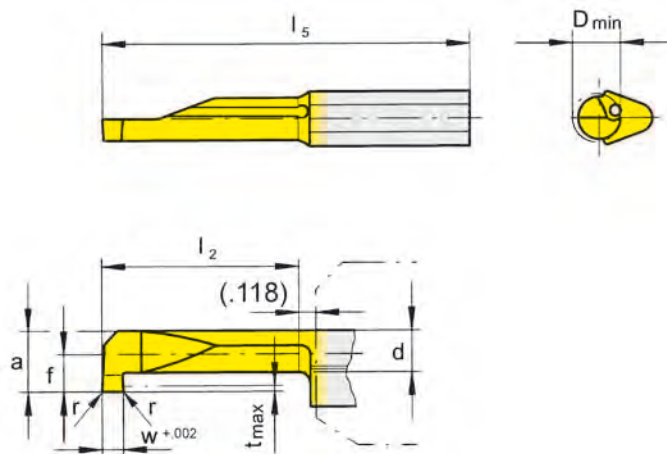

- Type BU105
 B105
 B105C
 B105KM
 BKT
 H105
 HC105
 VDI

R = right hand version shown

L = left hand version

with corner radius

Part number	w	f	a	d	l ₂	l ₅	t _{max}	D _{min}	r	Carbide grades				
										MG12	TN35	TI25	TF45	TH35
R/LU105.4604.1.5	.046										▲/			▲/
R/LU105.6204.1.5	.062	.091	.185	.138	.394	.984	.039	.197	.004		▲/			▲/
R/LU105.7804.1.5	.078										Δ/			Δ/
R/LU105.4604.3.5	.046										▲/▲			▲/
R/LU105.6204.3.5	.062	.091	.185	.138	.787	1.378	.039	.197	.004		▲/			▲/
R/LU105.7804.3.5	.078										▲/			Δ/
R/LU105.4604.5.5	.046													▲/
R/LU105.6204.5.5	.062	.091	.185	.138	1.181	1.772	.039	.197	.004		▲/			▲/
R/LU105.7804.5.5	.078										▲/			Δ/
										P	•			•
										M	•			•
										K	•			•
										S	•			•
										N	•			•
										H				

- ▲ on stock Δ 4 weeks
- main recommendation
- o alternative recommendation
- uncoated grades
- coated grades
- brazed/Cermet

Dimensions in inch
 State R or L version

Carbide grades

GROOVING (internal) $\geq \text{Ø} .236''$



A

INSERT Type

U105

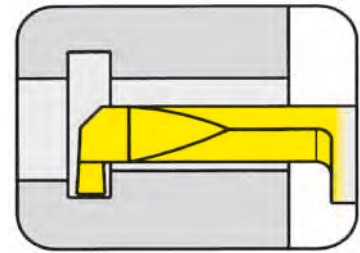

Bore Ø from $.236''$
Depth of groove up to $.071''$

for use with Toolholder

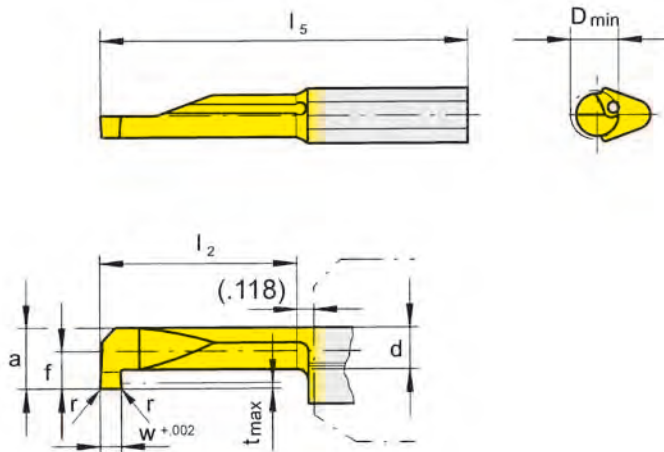

- Type BU105
B105
B105C
B105KM
BKT
H105
HC105
VDI

with corner radius

R = right hand version shown

L = left hand version

Part number	w	f	a	d	l ₂	l ₅	t _{max}	D _{min}	r	Carbide grades				
										MG12	TN35	TI25	TF45	TH35
R/LU105.4604.1.6	.046									▲/▲				▲/
R/LU105.6204.1.6	.062	.130	.224	.146	.394	.984	.071	.236	.004	▲/				▲/
R/LU105.7804.1.6	.078									▲/				▲/
R/LU105.4604.3.6	.046									▲/				▲/
R/LU105.6204.3.6	.062	.130	.224	.146	.787	1.378	.071	.236	.004	▲/				▲/
R/LU105.7804.3.6	.078									▲/Δ				▲/
R/LU105.4604.5.6	.046								.004	▲/				▲/
R/LU105.6204.5.6	.062	.130	.224	.146	1.181	1.772	.071	.236	.004	▲/				▲/
R/LU105.7804.5.6	.078								.004	▲/				▲/
R/LU105.7808.5.6	.078								.008	▲/				▲/
										P	•	•	•	•
										M	•	•	•	•
										K	•	•	•	•
										S	•	•	•	•
										N	•	•	•	•
										H	•	•	•	•

- ▲ on stock Δ 4 weeks
- main recommendation
- o alternative recommendation
- uncoated grades
- coated grades
- brazed/Cermet

Dimensions in inch

State R or L version

Carbide grades

GROOVING (internal) ≥ Ø .268"



INSERT Type

U105

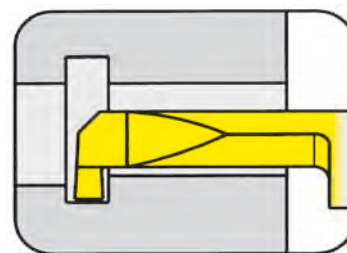

Bore Ø from .268"
Depth of groove up to .098"

for use with Toolholder

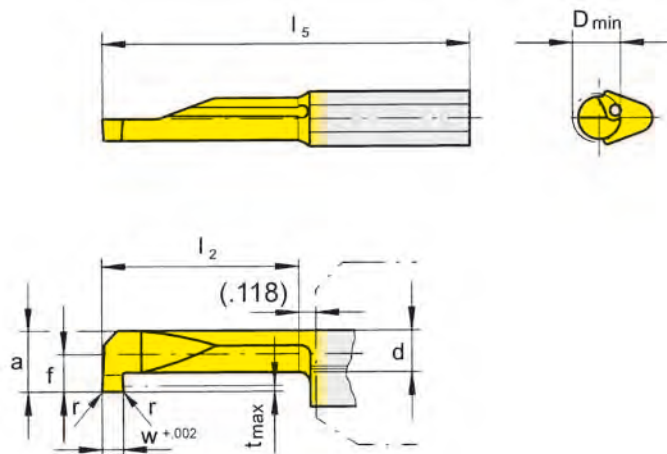

- Type BU105
B105
B105C
B105KM
BKT
H105
HC105
VDI

R = right hand version shown

L = left hand version

with corner radius

Part number	w	f	a	d	l ₂	l ₅	t _{max}	D _{min}	r	Carbide grades			
										MG12	TN35	TI25	TH35
R/LU105.4604.1.7	.046								.004		▲/		▲/
R/LU105.4608.1.7	.046								.008		▲/		▲/
R/LU105.6204.1.7	.062	.157	.252	.146	.394	.984	.098	.268	.004		▲/▲		▲/
R/LU105.6208.1.7	.062								.008		▲/		▲/
R/LU105.4604.2.7	.046								.004		▲/		▲/
R/LU105.4608.2.7	.046								.008		▲/		▲/
R/LU105.6204.2.7	.062	.157	.252	.146	.591	1.181	.098	.268	.004		▲/		▲/
R/LU105.6208.2.7	.062								.008		▲/		▲/
R/LU105.4604.3.7	.046								.004	▲/	▲/▲		▲/
R/LU105.4608.3.7	.046								.008		▲/		▲/
R/LU105.6204.3.7	.062	.157	.252	.146	.787	1.378	.098	.268	.004	▲/	▲/		▲/
R/LU105.6208.3.7	.062								.008		▲/		▲/
R/LU105.4604.4.7	.046								.004		▲/		▲/
R/LU105.4608.4.7	.046								.008		▲/		▲/
R/LU105.6204.4.7	.062	.157	.252	.146	.984	1.575	.098	.268	.004		▲/		▲/
R/LU105.6208.4.7	.062								.008		▲/		▲/
R/LU105.4604.5.7	.046								.004		▲/		▲/
R/LU105.4608.5.7	.046								.008		▲/		▲/
R/LU105.6204.5.7	.062	.157	.252	.146	1.181	1.772	.098	.268	.004		▲/		▲/
R/LU105.6208.5.7	.062								.008		▲/		▲/

- ▲ on stock ▲ 4 weeks
- main recommendation
- alternative recommendation
- uncoated grades
- coated grades
- brazed/Cermet

State R or L version

P	○	●	●
M	●	●	●
K	●	●	●
S	●	●	●
N	●	●	●
H			

Dimensions in inch

Carbide grades

GROOVING (internal) $\geq \text{Ø} .268''$



A

INSERT Type

U105

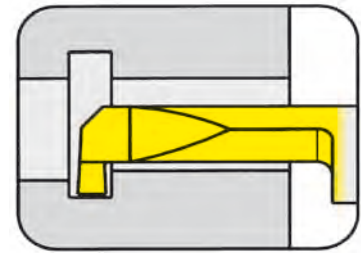

Bore Ø from $.268''$
Depth of groove up to $.098''$

for use with Toolholder

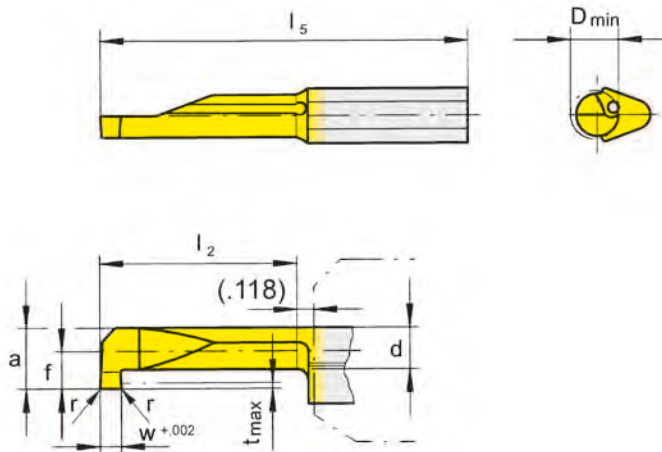

- Type BU105
B105
B105C
B105KM
BKT
H105
HC105
VDI

R = right hand version shown

L = left hand version

with corner radius

Part number	w	f	a	d	l ₂	l ₅	t _{max}	D _{min}	r	Carbide grades				
										MG12	TN35	TI25	TF45	TH35
R/LU105.7804.1.7 R/LU105.7808.1.7	.078	.157	.252	.146	.394	.984	.098	.268	.004 .008		▲/▲			▲/▲
R/LU105.7804.2.7 R/LU105.7808.2.7	.078	.157	.252	.146	.591	1.181	.098	.268	.004 .008		▲/▲			▲/▲
R/LU105.7804.3.7 R/LU105.7808.3.7	.078	.157	.252	.146	.787	1.378	.098	.268	.004 .008		▲/▲			▲/▲
R/LU105.7804.4.7 R/LU105.7808.4.7	.078	.157	.252	.146	.984	1.575	.098	.268	.004 .008		▲/▲			▲/▲
R/LU105.7804.5.7 R/LU105.7808.5.7	.078	.157	.252	.146	1.181	1.772	.098	.268	.004 .008		▲/▲			▲/▲

- ▲ on stock Δ 4 weeks
- main recommendation
- alternative recommendation

- uncoated grades
- coated grades
- brazed/Cermet

Dimensions in inch

State R or L version

P	●	●	●	●
M	●	●	●	●
K	●	●	●	●
S	●	●	●	●
N	●	●	●	●
H				

Carbide grades

GROOVING (internal) $\geq \text{Ø} .157''$



INSERT Type

105

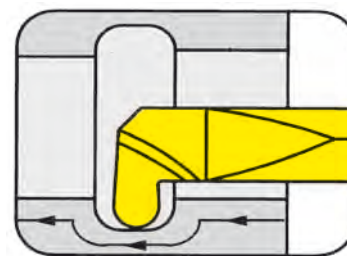

Bore Ø from $.157''$
Full radius r $.020 - .039''$

for use with Toolholder

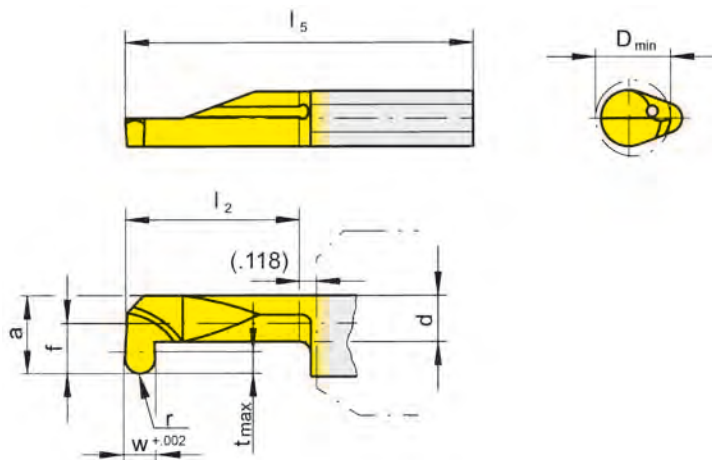

- Type BU105
B105
B105C
B105KM
BKT
H105
HC105
VDI

R = right hand version shown

L = left hand version

Full radius

Part number	w	f	a	d	l ₂	l ₅	t _{max}	D _{min}	r	Carbide grades				
										MG12	TN35	TI25	TF45	TH35
R/L105.0005.2.4	.039	.075	.146	.106	.591	1.181	.031	.157	.020		▲/▲			
R/L105.0005.3.5	.039								.020		▲/▲			
R/L105.0007.3.5	.059	.091	.185	.138	.787	1.378	.039	.197	.030		▲/▲			
R/L105.0010.3.5	.079								.039		▲/▲			
R/L105.0005.4.6	.039								.020		▲/▲			
R/L105.0007.4.6	.059	.130	.224	.146	.984	1.575	.071	.236	.030		▲/▲			
R/L105.0010.4.6	.079								.039		▲/▲			
R/L105.0005.5.7	.039								.020		▲/▲			
R/L105.0007.5.7	.059	.157	.252	.146	1.181	1.772	.098	.268	.030		▲/▲			
R/L105.0010.5.7	.079								.039		▲/▲			

- ▲ on stock Δ 4 weeks
- main recommendation
- alternative recommendation
- uncoated grades
- coated grades
- brazed/Cermet

P	●			
M	●			
K	●			
S	●			
N	●			
H				

Carbide grades

Dimensions in inch

State R or L version

INSERT Type

U105

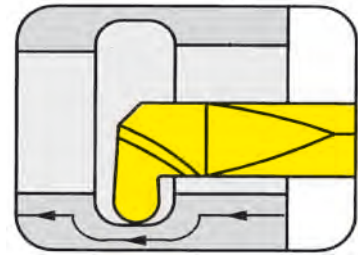

Bore Ø from $.157''$
Full radius r $.023 - .039''$

for use with Toolholder

- Type BU105
B105
B105C
B105KM
BKT
H105
HC105
VDI

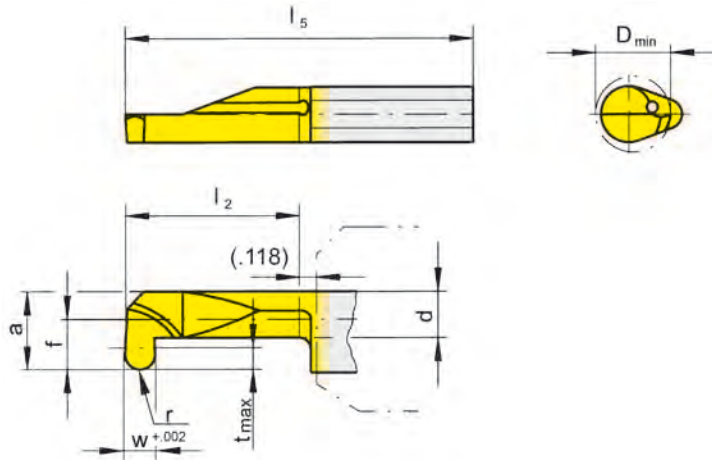

R = right hand version shown

L = left hand version

Full radius

Part number	w	f	a	d	l ₂	l ₅	t _{max}	D _{min}	r	Carbide grades				
										MG12	TN35	TI25	TF45	TH35
R/LU105.2346.2.4	.046	.075	.146	.106	.591	1.181	.031	.157	.023		▲/			▲/
R/LU105.2346.3.5	.046								.023		▲/	Δ/		▲/
R/LU105.3162.3.5	.062	.091	.185	.138	.787	1.378	.039	.197	.031		▲/			▲/
R/LU105.3978.3.5	.078								.039		▲/			▲/
R/LU105.2346.4.6	.046								.023		▲/▲			▲/
R/LU105.3162.4.6	.062	.130	.224	.146	.984	1.575	.071	.236	.031		▲/Δ			▲/
R/LU105.3978.4.6	.078								.039		▲/			▲/
R/LU105.2346.5.7	.046								.023		▲/▲			▲/
R/LU105.3162.5.7	.062	.157	.252	.146	1.181	1.772	.098	.268	.031		▲/▲			▲/
R/LU105.3978.5.7	.078								.039		▲/			▲/

- ▲ on stock Δ 4 weeks
- main recommendation
- alternative recommendation
- uncoated grades
- coated grades
- brazed/Cermet

	MG12	TN35	TI25	TF45	TH35
P	●	●	●	●	●
M	●	●	●	●	●
K	●	●	●	●	●
S	●	●	●	●	●
N	●	●	●	●	●
H	●	●	●	●	●

Carbide grades

Dimensions in inch

State R or L version

THREADING (internal) Partial profile



INSERT Type

105

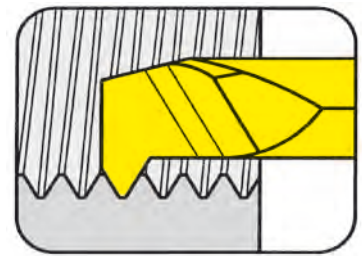

Bore Ø from Pitch .118" (3.0 mm)
P 0.25 mm

for use with Toolholder

- Type BU105
B105
B105C
B105KM
BKT
H105
HC105
VDI

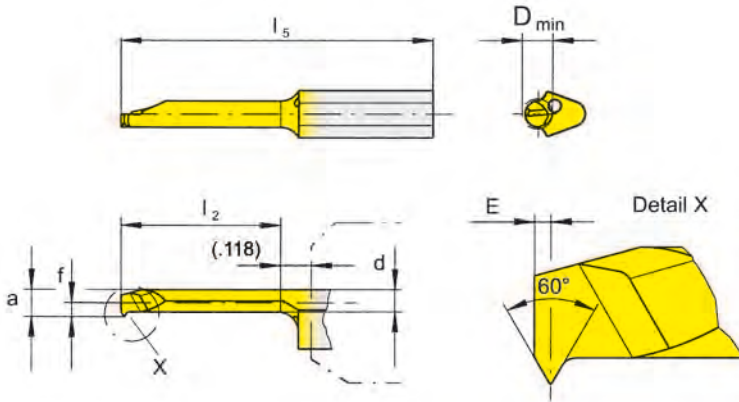

R = right hand version shown

L = left hand version

Metric ISO thread

Part number	P	E	f	a	d	l ₂	l ₅	D _{min}	Carbide grades					
									MG12	TN35	TI25	TF45	TH35	
R/L105.0102.2.3	0.25	0.3	1.4	2.7	2.2	15	30	3		▲/△				
									P	•				
									M	•				
									K	•				
									S	•				
									N	•				
									H					

- ▲ on stock Δ 4 weeks
- main recommendation
- o alternative recommendation
- uncoated grades
- coated grades
- brazed/Cermet

Dimensions in mm

State R or L version

INSERT Type

105

Bore Ø from Pitch .118" (3.0 mm)
P 0.35 mm

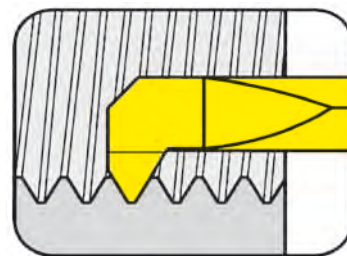

for use with Toolholder

- Type BU105
B105
B105C
B105KM
BKT
H105
HC105
VDI

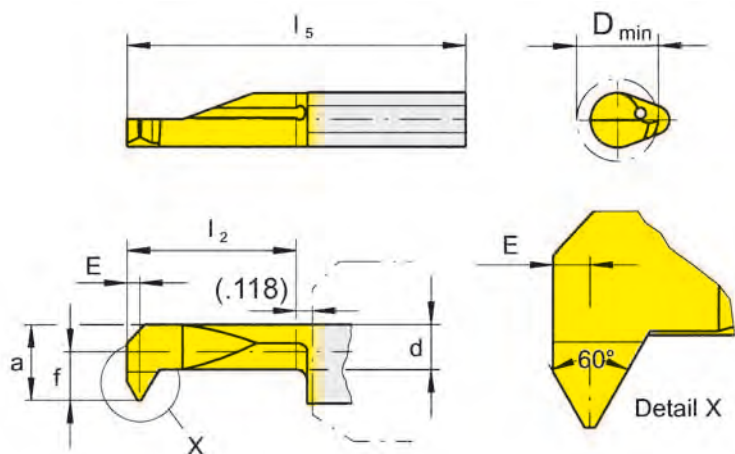

R = right hand version shown

L = left hand version

Metric ISO thread

Part number	P	E	f	a	d	l ₂	l ₅	D _{min}	Carbide grades					
									MG12	TN35	TI25	TF45	TH35	
R/L105.0203.1.3	0.35	0.3	1.4	2.7	2.1	10	25	3		▲/▲				
R/L105.0203.2.5	0.35	0.3	2.3	4.7	3.5	15	30	5		▲/▲				
									P	•				
									M	•				
									K	•				
									S	•				
									N	•				
									H					

Carbide grades

- ▲ on stock Δ 4 weeks
- main recommendation
- o alternative recommendation
- uncoated grades
- coated grades
- brazed/Cermet

Dimensions in mm

State R or L version

INSERT Type

105

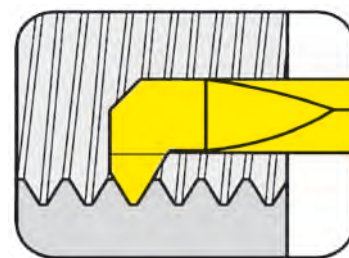

Bore Ø from Pitch .118" (3.0 mm)
P 0.50 mm

for use with Toolholder

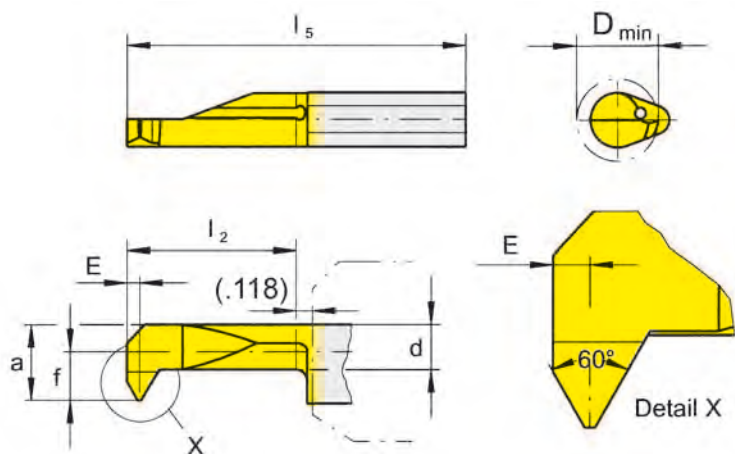

- Type
- BU105
 - B105
 - B105C
 - B105KM
 - BKT
 - H105
 - HC105
 - VDI

R = right hand version shown

L = left hand version

Metric ISO thread

Part number	P	E	f	a	d	l ₂	l ₅	D _{min}	Carbide grades					
									MG12	TN35	TI25	TF45	TH35	
R/L105.0205.2.3	0.5	0.35	1.4	2.7	2.1	15	30	3		▲/▲				
R/L105.0205.2.4	0.5	0.35	1.9	3.7	2.7	15	30	4		▲/▲				▲/▲
R/L105.0205.3.4										Δ/				
R/L105.0205.2.5	0.5	0.35	2.3	4.7	3.5	20	35	5	▲/▲	▲/▲				▲/▲
R/L105.0205.3.5										Δ/Δ				
R/L105.0205.4.5										▲/				
R/L105.0205.3.6	0.5	0.35	3.3	5.7	4.8	20	35	6		▲/				

- ▲ on stock Δ 4 weeks
- main recommendation
- alternative recommendation
- uncoated grades
- coated grades
- brazed/Cermet

Dimensions in mm

State R or L version

	P	M	K	S	N	H
MG12	○	●	●	●	●	●
TN35	●	●	●	●	●	●
TI25	●	●	●	●	●	●
TF45	●	●	●	●	●	●
TH35	●	●	●	●	●	●

Carbide grades

THREADING (internal) Partial profile



A

INSERT Type

105

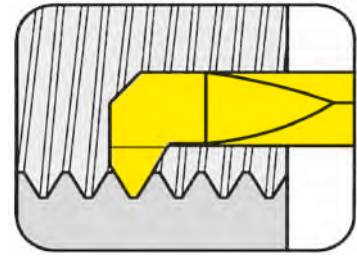

Bore Ø from Pitch

.118" (3.0 mm)
P 0.50 - 0.75 mm

for use with Toolholder

Type BU105
B105
B105C
B105KM
BKT
H105
HC105
VDI

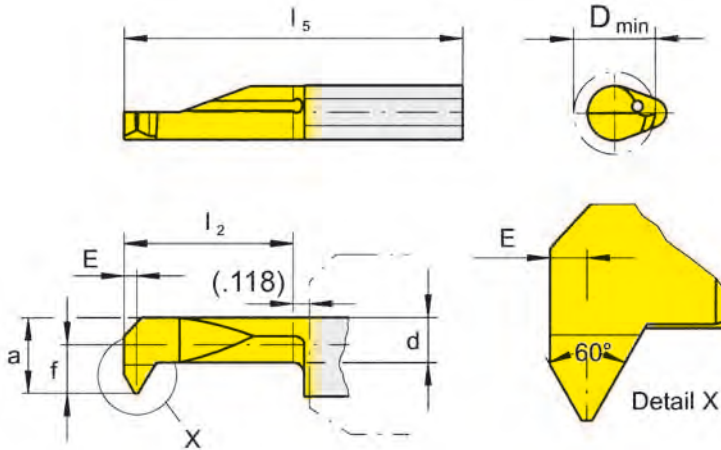

R = right hand version shown

L = left hand version

Metric ISO thread

Part number	P	P _{max}	E	f	a	d	l ₂	l ₅	D _{min}	Carbide grades				
										MG12	TN35	TI25	TF45	TH35
R/L105.0407.2.3	0.5	0.75	0.45	1.4	2.7	2.0	15	30	3		▲/			
R/L105.0407.1.4	0.5	0.75	0.45	1.9	3.7	2.7	10	25	4		▲/▲			
R/L105.0407.2.4							15	30			▲/▲			
R/L105.0407.3.4							20	35			▲/▲			
R/L105.0407.2.5	0.5	0.75	0.45	2.3	4.7	3.5	15	30	5		▲/▲		▲/▲	
R/L105.0407.3.5							20	35			▲/▲			
R/L105.0407.4.5							25	40			▲/▲			
R/L105.0407.3.6	0.5	0.75	0.45	3.3	5.7	4.7	20	35	6		▲/			

- ▲ on stock Δ 4 weeks
- main recommendation
- alternative recommendation
- uncoated grades
- coated grades
- brazed/Cermet

Dimensions in mm

State R or L version

Carbide grades

THREADING (internal) Partial profile



INSERT Type

105

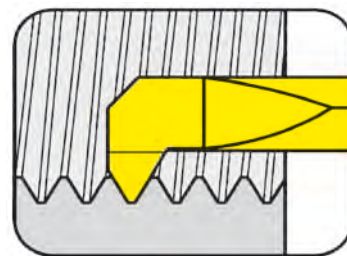

Bore Ø from Pitch .189" (4.8 mm)
P 1.00 - 1.50 mm

for use with Toolholder

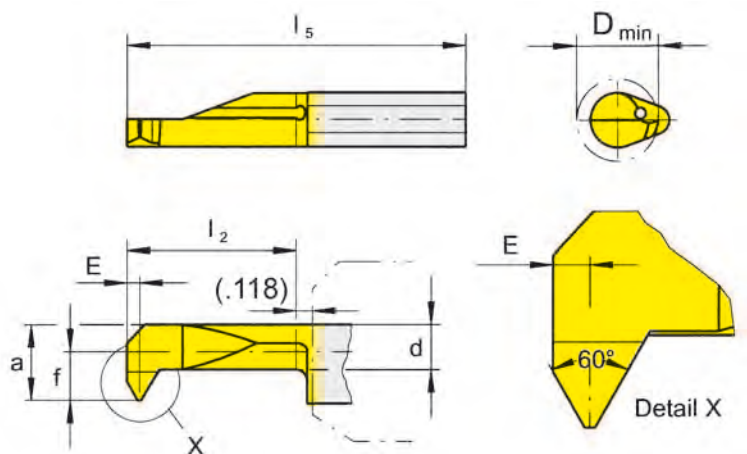

- Type BU105
B105
B105C
B105KM
BKT
H105
HC105
VDI

R = right hand version shown

L = left hand version

Metric ISO thread

Part number	P	E	f	a	d	l ₂	l ₅	D _{min}	MG12	TN35	TI25	TF45	TH35
									▲/△	▲/△			▲/△
R/L105.0510.2.5						15	30	4.8	▲/△	▲/△			▲/△
R/L105.0510.3.5	1.00	0.55	2.1	4.5	3.5	20	35			▲/△			
R/L105.0510.4.5						25	40			▲/△			
R/L105.0510.2.6	1.00	0.55				15	30	6.0		▲/△			▲/△
R/L105.0510.3.6	1.00	0.55				20	35			▲/△			
R/L105.0510.4.6	1.00	0.55				25	40			▲/△			
R/L105.0612.2.6	1.25	0.65	3.3	5.7	3.7	15	30	7.0	△/△	▲/△			▲/△
R/L105.0612.3.6	1.25	0.65				20	35			▲/△			
R/L105.0612.4.6	1.25	0.65				25	40			▲/△			
R/L105.0815.2.7						15	30	7.0		▲/△			▲/△
R/L105.0815.3.7	1.50	0.75	4.0	6.4	3.7	20	35			▲/△			
R/L105.0815.4.7						25	40			▲/△			
									P	o	•	•	•
									M	•	•	•	•
									K	•	•	•	•
									S	•	•	•	•
									N	•	•	•	•
									H				

- ▲ on stock △ 4 weeks
- main recommendation
- o alternative recommendation
- uncoated grades
- coated grades
- brazed/Cermet

Dimensions in mm

State R or L version

Carbide grades

THREADING (internal) Partial profile



A

INSERT Type

105

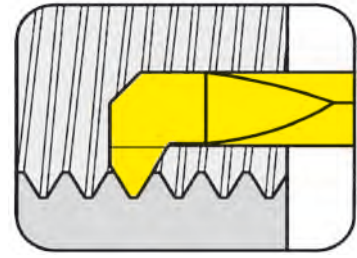

Bore Ø from
Threads per inch

.157"
16 - 40

for use with Toolholder

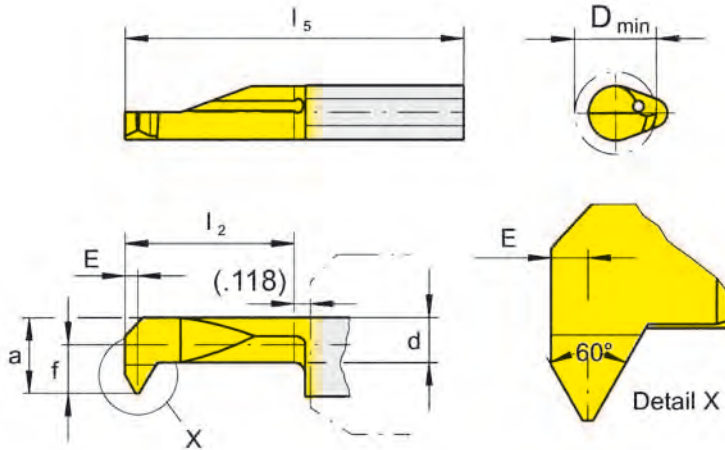

Type BU105
B105
B105C
B105KM
BKT
H105
HC105
VDI

R = right hand version shown

L = left hand version

Thread UN

Part number	Threads per Inch	E	f	a	d	I ₂	I ₅	D _{min}	Carbide grades					
									MG12	TN35	TI25	TF45	TH35	
R/L105.3240.2.4	32 - 40	.018	.075	.146	.106	.591	1.181	.157		▲/▲	▲/	▲/▲		
R/L105.2428.2.5	24 - 28	.022	.091	.185	.138	.591	1.181	.197		▲/▲	▲/			
R/L105.3240.2.5	32 - 40	.018	.091	.185	.138	.591	1.181	.197		▲/▲	▲/	▲/▲		
R/L105.1620.2.5	16 - 20	.028	.130	.224	.146	.591	1.181	.197					▲/▲	
R/L105.1620.3.5	16 - 20	.028	.130	.224	.146	.787	1.378	.197					▲/▲	
R/L105.1620.2.6	16 - 20	.028	.130	.224	.146	.591	1.181	.236		▲/▲				
R/L105.1620.3.6	16 - 20	.028	.130	.224	.146	.787	1.378	.236		▲/				
R/L105.1620.4.6	16 - 20	.028	.130	.224	.146	.984	1.575	.236		▲/				
R/L105.2428.2.6	24 - 28	.022	.130	.224	.146	.591	1.181	.236		▲/▲	▲/			
R/L105.2428.3.6	24 - 28	.022	.130	.224	.146	.787	1.378	.236		▲/				
R/L105.2428.4.6	24 - 28	.022	.130	.224	.146	.984	1.575	.236		▲/▲				

- ▲ on stock Δ 4 weeks
- main recommendation
- alternative recommendation
- uncoated grades
- coated grades
- brazed/Cermet

Dimensions in inch

State R or L version

	P	M	K	S	N	H
MG12	●	●	●	●	●	●
TN35	●	●	●	●	●	●
TI25	●	●	●	●	●	●
TF45	●	●	●	●	●	●
TH35	●	●	●	●	●	●

Carbide grades

INSERT Type

105

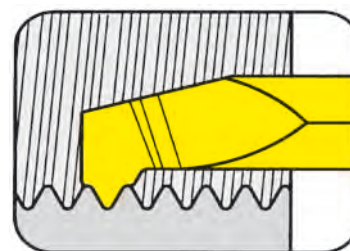

Bore Ø from Pitch .094" (2.4 mm)
P 0.50 - 1.25 mm

for use with Toolholder

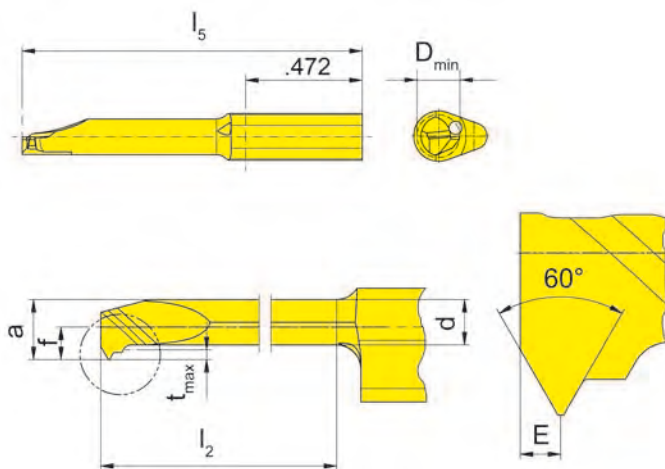

- Type BU105
B105
B105C
B105KM
BKT
H105
HC105
VDI

R = right hand version shown

L = left hand version

Metric ISO thread

Part number	P	E	f	a	d	l ₂	l ₅	D _{min}	Carbide grades				
									MG12	TN35	TI25	TF45	TH35
R/L105.VPM3.2.3 R/L105.VPM3.4.3	0.50	0.3	1.4	2.2	1.65	9 12	25 35	2.4					▲/▲
												▲/▲	
R/L105.VPM4.2.4 R/L105.VPM4.3.4	0.70	0.4	1.5	2.9	2.10	15 20	30 35	3.2					▲/▲
												▲/▲	
R/L105.VPM5.2.5 R/L105.VPM5.4.5	0.80	0.5	2.0	3.7	2.80	15 25	30 40	4.1					▲/▲
												▲/▲	
R/L105.VPM6.3.6 R/L105.VPM6.4.6 R/L105.VPM6.5.6	1.00	0.5	2.4	4.5	3.40	20 25 30	35 40 45	4.9					▲/▲
												Δ/Δ	
												▲/▲	
R/L105.VPM8.3.8 R/L105.VPM8.5.8	1.25	0.7	3.8	6.2	4.70	20 30	35 45	6.6					▲/▲
												▲/▲	

- ▲ on stock Δ 4 weeks
- main recommendation
- alternative recommendation
- uncoated grades
- coated grades
- brazed/Cermet

P				●
M				●
K				●
S				●
N				●
H				

Carbide grades

Dimensions in mm

State R or L version

THREADING (internal) Partial profile



A

INSERT Type

105

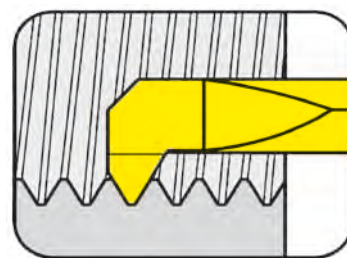

Bore Ø from .236"
Threads per inch 18 - 27

for use with Toolholder

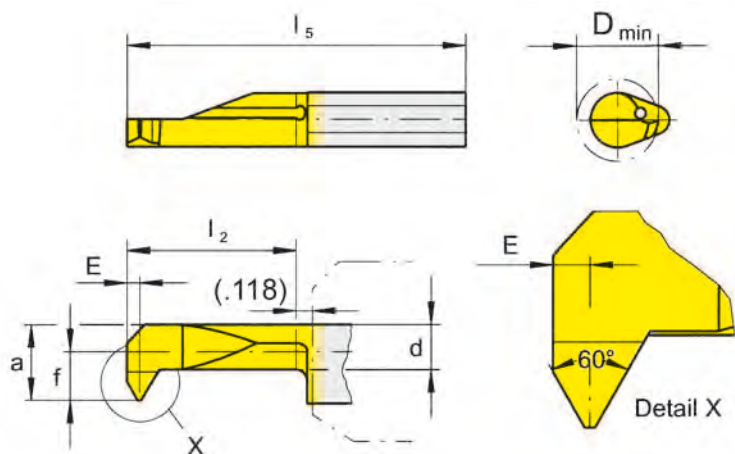

- Type
- BU105
 - B105
 - B105C
 - B105KM
 - BKT
 - H105
 - HC105
 - VDI

R = right hand version shown

L = left hand version

Thread NPT

Part number	Threads per Inch	E	f	a	d	I ₂	I ₅	D _{min}	Carbide grades					
									MG12	TN35	TI25	TF45	TH35	
R/L105.NP18.2.6	18	.039				.591	1.181	.236		▲/▲				
R/L105.NP18.3.6	18	.039				.787	1.378			Δ/Δ				
R/L105.NP18.4.6	18	.039				.984	1.575			Δ/Δ				
R/L105.NP27.2.6	27	.031	.130	.224	.146	.591	1.181			▲/▲				
R/L105.NP27.3.6	27	.031				.787	1.378			Δ/Δ				
R/L105.NP27.4.6	27	.031				.984	1.575			Δ/Δ				
▲ on stock Δ 4 weeks ● main recommendation ○ alternative recommendation □ uncoated grades ■ coated grades ■ brazed/Cermet										P	•			
										M	•			
										K	•			
										S	•			
										N	•			
										H				

Dimensions in inch

Carbide grades

State R or L version

THREADING (internal) Full profile



INSERT Type

105

Whitworth thread

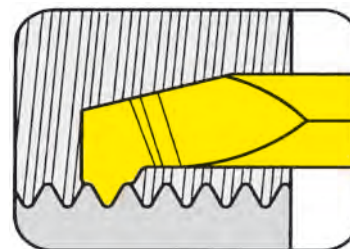

Bore Ø from .157"
Threads per inch 19 - 28

for use with Toolholder

- Type BU105
B105
B105C
B105KM
BKT
H105
HC105
VDI

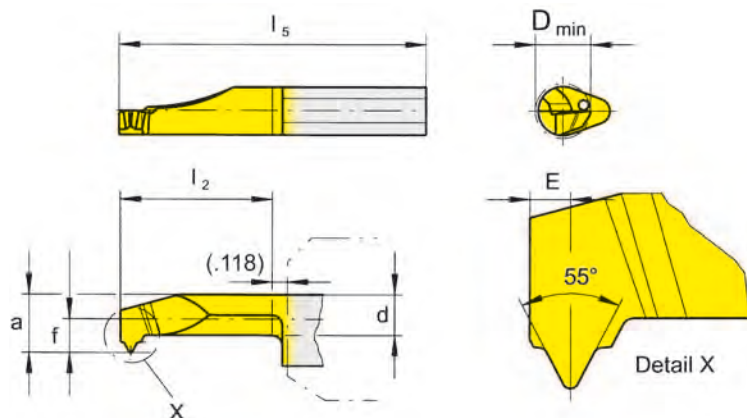

R = right hand version shown

Thread BSW/BSF

Part number	Threads per Inch	E	f	a	d	l ₂	l ₅	D _{min}	Carbide grades					
									MG12	TN35	TI25	TF45	TH35	
R105.5520.2.4	20	.039	.075	.146	.098	.591	1.181	.157		Δ				
R105.5519.3.6	19	.039								▲				
R105.5522.3.6	22	.039								Δ				
R105.5524.3.6	24	.031	.130	.224	.146	.787	1.378	.236		Δ				
R105.5526.3.6	26	.031								Δ				
R105.5528.3.6	28	.031								Δ				
										P	•			
										M	•			
										K	•			
										S	•			
										N	•			
										H				

- ▲ on stock Δ 4 weeks
- main recommendation
- o alternative recommendation
- uncoated grades
- coated grades
- brazed/Cermet

Dimensions in inch

Carbide grades

THREADING (internal) Full profile



INSERT Type

105

Whitworth thread

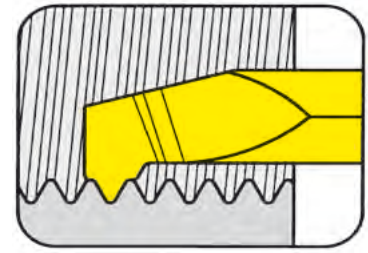

Bore Ø from .197"
Threads per inch 19 - 28

for use with Toolholder

Type BU105
B105
B105C
B105KM
BKT
H105
HC105
VDI

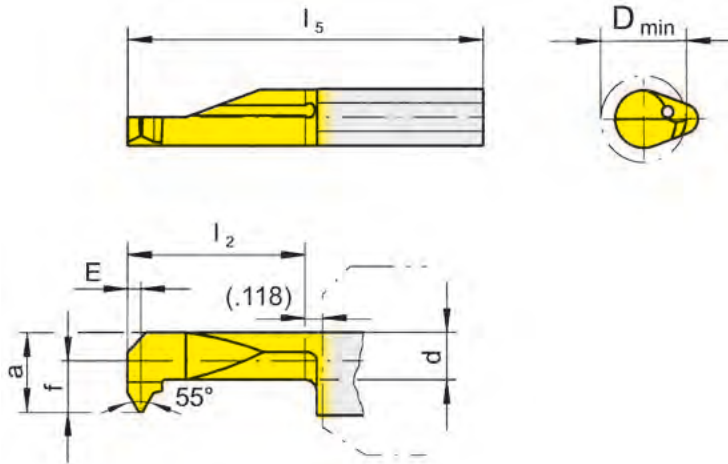

R = right hand version shown

L = left hand version

Thread BSW/BSF

Part number	Threads per Inch	E	f	a	d	l ₂	l ₅	D _{min}	Carbide grades					
									MG12	TN35	TI25	TF45	TH35	
R/L105.5524.2.5	24									▲/▲				
R/L105.5526.2.5	26	.031	.091	.185	.138	.591	1.181	.197		▲/▲				
R/L105.5528.2.5	28									▲/▲				
R/L105.5524.2.6	24									▲/▲				
R/L105.5526.2.6	26	.031	.130	.224	.146	.591	1.181	.236		▲/▲				
R/L105.5528.2.6	28									▲/▲				
R/L105.5519.2.6	19									▲/▲				
R/L105.5520.2.6	20	.039	.130	.224	.146	.591	1.181	.236		▲/▲				
R/L105.5522.2.6	22									▲/▲				
									P	•				
									M	•				
									K	•				
									S	•				
									N	•				
									H					

Dimensions in inch

State R or L version

- ▲ on stock Δ 4 weeks
- main recommendation
- o alternative recommendation
- uncoated grades
- coated grades
- brazed/Cermet

P	•			
M	•			
K	•			
S	•			
N	•			
H				

Carbide grades

INSERT Type

U105

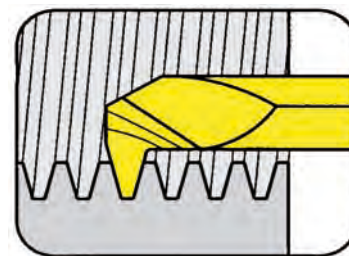

Bore Ø from .197"
Threads per inch 10 - 16

for use with Toolholder

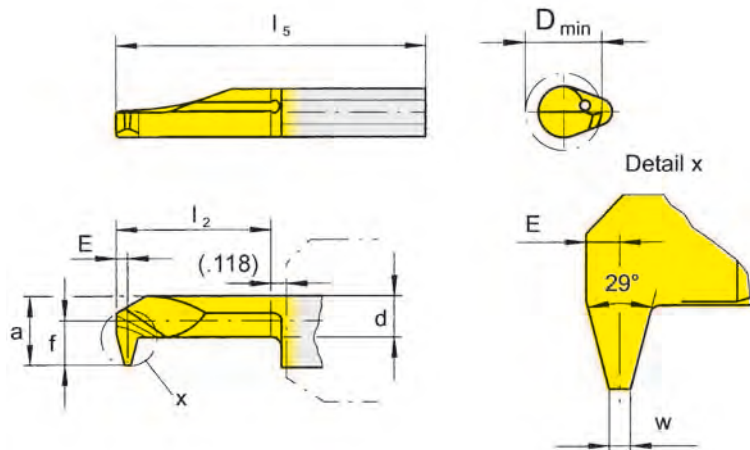

- Type BU105
B105
B105C
B105KM
BKT
H105
HC105
VDI

ACME / Stub ACME
thread

R = right hand version shown

L = left hand version

Part number	Threads per Inch	E	f	a	d	I ₂	I ₅	D _{min}	Carbide grades					
									MG12	TN35	TI25	TF45	TH35	
R/LU105.AC16.2.5 R/LU105.AC16.4.5	16	.028	.079	.173	.122	.591 .984	1.181 1.575	.197		▲/	▲/			▲/
R/LU105.AC14.2.6 R/LU105.AC14.4.6	14	.035	.130	.224	.169	.591 .984	1.181 1.575	.236		▲/				▲/
R/LU105.AC12.3.7 R/LU105.AC12.5.7	12	.039	.157	.252	.189	.787 1.181	1.378 1.772	.276		▲/				▲/
R/LU105.AC10.3.7	10	.039	.157	.252	.173	.787	1.378	.276		▲/				▲/

- ▲ on stock Δ 4 weeks
- main recommendation
- alternative recommendation
- uncoated grades
- coated grades
- brazed/Cermet

Dimensions in inch

State R or L version

P	●	●	●	●
M	●	●	●	●
K	●	●	●	●
S	●	●	●	●
N	●	●	●	●
H				

Carbide grades

INSERT Type

U105

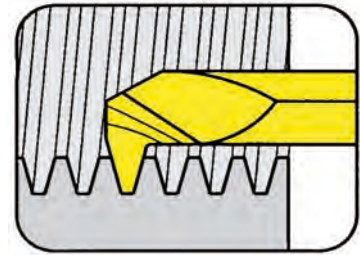

Bore Ø from .197"
Threads per inch 10 - 16

for use with Toolholder

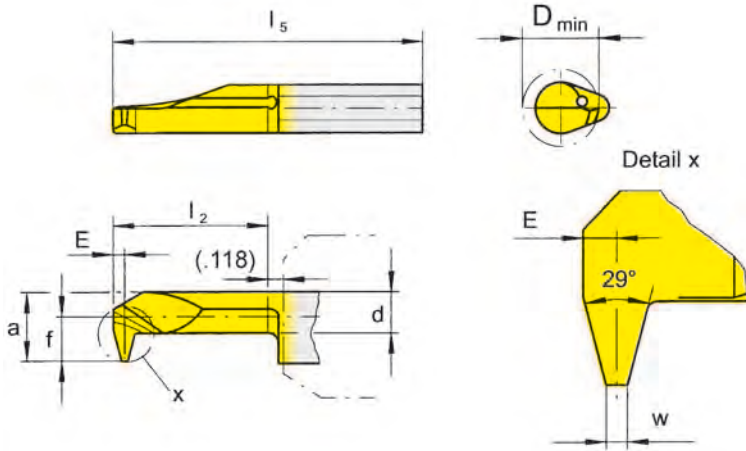

- Type
- BU105
 - B105
 - B105C
 - B105KM
 - BKT
 - H105
 - HC105
 - VDI

ACME / Stub ACME
thread

R = right hand version shown

L = left hand version

Part number	Threads per Inch	E	f	a	d	I ₂	I ₅	D _{min}	Carbide grades				
									MG12	TN35	TI25	TF45	TH35
R/LU105.SA16.2.5 R/LU105.SA16.4.5	16	.028	.091	.185	.142	.591 .984	1.181 1.575	.197		▲/			▲/
R/LU105.SA14.2.6 R/LU105.SA14.4.6	14	.035	.131	.224	.177	.591 .984	1.181 1.575	.236		▲/			▲/
R/LU105.SA12.3.7 R/LU105.SA12.5.7	12	.039	.157	.252	.201	.787 1.181	1.378 1.772	.276		▲/	Δ/		▲/
R/LU105.SA10.3.7	10	.039	.157	.252	.193	.787	1.378	.276		Δ/			▲/
▲ on stock Δ 4 weeks ● main recommendation ○ alternative recommendation □ uncoated grades ■ coated grades ■ brazed/Cermet									P	●	●	●	●
									M	●	●	●	●
									K	●	●	●	●
									S	●	●	●	●
									N	●	●	●	●
									H				

Dimensions in inch

State R or L version

Carbide grades

INSERT Type

105

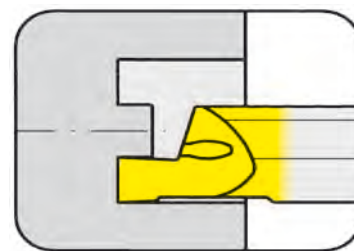

from outer groove \varnothing	.197"
Depth of groove up to	.197"
Width of groove up to	.079"

for use with Toolholder

- Type BU105
 B105
 B105C
 B105KM
 BKT
 H105
 HC105
 VDI

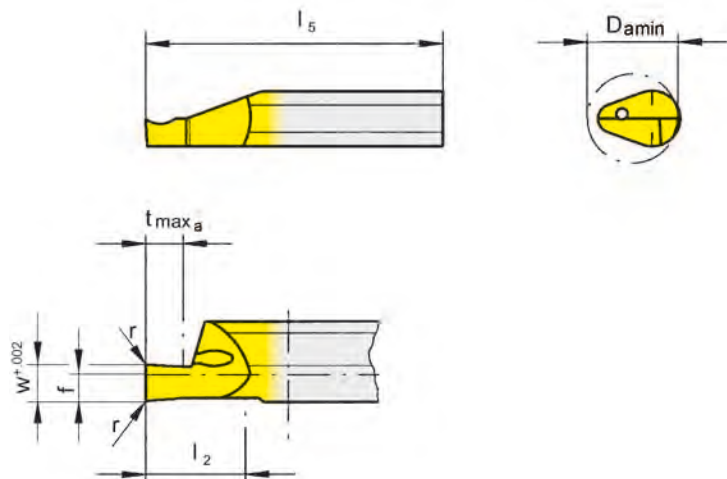

R = right hand version shown

L = left hand version

Part number	w	f	l ₂	l ₅	t _{max a}	D _{a min}	r	Carbide grades				
								MG12	TN35	TI25	TF45	TH35
R/L105.0510.1.8	.039				.079			▲/△		▲/▲		
R/L105.0515.1.8	.059	.079	.394	.984	.118	.197	.002	▲/△		▲/▲		
R/L105.0520.1.8	.079				.197			▲/△		▲/▲		
R/L105.0510.2.8	.039				.079			△/△		▲/▲		
R/L105.0515.2.8	.059	.079	.591	1.378	.118	.197	.002	△/△		▲/▲		
R/L105.0520.2.8	.079				.197			▲/▲		▲/▲		
								P	○	●		
								M	●	●		
								K	●	●		
								S	●	●		
								N	●	●		
								H				

- ▲ on stock △ 4 weeks
- main recommendation
- alternative recommendation
- uncoated grades
- coated grades
- brazed/Cermet

Dimensions in inch
 State R or L version

Carbide grades

INSERT Type

105

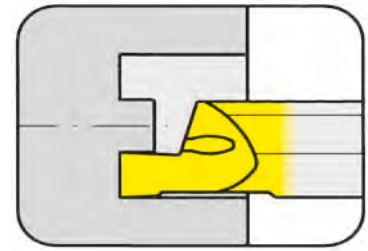

from outer groove \varnothing	.236"
Depth of groove up to	.197"
Width of groove up to	.079"

for use with Toolholder

- Type
- BU105
 - B105
 - B105C
 - B105KM
 - BKT
 - H105
 - HC105
 - VDI

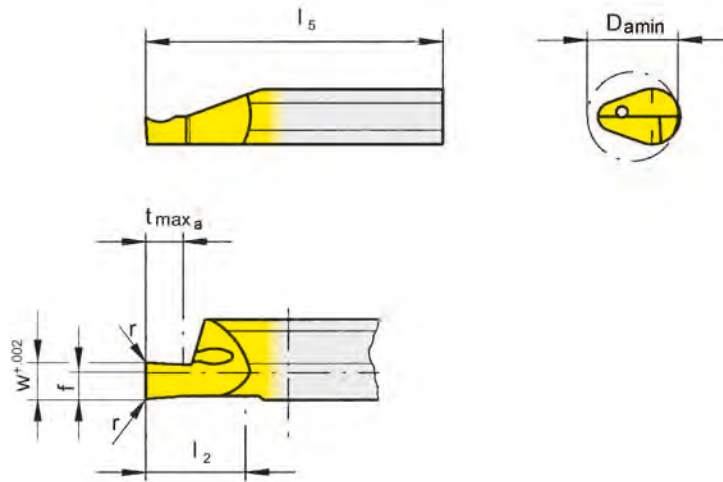

R = right hand version shown

L = left hand version

Part number	w	f	l ₂	l ₅	t _{max a}	D _{a min}	r	MG12	TN35	TI25	TF45	TH35
R/L105.0610.1.8	.039				.079			▲/▲		▲/▲		
R/L105.0615.1.8	.059	.079	.394	.984	.118	.236	.002	Δ/Δ		▲/▲		
R/L105.0620.1.8	.079				.197			▲/Δ		▲/▲		
R/L105.0610.2.8	.039				.079			Δ/Δ		Δ/▲		
R/L105.0615.2.8	.059	.079	.591	1.378	.118	.236	.002	Δ/		▲/Δ		
R/L105.0620.2.8	.079				.197			Δ/Δ		▲/▲		
								P	○	●		
								M	●	●		
								K	●	●		
								S	●	●		
								N	●	●		
								H				

- ▲ on stock Δ 4 weeks
- main recommendation
- alternative recommendation
- uncoated grades
- coated grades
- brazed/Cermet

Dimensions in inch

State R or L version

Carbide grades

INSERT Type

105

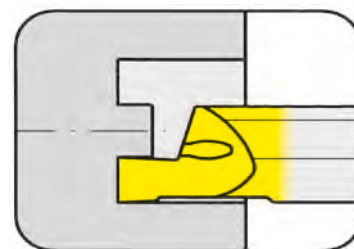

from outer groove \varnothing	.315"
Depth of groove up to	.236"
Width of groove up to	.118"

for use with Toolholder

- Type BU105
 B105
 B105C
 B105KM
 BKT
 H105
 HC105
 VDI

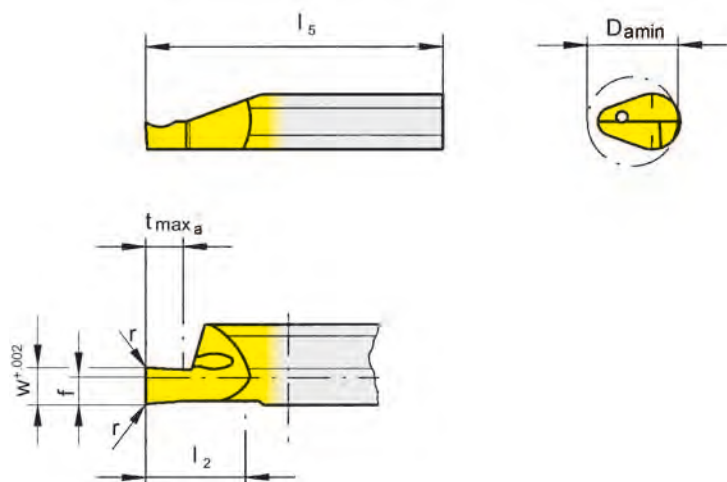

R = right hand version shown

L = left hand version

Part number	w	f	l ₂	l ₅	t _{max a}	D _{a min}	r	Carbide grades						
								MG12	TN35	TI25	TF45	TH35		
R/L105.0810.1.8	.039				.079					▲▲				
R/L105.0815.1.8	.059				.118					▲▲				
R/L105.0820.1.8	.079	.079	.394	.984	.157	.315	.006			▲▲				
R/L105.0825.1.8	.098				.197					▲▲				
R/L105.0830.1.8	.118				.236					▲▲				
R/L105.0810.2.8	.039				.079					▲▲				
R/L105.0815.2.8	.059				.118					▲▲				
R/L105.0820.2.8	.079	.079	.591	1.378	.157	.315	.006			▲▲				
R/L105.0825.2.8	.098				.197					▲▲				
R/L105.0830.2.8	.118				.236					▲▲				
								P		●				
								M		●				
								K		●				
								S		●				
								N		●				
								H						

- ▲ on stock Δ 4 weeks
- main recommendation
- alternative recommendation
- uncoated grades
- coated grades
- brazed/Cermet

Dimensions in inch

Carbide grades

State R or L version

INSERT Type

U105

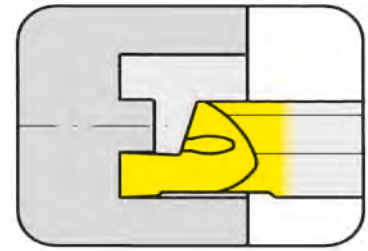

from outer groove Ø	.315"
Depth of groove up to	.236"
Width of groove up to	.125"

for use with Toolholder

- Type BU105
 B105
 B105C
 B105KM
 BKT
 H105
 HC105
 VDI

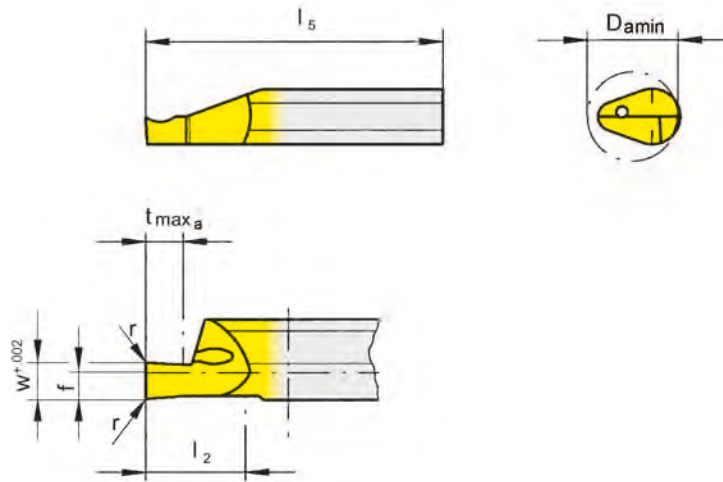

R = right hand version shown

L = left hand version

Part number	w	f	l ₂	l ₅	t _{max a}	D _{a min}	r	Carbide grades				
								MG12	TN35	TI25	TF45	TH35
R/LU105.0846.1.8	.046				.098					▲▲		▲/
R/LU105.0862.1.8	.062				.118					▲▲		▲/
R/LU105.0878.1.8	.078	.079	.394	.984	.157	.315	.006			▲▲		▲/
R/LU105.0894.1.8	.094				.197					▲▲		▲/
R/LU105.0812.1.8	.125				.236					▲▲		▲/
R/LU105.0846.2.8	.046				.098					▲▲		▲/
R/LU105.0862.2.8	.062				.118					▲▲		▲/
R/LU105.0878.2.8	.078	.079	.591	1.378	.157	.315	.006			▲▲		▲/
R/LU105.0894.2.8	.094				.197					▲▲		▲/
R/LU105.0812.2.8	.125				.236					▲▲		▲/
▲ on stock Δ 4 weeks ● main recommendation ○ alternative recommendation □ uncoated grades ■ coated grades ■ brazed/Cermet								P		●		●
								M		●		●
								K		●		●
								S		●		●
								N		●		●
								H				

Dimensions in inch

Carbide grades

State R or L version

INSERT Type

U105

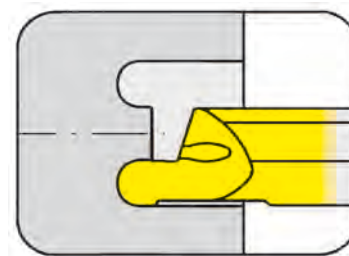

from outer groove Ø .315"
 Depth of groove up to .236"
 Width of groove up to .125"

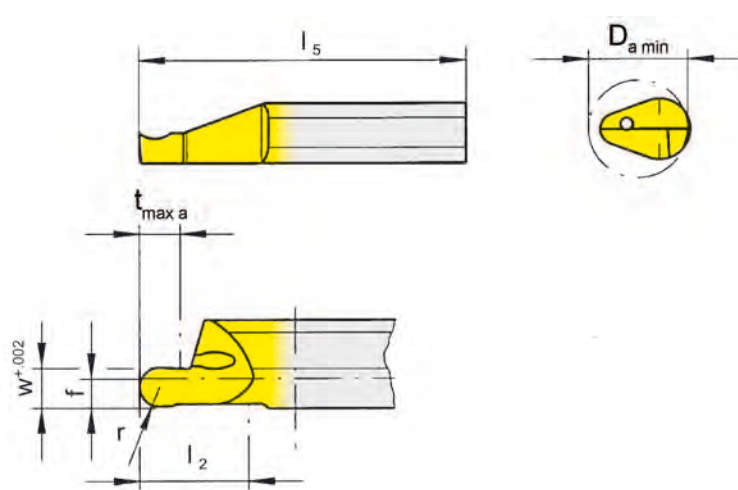

for use with Toolholder

- Type BU105
 B105
 B105C
 B105KM
 BKT
 H105
 HC105
 VDI

Full radius

R = right hand version shown

L = left hand version

Part number	w	f	l ₂	l ₅	t _{max a}	D _{a min}	r	Carbide grades				
								MG12	TN35	TI25	TF45	TH35
R/LU105.FF46.1.8	.046				.098		.023			▲▲		▲/
R/LU105.FF62.1.8	.062				.118		.031			▲▲		▲/
R/LU105.FF78.1.8	.078	.079	.394	.984	.157	.315	.039			▲▲		▲/
R/LU105.FF94.1.8	.094				.197		.047			▲/		▲/
R/LU105.FF12.1.8	.125				.236		.062			▲▲		▲/
R/LU105.FF46.2.8	.046				.098		.023			▲/		▲/
R/LU105.FF62.2.8	.062				.118		.031			▲/		▲/
R/LU105.FF78.2.8	.078	.079	.591	1.378	.157	.315	.039			▲/		▲/
R/LU105.FF94.2.8	.094				.197		.047			▲/		▲/
R/LU105.FF12.2.8	.125				.236		.062			▲/		▲/
								P		•		•
								M		•		•
								K		•		•
								S		•		•
								N		•		•
								H				

- ▲ on stock Δ 4 weeks
- main recommendation
- o alternative recommendation
- uncoated grades
- coated grades
- brazed/Cermet

Dimensions in inch

State R or L version

Carbide grades

INSERT Type

105

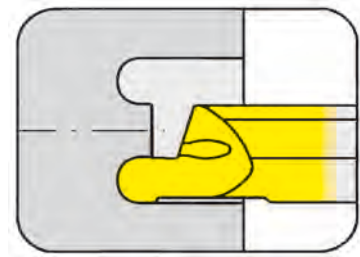

from outer groove \varnothing .315"
 Depth of groove up to .236"
 Width of groove up to .118"

for use with Toolholder

- Type BU105
 B105
 B105C
 B105KM
 BKT
 H105
 HC105
 VDI

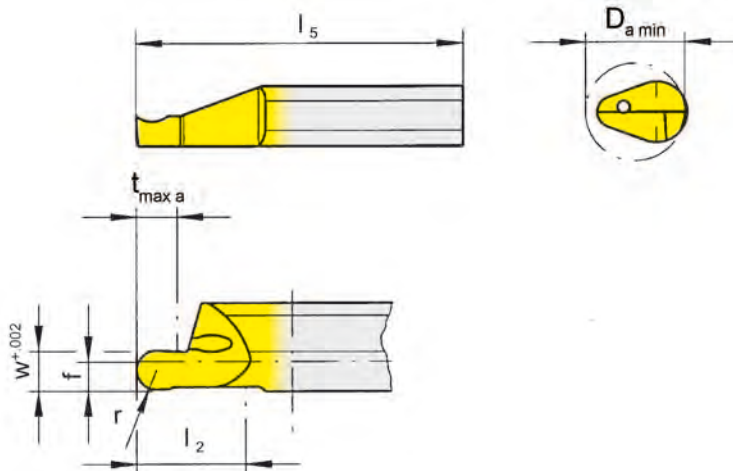

R = right hand version shown

L = left hand version

Full radius

Part number	w	f	l ₂	l ₅	t _{max a}	D _{a min}	r	Carbide grades				
								MG12	TN35	TI25	TF45	TH35
R/L105.8V10.1.8	.039				.079		.020			▲▲		
R/L105.8V16.1.8	.063				.118		.031			▲▲		
R/L105.8V20.1.8	.079	.079	.394	.984	.157	.315	.039			▲▲		
R/L105.8V25.1.8	.098				.197		.049			▲▲		
R/L105.8V30.1.8	.118				.236		.059			▲▲		
R/L105.8V10.2.8	.039				.079		.020			▲▲		
R/L105.8V16.2.8	.063				.118		.031			▲▲		
R/L105.8V20.2.8	.079	.079	.591	1.378	.157	.315	.039			▲▲		
R/L105.8V25.2.8	.098				.197		.049			▲/Δ		
R/L105.8V30.2.8	.118				.236		.059			▲/▲		
								P		●		
								M		●		
								K		●		
								S		●		
								N		●		
								H				

- ▲ on stock Δ 4 weeks
- main recommendation
- alternative recommendation
- uncoated grades
- coated grades
- brazed/Cermet

Dimensions in inch
 State R or L version

Carbide grades

INSERT Type

105

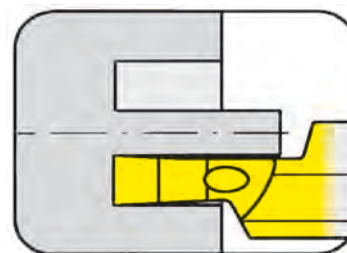

from outer groove \varnothing .315"
 Depth of groove up to .236"
 Width of groove up to .118"

for use with Toolholder

- Type BU105
 B105
 B105C
 B105KM
 BKT
 H105
 HC105
 VDI

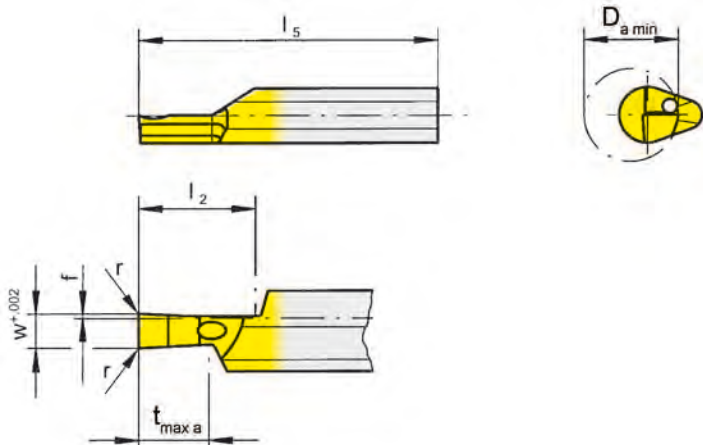

R = right hand version shown

L = left hand version

Part number	w	f	l ₂	l ₅	t _{max a}	D _{a min}	r	Carbide grades					
								MG12	TN35	TI25	TF45	TH35	
R/L105.0810.1.9	.039				.079					▲▲			
R/L105.0815.1.9	.059				.118					▲▲			
R/L105.0820.1.9	.079	.016	.394	.984	.157	.315	.006			▲▲			
R/L105.0825.1.9	.098				.197					▲▲			
R/L105.0830.1.9	.118				.236					▲▲			
								P		●			
								M		●			
								K		●			
								S		●			
								N		●			
								H					

- ▲ on stock Δ 4 weeks
- main recommendation
- alternative recommendation
- uncoated grades
- coated grades
- brazed/Cermet

Dimensions in inch

State R or L version

Carbide grades

INSERT Type

105

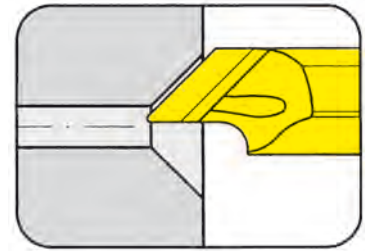

Angle of chamfer 45° / 60°
Width of chamfer up to .157"

for use with Toolholder

- Type BU105
B105
B105C
B105KM
BKT
H105
HC105
VDI

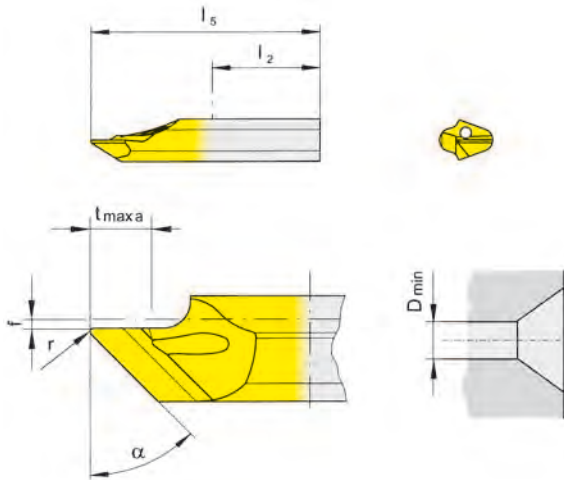

R = right hand version shown

L = left hand version

Part number	α	f	l ₂	l ₅	t _{max a}	D _{min}	r	Carbide grades				
								MG12	TN35	TI25	TF45	TH35
R/L105.0045.0.1	45°	.020	.472	.787	.138	.039	.008		▲/▲		/▲	
R/L105.0045.1.1									▲/▲		▲/▲	
R/L105.0060.0.1	60°	.020	.472	.787	.157	.039	.008				/▲	
R/L105.0060.1.1											▲/▲	
								P	•	•	•	•
								M	•	•	•	•
								K	•	•	•	•
								S	•	•	•	•
								N	•	•	•	•
								H				

- ▲ on stock Δ 4 weeks
- main recommendation
- o alternative recommendation
- uncoated grades
- coated grades
- brazed/Cermet

Dimensions in inch

State R or L version

Carbide grades

TOOLHOLDER Type

BU105

with through coolant supply

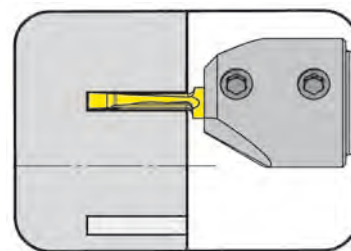

from outer groove Ø	.394"
Depth of groove up to	.591"
Width of groove up to	.118"

Clamping length 22 mm

for use with Insert

Type A105

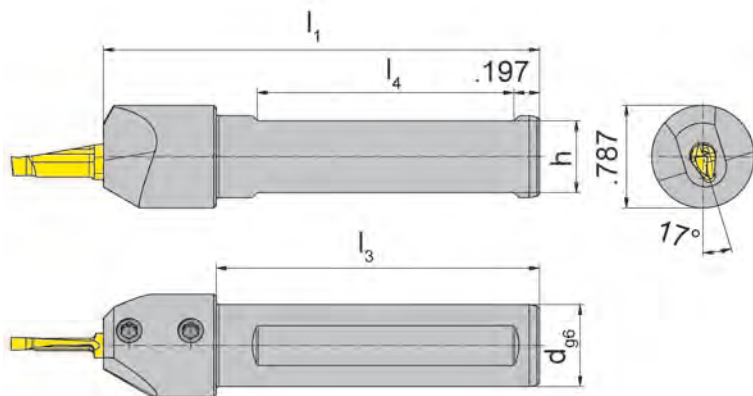

L = left hand version shown

R = right hand version

only usable for inserts with extended clamping length

Part number	d	l ₁	h	l ₃	l ₄
R/LBU105.0625.12.2	.625	3.347	.546	2.480	1.969
R/LBU105.0750.12.2	.750	3.937	.671	-	2.165
R/LBU105.1000.12.2	1.000		.921		

State R or L version

Dimensions in inch

Further sizes upon request

Spare parts

Toolholder	Screw	TORX PLUS® Wrench
R/LBU105....	6.075T15P	T15PQ

A112

TOOLHOLDER Type

B105

with through coolant supply

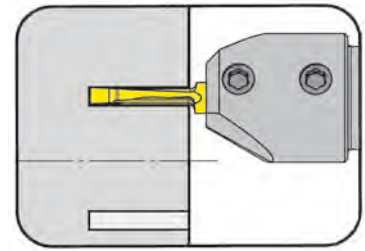

from outer groove \varnothing .394" (10.0 mm)
 Depth of groove up to .591" (15.0 mm)
 Width of groove up to .118" (3.0 mm)

Clamping length 22 mm

for use with Insert

Type A105

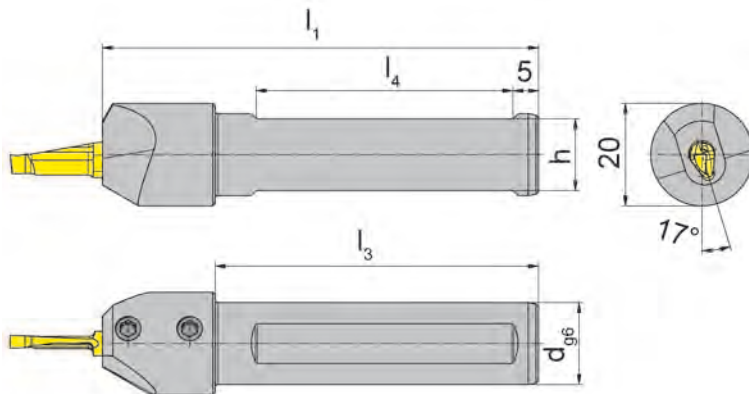

L = left hand version shown

R = right hand version

only usable for inserts with extended clamping length

Part number	d	l ₁	h	l ₃	l ₄
R/LB105.0016.12.2	16	85	14	63	50
R/LB105.0020.12.2	20	100	18	-	55

State R or L version

Dimensions in mm

Further sizes upon request

Spare parts

Toolholder	Screw	TORX PLUS® Wrench
R/LB105.00...	6.075T15P	T15PQ

INSERT Type

A105

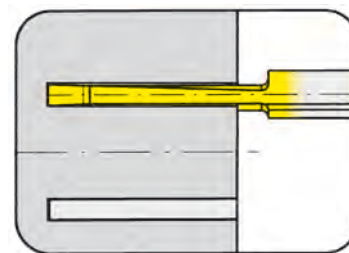

from outer groove Ø	.394"
Depth of groove up to	.591"
Width of groove up to	.118"

for use with Toolholder

Type BU105...12.2
B105...12.2

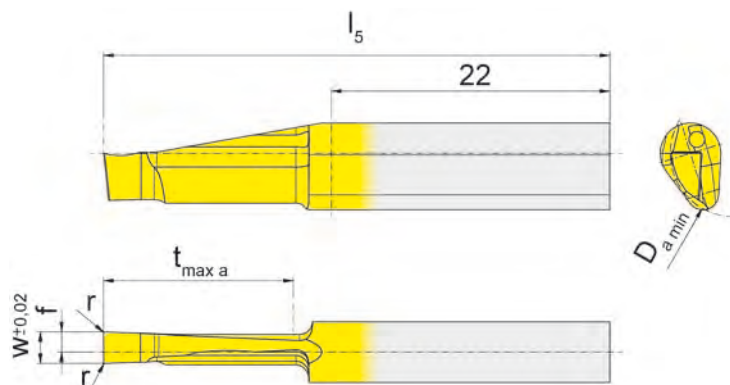

L = left hand version shown

R = right hand version

Part number	w	f	l ₅	t _{max a}	D _{a min}	r	Carbide grades				
							MG12	TN35	TI25	TF45	TH35
R/LA105.1020.2.2	.079	.055							▲▲		
R/LA105.1025.2.2	.098	.063	1.575	.591	.394	.004			▲▲		
R/LA105.1030.2.2	.118	.075							▲/▲		
							P		●		
							M		●		
							K		●		
							S		●		
							N		●		
							H				

- ▲ on stock Δ 4 weeks
- main recommendation
- alternative recommendation
- uncoated grades
- coated grades
- brazed/Cermet

Dimensions in inch

Carbide grades

State R or L version

Note:

Use insert RA105 in toolholder RB105
Use insert LA105 in toolholder LB105

Face grooving with full width of the full depth only possible between D_{amin} .394" - 1.575"!

Groove milling with System 275
from Cutting edge \emptyset

\emptyset 1.221" (31.0 mm)

Example:

Milling cutter M275.0078.A32.14

Cutting edge \emptyset 3.071" (78.0 mm)

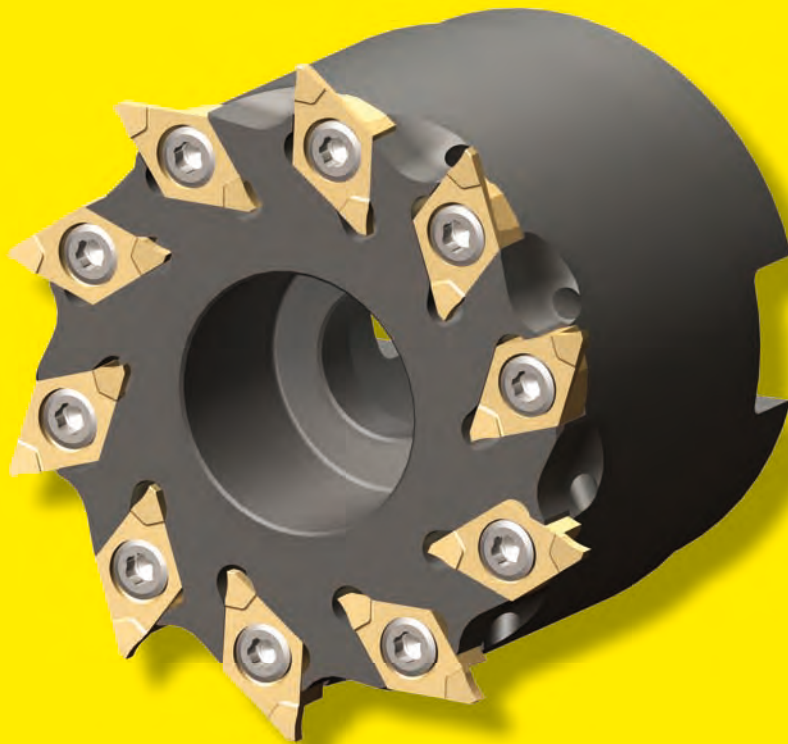

For further information, please see HORN catalog "CARBIDE MILLING TOOLS".

TOOLHOLDER Type

BU105...02

with through coolant supply

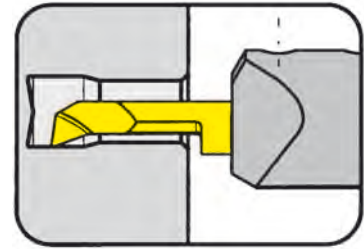

Bore Ø from .197"

for use with Insert

Type 105...2

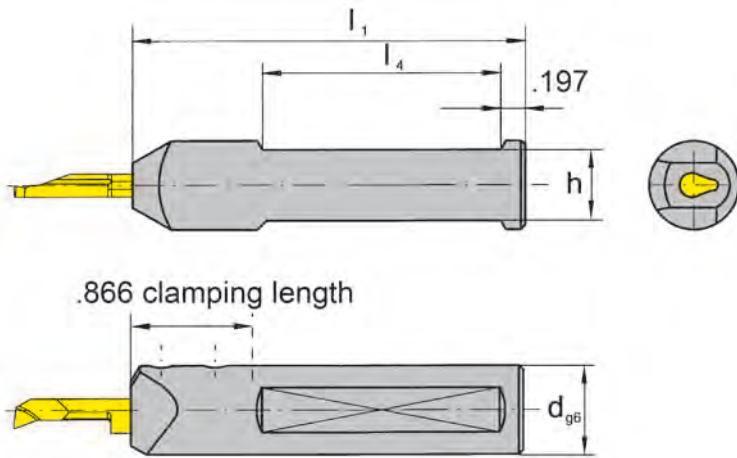

Picture = right hand cutting version shown

only usable for inserts with extended clamping length

Part number	d	l ₁	h	l ₄
BU105.0500.02	.500	3.346	.433	1.969
BU105.0625.02	.625	3.346	.551	1.969
BU105.0750.02	.750	3.937	.709	2.165

Further sizes upon request

Dimensions in inch

Spare parts

Toolholder	Screw	TORX PLUS® Wrench
BU105.0...	6.075T15P	T15PQ

TOOLHOLDER Type

B105...02

with through coolant supply

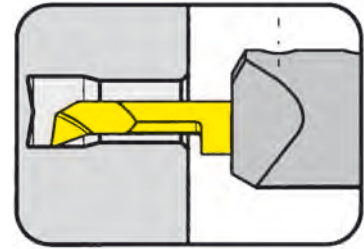

Bore Ø from .472" (12.0 mm)

for use with Insert

Type 105...2

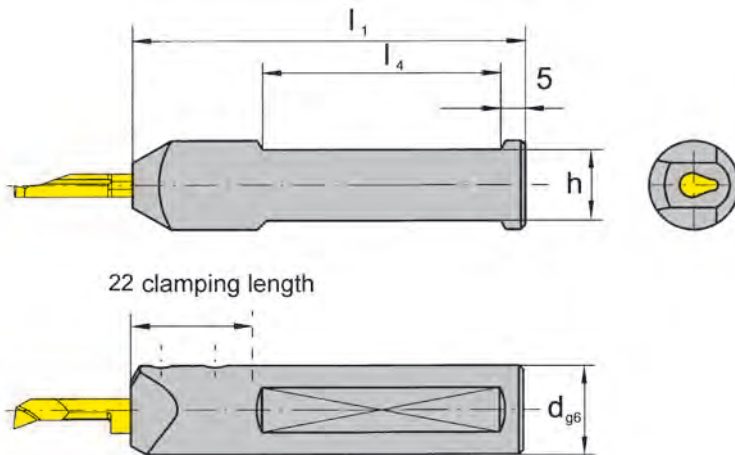

Picture = right hand cutting version shown

only usable for inserts with extended clamping length

Part number	d	l ₁	h	l ₄
B105.0012.02	12	85	11	50
B105.0016.02	16	85	14	50
B105.0020.02	20	100	18	55
B105.0022.02	22	100	20	55

Further sizes upon request

Dimensions in mm

Ordering note:

Toolholders can be used with right and left hand inserts.

Spare parts

Toolholder	Screw	TORX PLUS® Wrench
B105.00...	6.075T15P	T15PQ

TOOLHOLDER Type

B105C

with through coolant supply

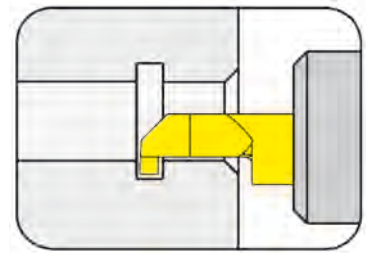

Adapter for inserts type 105 HORN-Capto

Clamping length 22 mm

for use with Insert

Type 105...2

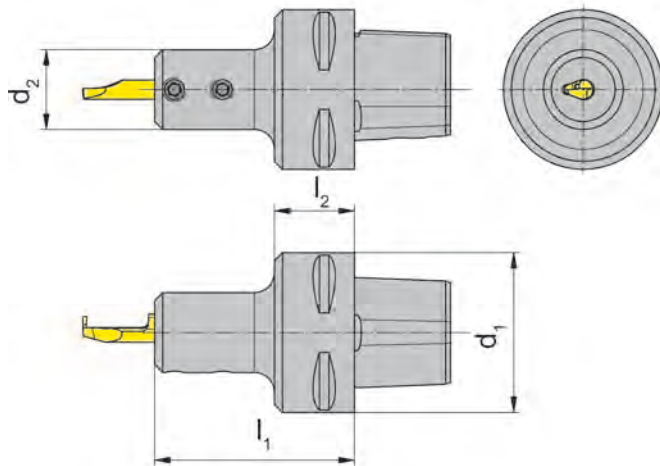

L = left hand version shown

R = right hand version

only usable for inserts with extended clamping length

Part number	l_1	l_2	d_2	d_1	Remark
R/LB105.00C4.20.1.02	50	20	20	40	C4
R/LB105.00C6.20.1.02	52	22	20	63	C6

State R or L version

Dimensions in mm

Further sizes upon request

Spare parts

Toolholder	Screw	TORX PLUS® Wrench
R/LB105.00C...	6.075T15P	T15PQ

A118

INSERT Type

105

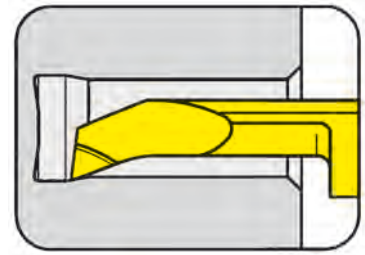

Bore Ø from .197"

Clamping length 22 mm

for use with Toolholder

Type BU105...02
B105...02
B105C...02

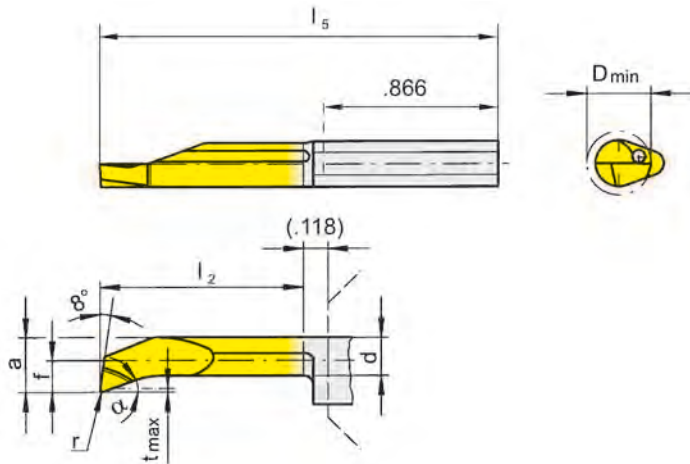

R = right hand version shown

L = left hand version

with extended clamping length

Part number	f	a	d	l_2	l_5	t_{max}	D_{min}	r	α	Carbide grades					
										MG12	TN35	TI25	TF45	TH35	
R/L105.1823.4.5.2	.091	.185	.165	.984	1.969	.012	.197	.004	20°			▲▲		▲▲	
R/L105.1823.5.5.2				1.181	2.165					▲▲		▲▲			
R/L105.1833.4.6.2	.130	.224	.193	.984	1.969	.012	.236	.004	20°			▲/▲		▲/▲	
R/L105.1833.5.6.2				1.181	2.165					▲▲		▲▲			
R/L105.1840.4.7.2	.157	.252	.213	.984	1.969	.012	.268	.004	20°			▲/▲		▲/▲	
R/L105.1840.5.7.2				1.181	2.165					▲/▲		▲/▲			
R/L105.1840.7.7.2				1.575	2.559					▲/					
R/L105.4733.5.6.2	.130	.224	.146	1.181	2.165	.071	.236	.004	47°			▲▲		▲▲	
											P		•		•
											M		•		•
											K		•		•
											S		•		•
											N		•		•
											H				

- ▲ on stock Δ 4 weeks
- main recommendation
- o alternative recommendation
- uncoated grades
- coated grades
- brazed/Cermet

Dimensions in inch

State R or L version

Carbide grades

HCG - HORN Catalog Guide

Bore Ø	Product line								
	105	110	108	10P	111	11P	114	116	18P
≥ .008" (0.2 mm)	•								
≥ .236" (6.0 mm)	•	•							
≥ .268" (6.8 mm)	•	•							
≥ .307" (7.8 mm)		•	•						
≥ .315" (8.0 mm)		•	•						
≥ .346" (8.8 mm)				•					
≥ .354" (9.0 mm)		•	•	•					
≥ .386" (9.8 mm)					•	•			
≥ .394" (10.0 mm)		•		•	•				
≥ .419" (10.5 mm)						•			
≥ .433" (11.0 mm)					•	•			
≥ .492" (12.5 mm)							•		
≥ .551" (14.0 mm)							•	•	
≥ .630" (16.0 mm)								•	
≥ .650" (16.5 mm)							•		
≥ .689" (17.5 mm)									•

Groove depth ≤ (inch)	.098"	.157"	.039"	.118"	.091"	.138"	.256"	.169"	.315"
Groove depth ≤ (mm)	2.5	4.0	1.0	3.0	2.3	3.5	6.5	4.3	8.0
Width of groove inch	.020"-.079"	.039"-.250"	.029"-.079"	.039"-.118"	.029"-.125"	.039"-.118"	.029"-.125"	.029"-.157"	.071"-.118"
Width of groove mm	0.5 - 2.0	1.0 - 6.35	0.74 - 2.0	1.0 - 3.0	0.74 - 3.18	1.0 - 3.0	0.74 - 3.18	0.74 - 4.0	1.8 - 3.0

Application	Product line								
	105	110	108	10P	111	11P	114	116	18P
Grooving	•	•	•	•	•	•	•	•	•
Boring	•	•	•	•	•	•	•	•	•
Threading	•		•		•		•	•	
Chamfering	•		•		•		•	•	
Face Grooving	•	•					•		
Hard turning	•		•		•		•	•	

Chapter	A	B	C	D	E	F	G	H	J
---------	----------	----------	----------	----------	----------	----------	----------	----------	----------

Special tools upon request

Supermini® CARBIDE GROOVING TOOLS

BU/B110, VDI...110
N79IK
 Toolholder



Page B2-B4



Page B5-B6



Page B7



Page B8



Page B9

U110 / 110
 $\geq \text{Ø } .236'' (6.0 \text{ mm})$
 Inserts

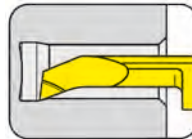

Page B10

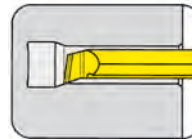

Page B11

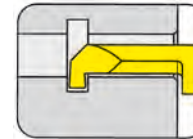

Page B12-B18

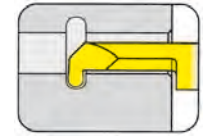

Page B20-B21

BU110 / B110
 Face Grooving
 Toolholder



Page B22-B23

A110
 Face Grooving
 Inserts

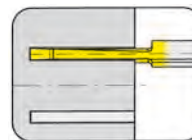

Page B24

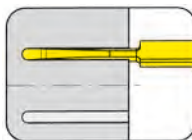

Page B25

B

TOOLHOLDER Type

BU110

with through coolant supply

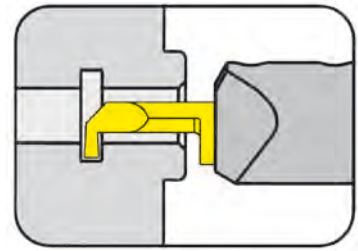

Bore Ø from	.236"
Depth of groove up to	.157"
Width of groove up to	.250"

for use with Insert

Type 110
U110

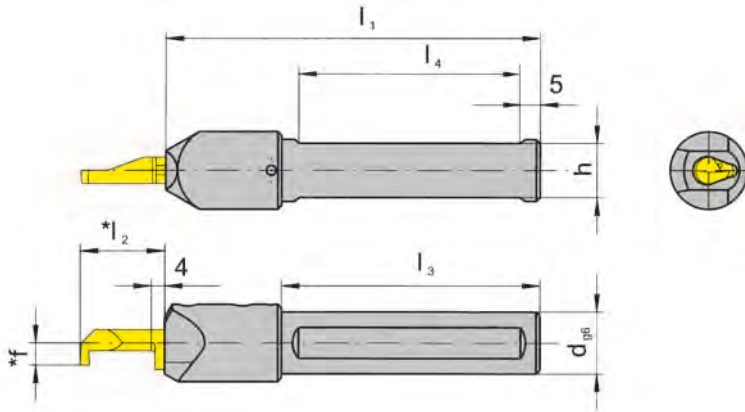

Picture = right hand cutting version shown

Part number	d	l ₁	h	l ₃	l ₄
BU110.0625.02	.625	3.937	.551	2.756	2.165
BU110.0750.02	.750	3.937	.709	-	2.165

Further sizes upon request

f, l₂ see inserts type 110

Dimensions in inch

Ordering note:

Toolholders can be used with right and left hand inserts.

Spare parts

Toolholder	Screw	TORX PLUS® Wrench
BU110.0...	6.075T15P	T15PQ

B2

TOOLHOLDER Type

B110

with through coolant supply

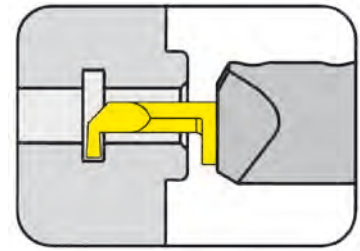

Bore Ø from	.236" (6.0 mm)
Depth of groove up to	.157" (4.0 mm)
Width of groove up to	.250" (6.35 mm)

Extended depth of insert seat

for use with Insert

Type 110
U110

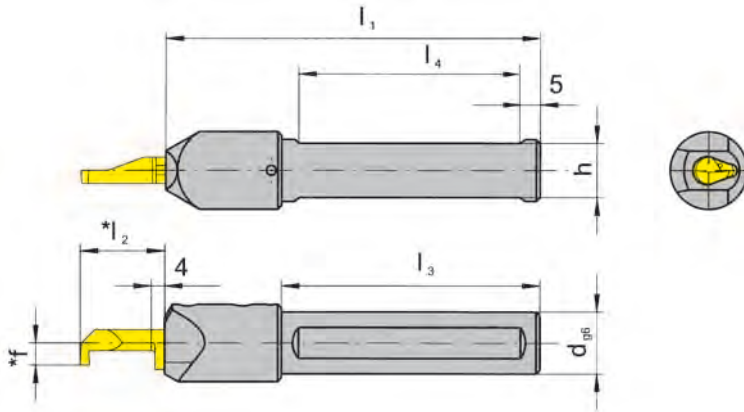

Picture = right hand cutting version shown

Part number	d	l ₁	h	l ₃	l ₄
B110.0016.02	16	100	14	70	55
B110.0020.02	20	100	18	-	55
B110.0022.02	22	100	20	-	55
B110.0025.02	25	100	23	-	55

Further sizes upon request

f, l₂ see inserts type 110

Dimensions in mm

Ordering note:

Toolholders can be used with right and left hand inserts.

Spare parts

Toolholder	Screw	TORX PLUS® Wrench
B110.00...	6.075T15P	T15PQ

B

TOOLHOLDER Type

B110

with through coolant supply

Bore Ø from	.236" (6.0 mm)
Depth of groove up to	.157" (4.0 mm)
Width of groove up to	.250" (6.35 mm)

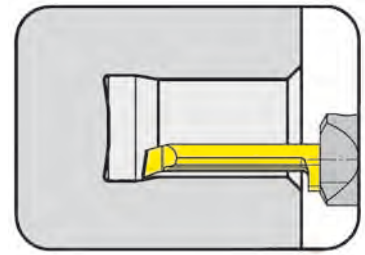

for use with Insert

Type 110
U110

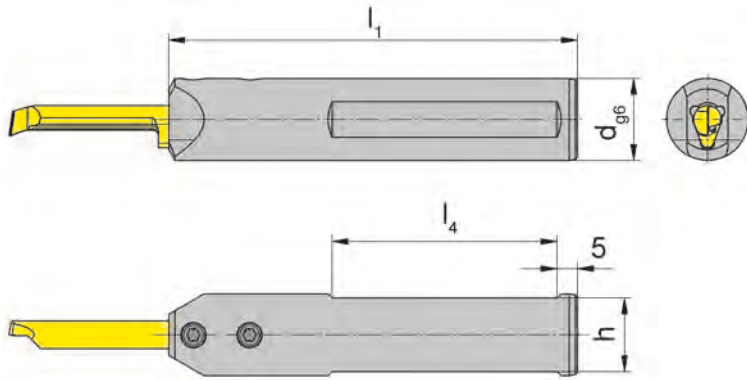

Picture = right hand cutting version shown

with additional through coolant bores

Part number	d	l ₁	h	l ₄
B110.0020.K.02	20	100	18	55

Further sizes upon request

f, L see inserts type 110

Dimensions in mm

Ordering note:

Toolholders can be used with right and left hand inserts.

Spare parts

Toolholder	Screw	TORX PLUS® Wrench
B110.0020.K.02	6.075T15P	T15PQ

B4

TOOLHOLDER Type

B110C

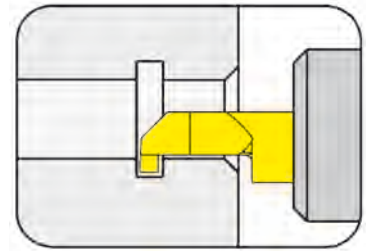

Adapter for inserts type 110 HORN-Capto

for use with Insert

Type 110
U110

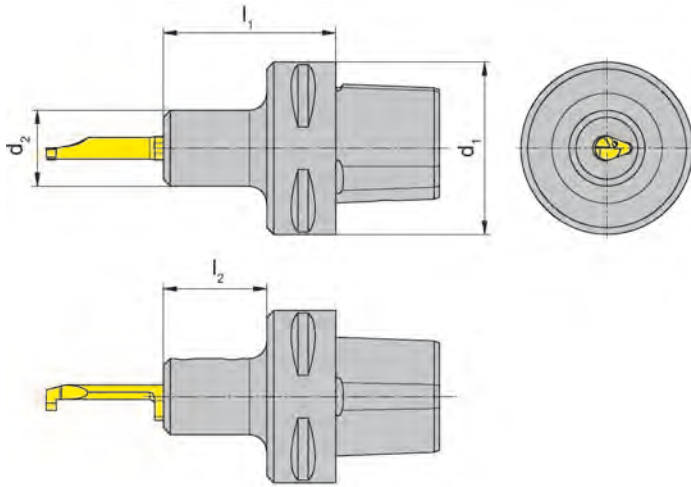

R = right hand version shown

L = left hand version

Licence Sandvik

Part number	l_1	l_2	d_2	d_1	Remark
R/LB110.00C5.22.1.02	50	30	22	50	C5

Further sizes upon request

Dimensions in mm

Spare parts

Toolholder	Screw	TORX PLUS® Wrench
R/LB110.00C5.22.1.02	6.075T15P	T15PQ

TOOLHOLDER Type

B110C

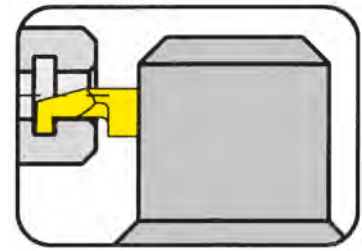

Adapter for inserts type 110 HORN-Capto

for INDEX Multi spindle machines

for use with Insert

Type 110
U110

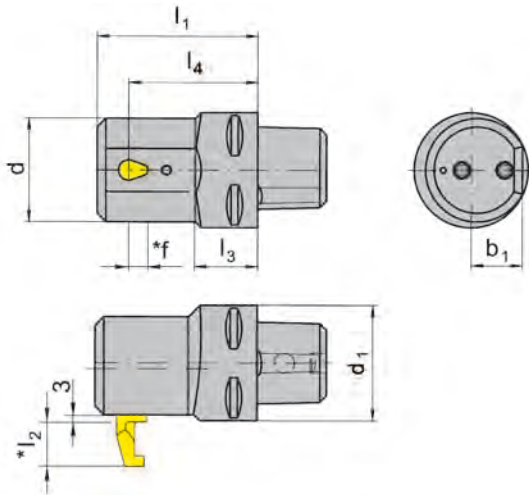

Picture = right hand cutting version shown

Licence Sandvik

Part number	d	l ₁	l ₃	b ₁	l ₄	d ₁	Remark	Type of machine
RB110.00C3.2.2.02	36	56	15	18	45	32	C3	MS32
RB110.00C4.2.2.02	36	56	22	18	45	40	C4	MS52

Further sizes upon request

f, l₂ see inserts type 110

Dimensions in mm

Spare parts

Toolholder	Screw	TORX PLUS® Wrench
RB110.00C...	6.075T15P	T15PQ

TOOLHOLDER Type

B110KM

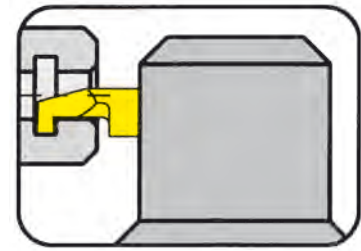

Adapter for inserts type 110 HORN-KM

for INDEX Multi spindle machines

for use with Insert

Type 110
U110

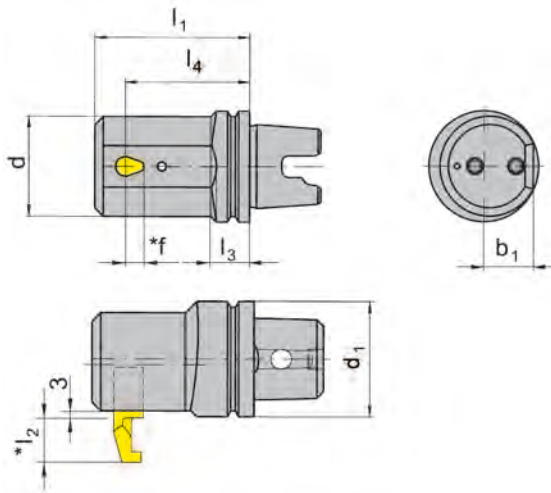

Picture = right hand cutting version shown

Licence Kennametal

Part number	d	l ₁	l ₃	b ₁	l ₄	d ₁	Type of machine
RB110.KM40.2.2.02	36	56	14	18	45	40	MS32
RB110.KM50.2.2.02	36	56	22	18	45	50	MS52

Further sizes upon request

f, l₂ see inserts type 110

Dimensions in mm

Spare parts

Toolholder	Screw	TORX PLUS® Wrench
RB110.KM...	6.075T15P	T15PQ

B

TOOLHOLDER Type

VDI

with through coolant supply

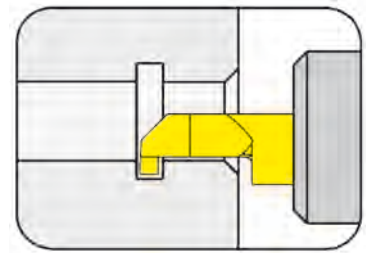

Bore Ø from .236" (6.0 mm)

for use with Insert

Type 110
U110

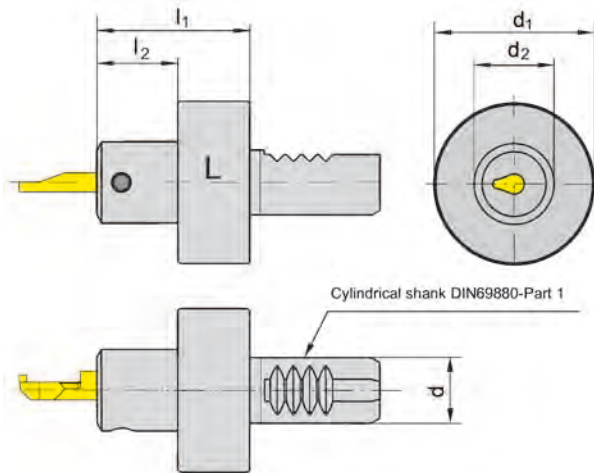

L = left hand version shown

R = right hand version

Part number	d	l ₁	l ₂	d ₂	d ₁
VDI16.R/L110.30.02	16	48	30	22	40
VDI20.R/L110.30.02	20	48	30	22	50
VDI25.R/L110.30.02	25	48	30	22	58
VDI30.R/L110.30.02	30	48	30	22	68

State R or L version

Dimensions in mm

Further sizes upon request

Spare parts

Toolholder	Screw	TORX PLUS® Wrench
VDI...	6.075T15P	T15PQ

ADJUSTABLE HOLDER Type

N



B

Bore Ø from	.236" (6.0 mm)
Depth of groove up to	.157" (4.0 mm)
Width of groove up to	.250" (6.35 mm)

with through coolant supply

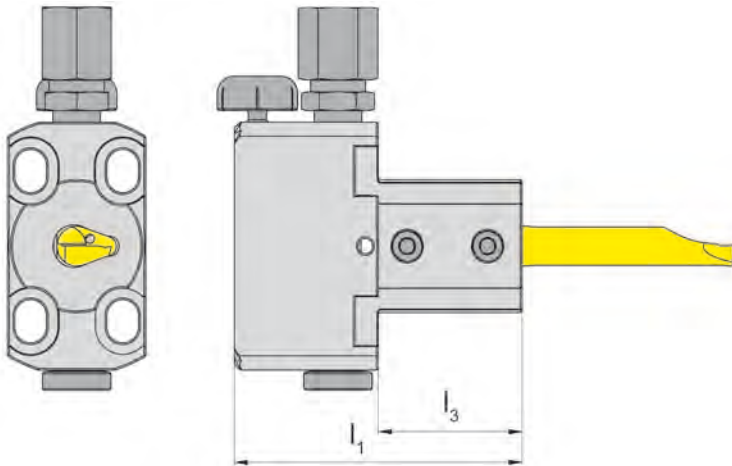

for use with Insert

Type 110
U110



Picture = right hand cutting version shown

Part number	l_1	l_3
N791K	50	25

Further sizes upon request

Dimensions in mm

Spare parts

Adjustable holder	Screw	Height adjustment screw	Coolant supply
N791K	6.075T15P	002.00.69	004.00.19

INSERT Type

110

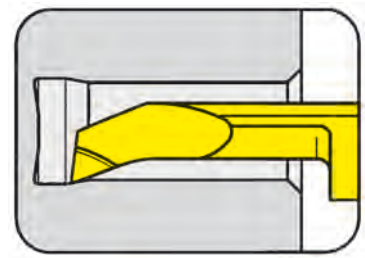

Bore Ø from .236''

for use with Toolholder

Type BU110
B110
B110C
VDI

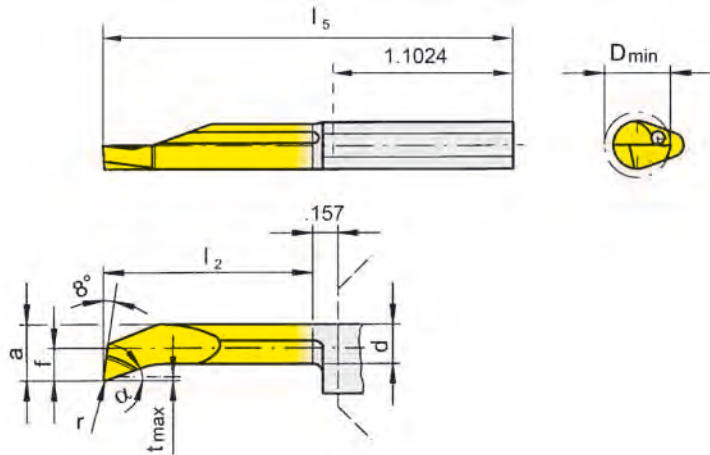

R = right hand version shown

L = left hand version

Part number	f	a	d	l ₂	l ₅	t _{max}	D _{min}	r	Carbide grades				
									MG12	TN35	TI25	TF45	TH35
R/L110.1829.7.6	.114	.224	.189	1.575	2.756	.020	.236	.008			▲▲		▲▲
R/L110.1829.9.6											▲▲		▲▲
R/L110.1829.9.8	.157	.291	.236	1.969	3.150	.020	.315	.008			▲/▲		▲/▲
▲ on stock Δ 4 weeks ● main recommendation ○ alternative recommendation □ uncoated grades ■ coated grades ■ brazed/Cermet									P		●		●
									M		●		●
									K		●		●
									S		●		●
									N		●		●
									H				

Dimensions in inch

State R or L version

INSERT Type

110

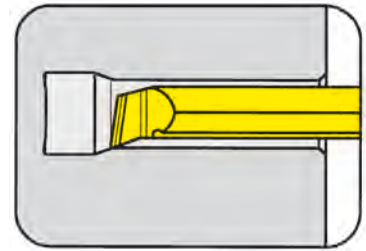

Bore Ø from .236''

for use with Toolholder

Type BU110
B110
B110C
VDI

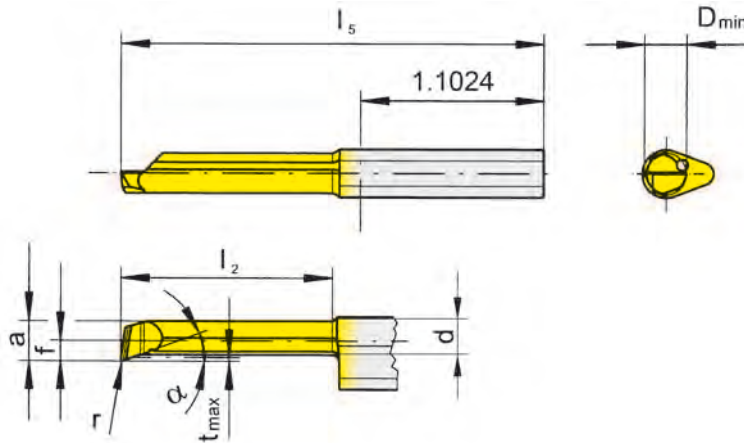

R = right hand version shown

with chip breaker
(geometry H)

Part number	f	a	d	l ₂	l ₅	t _{max}	D _{min}	r	Carbide grades				
									MG12	TN35	TI25	TF45	TH35
R110.1829.9.H6	.114	.224	.189	1.969	3.150	.020	.236	.008			Δ		
R110.1829.9.H8	.157	.291	.236	1.969	3.150	.020	.315	.008			Δ		
									P		•		
									M		•		
									K		•		
									S		•		
									N		•		
									H				

- ▲ on stock Δ 4 weeks
- main recommendation
- o alternative recommendation
- uncoated grades
- coated grades
- brazed/Cermet

Dimensions in inch

Carbide grades

GROOVING (internal) $\geq \text{Ø} .315''$



B

INSERT Type

110

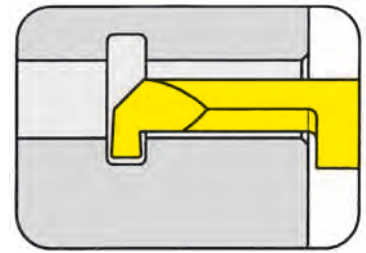

Bore Ø from .315''
 Depth of groove up to .110''

for use with Toolholder

Type BU110
 B110
 B110C
 VDI

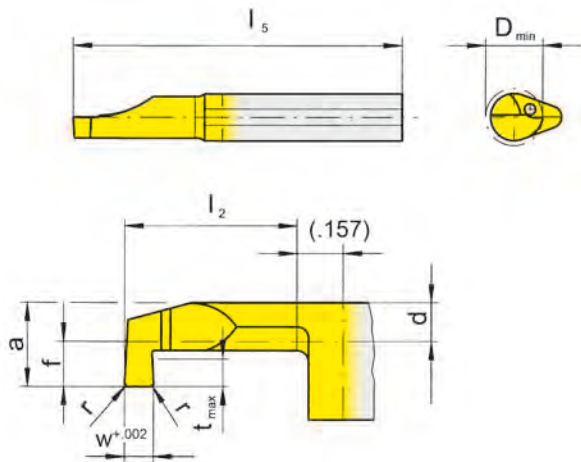

R = right hand version shown

with corner radius

Part number	w	f	a	d	l ₂	l ₅	t _{max}	D _{min}	r	Carbide grades					
										MG12	TN35	TI25	TF45	TH35	
R110.0200.02.3.8	.079	.157	.291	.165	.787	1.969	.110	.315	.008		▲				
▲ on stock Δ 4 weeks ● main recommendation ○ alternative recommendation □ uncoated grades ■ coated grades ■ brazed/Cermet											P	●			
											M	●			
											K	●			
											S	●			
											N	●			
											H				

Dimensions in inch

GROOVING (internal) $\geq \text{Ø} .315''$



B

INSERT Type

110

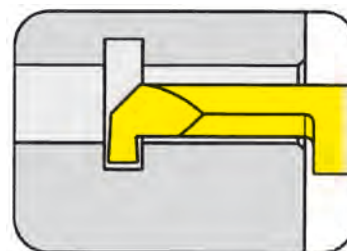

Bore Ø from $.315''$
Depth of groove up to $.157''$

for use with Toolholder

Type BU110
B110
B110C
VDI

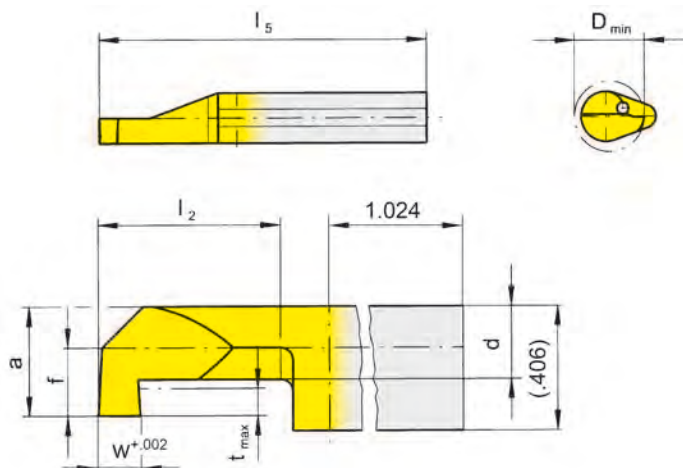

R = right hand version shown

L = left hand version

Part number	w	f	a	d	l ₂	l ₅	t _{max}	D _{min}	Carbide grades					
									MG12	TN35	TI25	TF45	TH35	
R/L110.0100.5.8	.039									▲/▲				
R/L110.0200.5.8	.079	.157	.291	.165	1.181	2.362	.110	.315		▲/▲				
R/L110.0250.5.8	.098									▲/▲				
R/L110.0100.7.8	.039									▲/Δ				
R/L110.0200.7.8	.079	.157	.291	.165	1.575	2.756	.110	.315		▲/▲				
R/L110.0250.7.8	.098									▲/Δ				
R/L110.0100.5.0	.039									▲/Δ				
R/L110.0200.5.0	.079	.236	.370	.197	1.181	2.362	.157	.394		▲/▲				
R/L110.0300.5.0	.118									▲/▲				
R/L110.0100.9.0	.039									▲/▲				
R/L110.0200.9.0	.079	.236	.370	.197	1.969	3.150	.157	.394		▲/▲				
R/L110.0300.9.0	.118									▲/Δ				
										P	•			
										M	•			
										K	•			
										S	•			
										N	•			
										H				

- ▲ on stock Δ 4 weeks
- main recommendation
- o alternative recommendation
- uncoated grades
- coated grades
- brazed/Cermet

Dimensions in inch

State R or L version

Carbide grades

GROOVING (internal) $\geq \text{Ø} .315''$



B

INSERT Type

U110

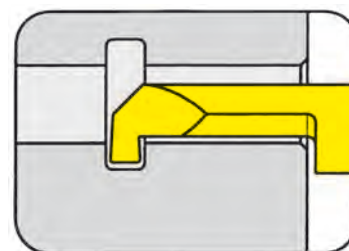

Bore Ø from $.315''$
 Depth of groove up to $.110''$

for use with Toolholder

Type BU110
 B110
 B110C
 VDI

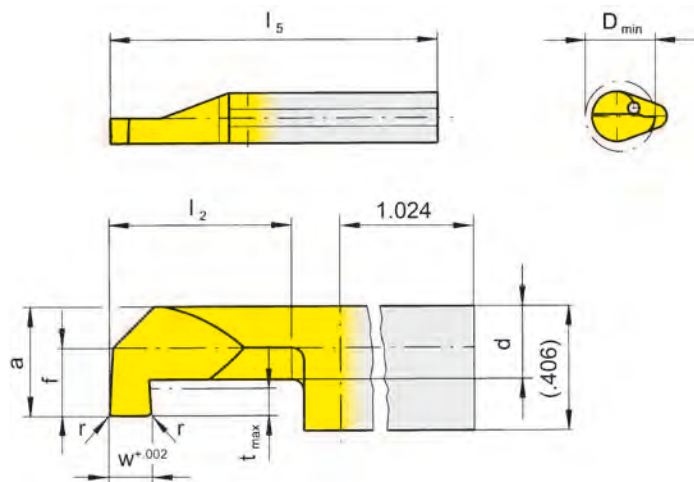

R = right hand version shown

L = left hand version

with corner radius

Part number	w	f	a	d	l ₂	l ₅	t _{max}	D _{min}	r	Carbide grades				
										MG12	TN35	TI25	TF45	TH35
R/LU110.4608.3.8	.046											▲/		
R/LU110.6208.3.8	.062											▲/		
R/LU110.7808.3.8	.078											▲/		
R/LU110.9408.3.8	.094	.157	.291	.165	.787	1.969	.110	.315	.008			▲/		
R/LU110.1208.3.8	.125											▲/Δ		
R/LU110.2508.3.8	.250											▲/		
R/LU110.4608.7.8	.046											▲/		
R/LU110.6208.7.8	.062											▲/Δ		
R/LU110.7808.7.8	.078											▲/		
R/LU110.9408.7.8	.094	.157	.291	.165	1.575	2.756	.110	.315	.008			▲/		
R/LU110.1208.7.8	.125											▲/		
R/LU110.2508.7.8	.250											▲/		
												P	•	
												M	•	
												K	•	
												S	•	
												N	•	
												H		

- ▲ on stock Δ 4 weeks
- main recommendation
- o alternative recommendation
- uncoated grades
- coated grades
- brazed/Cermet

Dimensions in inch
 State R or L version

Carbide grades

GROOVING (internal) $\geq \text{Ø} .315''$



B

INSERT Type

U110

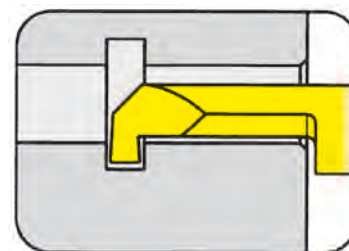

Bore Ø from .315''
 Depth of groove up to .110''

for use with Toolholder

Type BU110
 B110
 B110C
 VDI

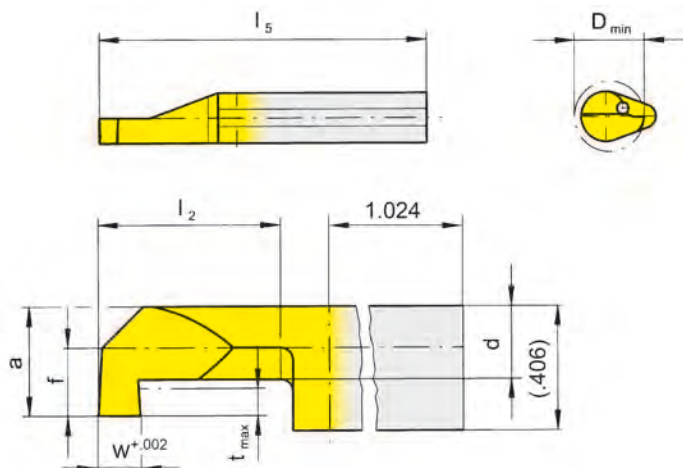

R = right hand version shown

L = left hand version

Part number	w	f	a	d	l ₂	l ₅	t _{max}	D _{min}	Carbide grades					
									MG12	TN35	TI25	TF45	TH35	
R/LU110.0046.3.8	.046										▲/			
R/LU110.0062.3.8	.062										▲/Δ			
R/LU110.0078.3.8	.078										▲/			
R/LU110.0094.3.8	.094	.157	.291	.165	.787	1.969	.110	.315			▲/▲			
R/LU110.0125.3.8	.125										▲/			
R/LU110.0250.3.8	.250										▲/			
R/LU110.0046.7.8	.046										▲/			
R/LU110.0062.7.8	.062										▲/			
R/LU110.0078.7.8	.078										▲/			
R/LU110.0094.7.8	.094	.157	.291	.165	1.575	2.756	.110	.315			▲/			
R/LU110.0125.7.8	.125										▲/			
R/LU110.0250.7.8	.250										▲/			
▲ on stock Δ 4 weeks ● main recommendation ○ alternative recommendation □ uncoated grades ■ coated grades ■ brazed/Cermet										P	●			
										M	●			
										K	●			
										S	●			
										N	●			
										H				

Dimensions in inch

Carbide grades

State R or L version

GROOVING (internal) $\geq \text{Ø} .394''$



B

INSERT Type

U110

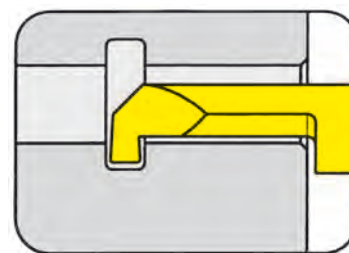

Bore Ø from $.394''$
 Depth of groove up to $.157''$

for use with Toolholder

Type BU110
 B110
 B110C
 VDI

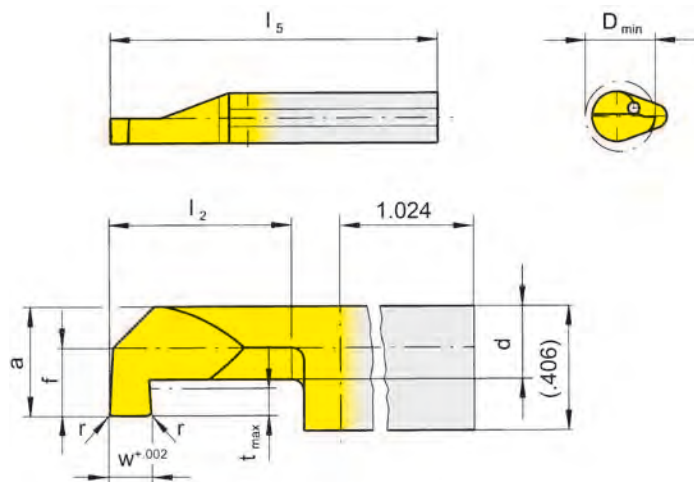

R = right hand version shown

L = left hand version

with corner radius

Part number	w	f	a	d	l ₂	l ₅	t _{max}	D _{min}	r	Carbide grades				
										MG12	TN35	TI25	TF45	TH35
R/LU110.4608.3.0	.046											▲/		
R/LU110.6208.3.0	.062											▲/▲		
R/LU110.7808.3.0	.078											▲/		
R/LU110.9408.3.0	.094	.236	.370	.197	.787	1.969	.157	.394	.008			▲/		
R/LU110.1208.3.0	.125											▲/Δ		
R/LU110.2508.3.0	.250											▲/▲		
R/LU110.4608.7.0	.046											▲/		
R/LU110.6208.7.0	.062											▲/		
R/LU110.7808.7.0	.078											▲/		
R/LU110.9408.7.0	.094	.236	.370	.197	1.575	2.756	.157	.394	.008			▲/		
R/LU110.1208.7.0	.125											▲/		
R/LU110.2508.7.0	.250											▲/		
												P	•	
												M	•	
												K	•	
												S	•	
												N	•	
												H		

- ▲ on stock Δ 4 weeks
- main recommendation
- o alternative recommendation
- uncoated grades
- coated grades
- brazed/Cermet

Dimensions in inch
 State R or L version

Carbide grades

B16

GROOVING (internal) $\geq \text{Ø} .394''$



B

INSERT Type

U110

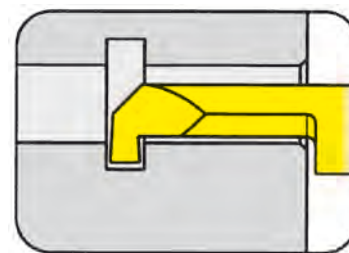

Bore Ø from .394''
 Depth of groove up to .157''

for use with Toolholder

Type BU110
 B110
 B110C
 VDI

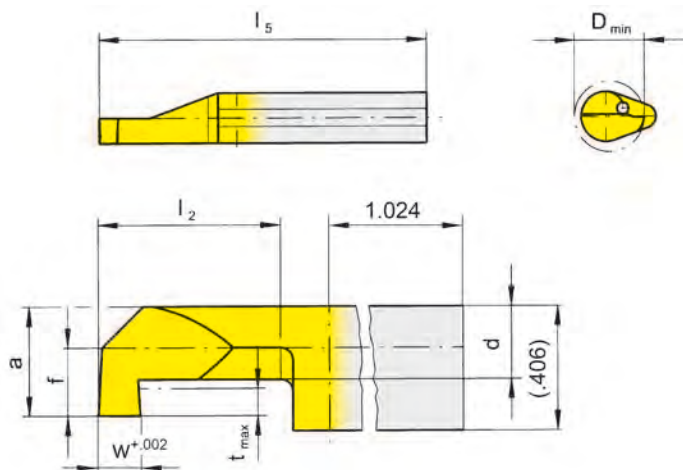

R = right hand version shown

L = left hand version

Part number	w	f	a	d	l ₂	l ₅	t _{max}	D _{min}	Carbide grades					
									MG12	TN35	TI25	TF45	TH35	
R/LU110.0046.1.0	.046										▲/			
R/LU110.0062.1.0	.062										▲/▲			
R/LU110.0078.1.0	.078	.236	.370	.197	.394	1.575	.157	.394			▲/Δ			
R/LU110.0094.1.0	.094										▲/			
R/LU110.0125.1.0	.125										▲/			
R/LU110.0046.3.0	.046										▲/			
R/LU110.0062.3.0	.062										▲/			
R/LU110.0078.3.0	.078										▲/			
R/LU110.0094.3.0	.094	.236	.370	.197	.787	1.969	.157	.394			▲/Δ			
R/LU110.0125.3.0	.125										▲/			
R/LU110.0250.3.0	.250										▲/			
▲ on stock Δ 4 weeks ● main recommendation ○ alternative recommendation □ uncoated grades ■ coated grades ■ brazed/Cermet										P		●		
										M		●		
										K		●		
										S		●		
										N		●		
										H				

Dimensions in inch

Carbide grades

State R or L version

GROOVING (internal) $\geq \text{Ø} .394''$



B

INSERT Type

U110

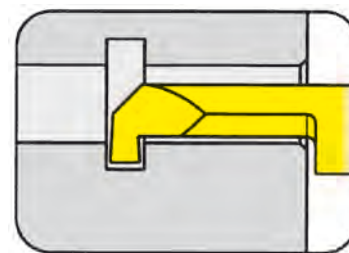

Bore Ø from .394''
 Depth of groove up to .157''

for use with Toolholder

Type BU110
 B110
 B110C
 VDI

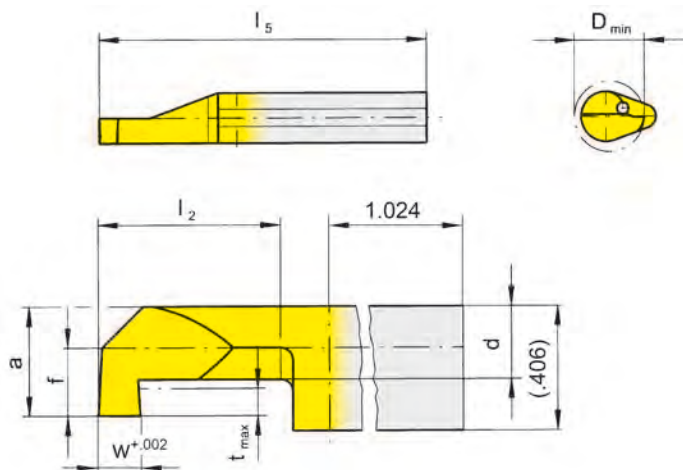

R = right hand version shown

L = left hand version

Part number	w	f	a	d	l ₂	l ₅	t _{max}	D _{min}	Carbide grades					
									MG12	TN35	TI25	TF45	TH35	
R/LU110.0046.5.0	.046										▲/			
R/LU110.0062.5.0	.062										▲/			
R/LU110.0078.5.0	.078										▲/			
R/LU110.0094.5.0	.094	.236	.370	.197	1.181	2.362	.157	.394			▲/Δ			
R/LU110.0125.5.0	.125										▲/			
R/LU110.0250.5.0	.250										▲/			
R/LU110.0046.7.0	.046										▲/			
R/LU110.0062.7.0	.062										▲/			
R/LU110.0078.7.0	.078										▲/			
R/LU110.0094.7.0	.094	.236	.370	.197	1.575	2.756	.157	.394			▲/			
R/LU110.0125.7.0	.125										▲/			
R/LU110.0250.7.0	.250										▲/			
▲ on stock Δ 4 weeks ● main recommendation ○ alternative recommendation □ uncoated grades ■ coated grades ■ brazed/Cermet										P		●		
										M		●		
										K		●		
										S		●		
										N		●		
										H				

Dimensions in inch

Carbide grades

State R or L version

B18

**High polish turning with
diamond tools type 105 and S117**



H10
technische Diamanten

For further information please see HORN catalog "CARBIDE GROOVING TOOLS".

GROOVING (internal) $\geq \text{Ø} .315''$



B

INSERT Type

U110

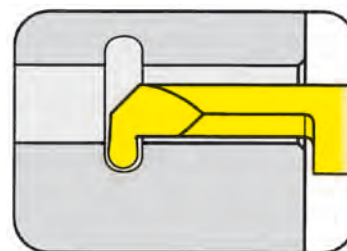

Bore Ø from $.315''$
Depth of groove up to $.110''$

for use with Toolholder

Type BU110
B110
B110C
VDI

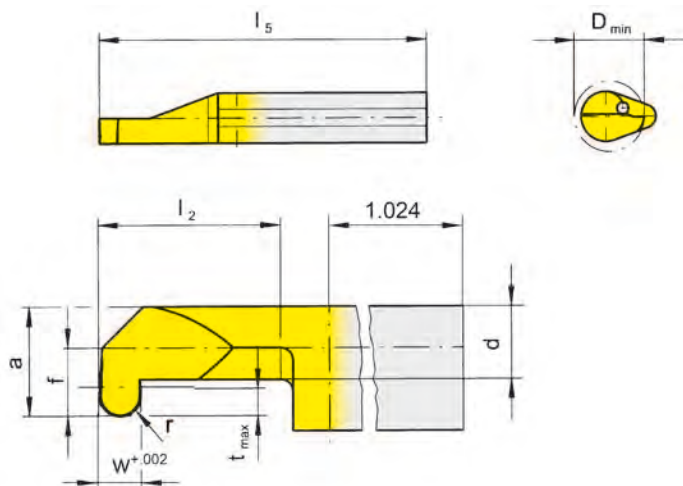

R = right hand version shown

L = left hand version

Full radius

Part number	w	f	a	d	l ₂	l ₅	t _{max}	D _{min}	r	Carbide grades				
										MG12	TN35	TI25	TF45	TH35
R/LU110.3162.1.8	.062								.031			▲▲		
R/LU110.4794.1.8	.094	.157	.291	.165	.394	1.575	.110	.315	.047			▲▲		
R/LU110.6212.1.8	.125								.062			▲▲		
R/LU110.3162.3.8	.062								.031			▲▲		
R/LU110.4794.3.8	.094	.157	.291	.165	.787	1.969	.110	.315	.047			▲/▲		
R/LU110.6212.3.8	.125								.062			▲/		
R/LU110.3162.5.8	.062								.031			▲/		
R/LU110.4794.5.8	.094	.157	.291	.165	1.181	2.362	.110	.315	.047			▲/		
R/LU110.6212.5.8	.125								.062			▲/		
R/LU110.3162.7.8	.062								.031			▲/		
R/LU110.4794.7.8	.094	.157	.291	.165	1.575	2.756	.110	.315	.047			▲/		
R/LU110.6212.7.8	.125								.062			▲/		
										P		•		
										M		•		
										K		•		
										S		•		
										N		•		
										H				

- ▲ on stock Δ 4 weeks
- main recommendation
- o alternative recommendation
- uncoated grades
- coated grades
- brazed/Cermet

Dimensions in inch
State R or L version

Carbide grades

B20

GROOVING (internal) $\geq \text{Ø} .394''$



INSERT Type

U110

B

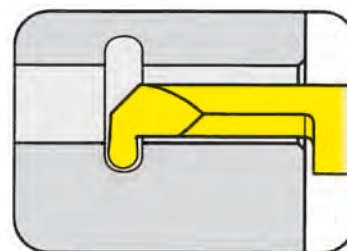

Bore Ø from $.394''$
Depth of groove up to $.157''$

for use with Toolholder

Type BU110
B110
B110C
VDI

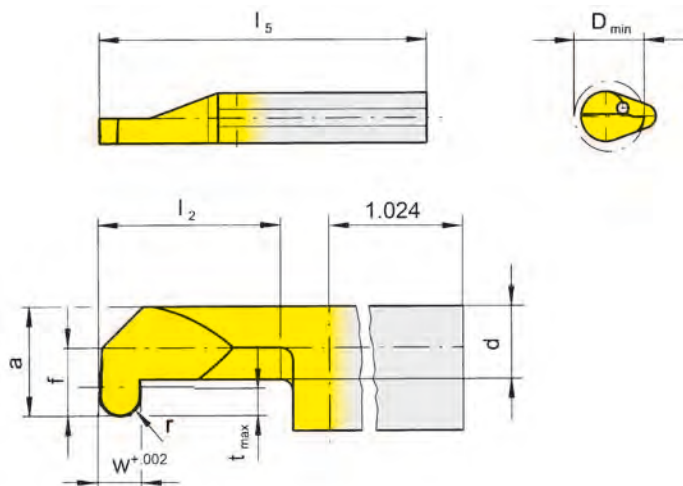

R = right hand version shown

L = left hand version

Full radius

Part number	w	f	a	d	l ₂	l ₅	t _{max}	D _{min}	r	Carbide grades				
										MG12	TN35	TI25	TF45	TH35
R/LU110.3162.1.0	.062								.031			▲/▲		
R/LU110.4794.1.0	.094	.236	.370	.197	.394	1.575	.157	.394	.047			▲/		
R/LU110.6212.1.0	.125								.062			▲/		
R/LU110.3162.3.0	.062								.031			▲/		
R/LU110.4794.3.0	.094	.236	.370	.197	.787	1.969	.157	.394	.047			▲/Δ		
R/LU110.6212.3.0	.125								.062			▲/		
R/LU110.3162.5.0	.062								.031			▲/▲		
R/LU110.4794.5.0	.094	.236	.370	.197	1.181	2.362	.157	.394	.047			▲/▲		
R/LU110.6212.5.0	.125								.062			▲/		
R/LU110.3162.7.0	.062								.031			▲/		
R/LU110.4794.7.0	.094	.236	.370	.197	1.575	2.756	.157	.394	.047			▲/▲		
R/LU110.6212.7.0	.125								.062			▲/		
										P		•		
										M		•		
										K		•		
										S		•		
										N		•		
										H				

- ▲ on stock Δ 4 weeks
- main recommendation
- o alternative recommendation
- uncoated grades
- coated grades
- brazed/Cermet

Dimensions in inch
State R or L version

Carbide grades

FACE GROOVING



B

TOOLHOLDER Type

BU110

with through coolant supply

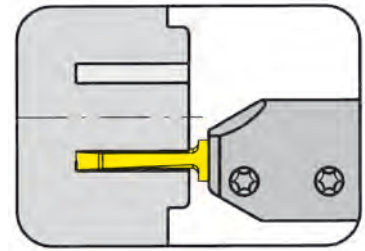

from outer groove Ø	.787"
Depth of groove up to	1.181"
Width of groove up to	.118"

for use with Insert

Type A110

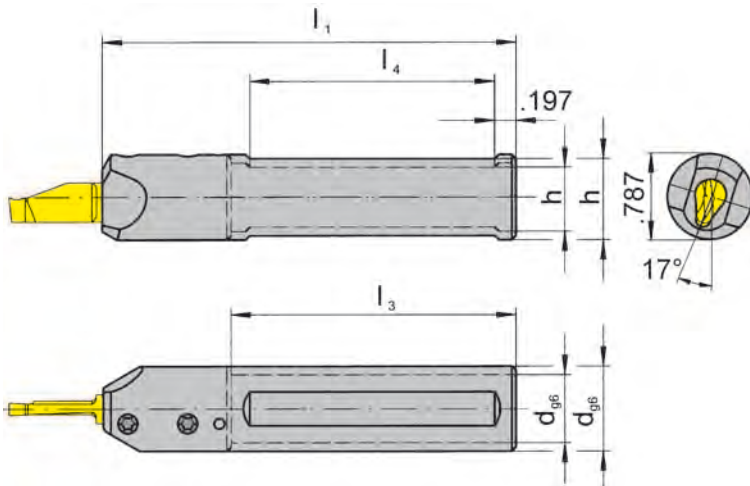

R = right hand version shown

L = left hand version

Part number	d	l ₁	h	l ₃	l ₄
R/LBU110.0625.16.2	.625	3.397	.551	2.756	2.165
R/LBU110.0750.16.2	.750	3.397	.709	-	2.165

State R or L version

Dimensions in inch

Further sizes upon request

Spare parts

Toolholder	Screw	TORX PLUS® Wrench
R/LBU110.0...	6.075T15P	T15PQ

B22

TOOLHOLDER Type

B110

with through coolant supply

from outer groove Ø	.787" (20.0 mm)
Depth of groove up to	1.181" (30.0 mm)
Width of groove up to	.118" (3.0 mm)

Extended depth of insert seat

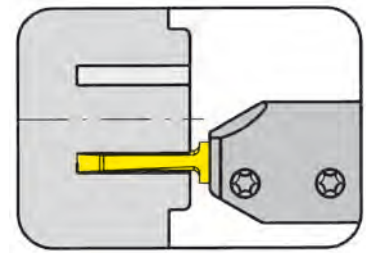

for use with Insert

Type A110

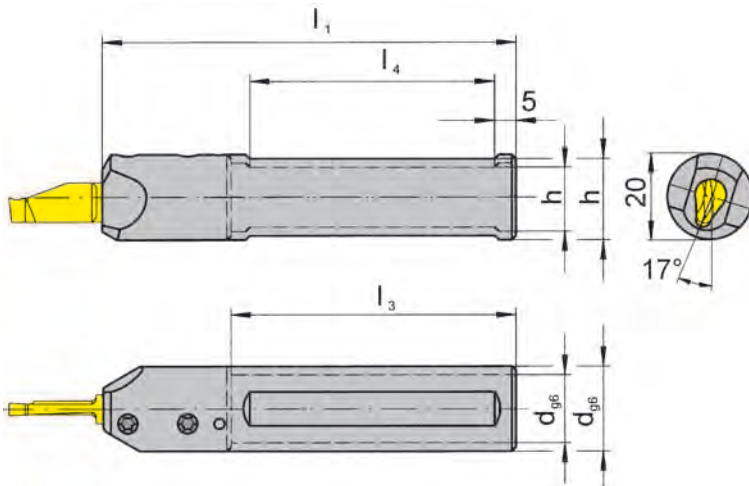

R = right hand version shown

L = left hand version

Part number	d	l ₁	h	l ₃	l ₄
R/LB110.0016.16.2	16	100	14	70	55
R/LB110.0020.16.2	20	100	18	-	55

State R or L version

Dimensions in mm

Further sizes upon request

Spare parts

Toolholder	Screw	TORX PLUS® Wrench
R/LB110.00...	6.075T15P	T15PQ

INSERT Type

A110

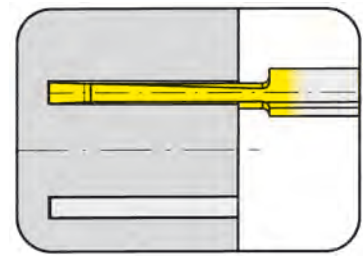

from outer groove \varnothing .787"
 Depth of groove up to 1.181"
 Width of groove up to .118"

for use with Toolholder

Type B110...16.2
 BU110...16.2

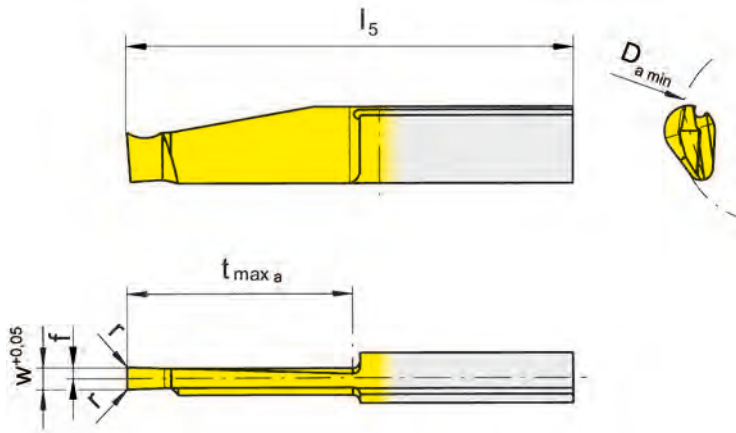

L = left hand version shown

R = right hand version

Part number	w	f	l ₅	t _{max a}	D _{a min}	r	Carbide grades				
							MG12	TN35	TI25	TF45	TH35
R/LA110.2030.3.0	.118	.059	1.969	.787	.787	.008		▲/▲	▲/▲		▲/▲
R/LA110.2030.5.0			2.362	1.181			▲/▲	▲/▲		▲/▲	
R/LA110.5030.3.0	.118	.059	1.969	.787	1.969	.008			▲/▲		
R/LA110.5030.5.0			2.362	1.181			▲/▲	▲/▲			
							P	•	•		•
							M	•	•		•
							K	•	•		•
							S	•	•		•
							N	•	•		•
							H				

- ▲ on stock Δ 4 weeks
- main recommendation
- o alternative recommendation
- uncoated grades
- coated grades
- brazed/Cermet

Dimensions in inch

State R or L version

Note:

Use insert RA110 in toolholder RB110
 Use insert LA110 in toolholder LB110

Face grooving with full width of the full depth only possible between D_{amin} .787" - 1.969".

FACE GROOVING



B

INSERT Type

A110

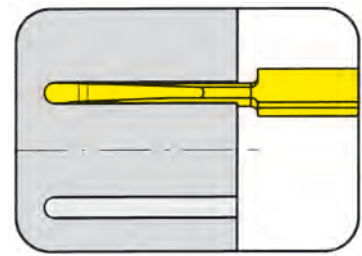

from outer groove \varnothing .787"
 Depth of groove up to 1.181"
 Width of groove up to .118"

for use with Toolholder

Type B110...16.2
 BU110...16.2

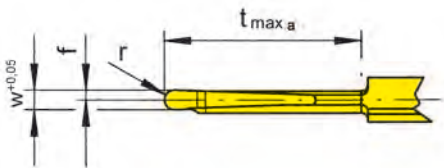
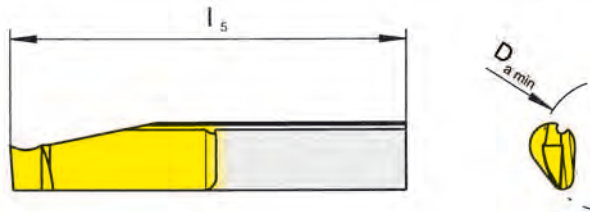

L = left hand version shown

R = right hand version

Full radius

Part number	w	f	l ₅	t _{max a}	D _{a min}	r	Carbide grades					
							MG12	TN35	TI25	TF45	TH35	
R/LA110.2030.15.5.0	.118	.059	2.362	1.181	.787	.059		▲/▲				
▲ on stock Δ 4 weeks												
● main recommendation												
○ alternative recommendation												
□ uncoated grades												
■ coated grades												
■ brazed/Cermet												

Dimensions in inch

State R or L version

Note:

Use insert RA110 in toolholder RB110
 Use insert LA110 in toolholder LB110

Face grooving with full width of the full depth only possible between D_{amin} .787" - 1.969".

HCG - HORN Catalog Guide

Bore Ø	Product line								
	105	110	108	10P	111	11P	114	116	18P
≥ .008" (0.2 mm)	•								
≥ .236" (6.0 mm)	•	•							
≥ .268" (6.8 mm)	•	•							
≥ .307" (7.8 mm)		•	•						
≥ .315" (8.0 mm)		•	•						
≥ .346" (8.8 mm)				•					
≥ .354" (9.0 mm)		•	•	•					
≥ .386" (9.8 mm)					•	•			
≥ .394" (10.0 mm)		•		•	•				
≥ .419" (10.5 mm)						•			
≥ .433" (11.0 mm)					•	•			
≥ .492" (12.5 mm)							•		
≥ .551" (14.0 mm)							•	•	
≥ .630" (16.0 mm)								•	
≥ .650" (16.5 mm)							•		
≥ .689" (17.5 mm)									•

Groove depth ≤ (inch)	.098"	.157"	.039"	.118"	.091"	.138"	.256"	.169"	.315"
Groove depth ≤ (mm)	2.5	4.0	1.0	3.0	2.3	3.5	6.5	4.3	8.0
Width of groove inch	.020"-.079"	.039"-.250"	.029"-.079"	.039"-.118"	.029"-.125"	.039"-.118"	.029"-.125"	.029"-.157"	.071"-.118"
Width of groove mm	0.5 - 2.0	1.0 - 6.35	0.74 - 2.0	1.0 - 3.0	0.74 - 3.18	1.0 - 3.0	0.74 - 3.18	0.74 - 4.0	1.8 - 3.0

Application	Product line								
	105	110	108	10P	111	11P	114	116	18P
Grooving	•	•	•	•	•	•	•	•	•
Boring	•	•	•	•	•	•	•	•	•
Threading	•		•		•		•	•	
Chamfering	•		•		•		•	•	
Face Grooving	•	•					•		
Hard turning	•		•		•		•	•	

Chapter	A	B	C	D	E	F	G	H	J
---------	----------	----------	----------	----------	----------	----------	----------	----------	----------

Special tools upon request

MINI CARBIDE GROOVING TOOLS

Toolholder
BU108 / B108



Page C2-C5

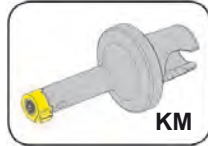

Page C6-C7

Inserts
U108 / 108 / S108
≥ Ø .315" (8.0 mm)

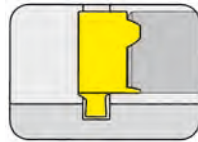

Page C8-C9

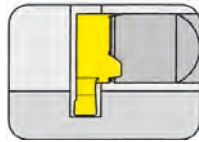

Page C10-C14

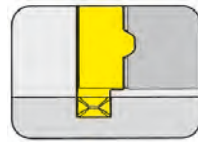

Page C15

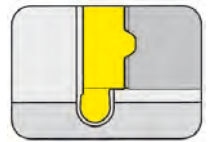

Page C16-C17

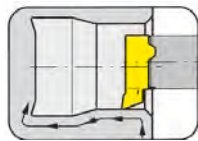

Page C18-C20

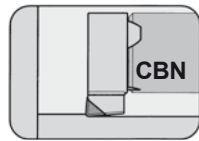

Page C21

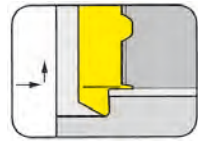

Page C23

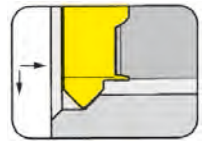

Page C24

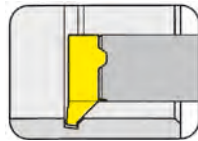

Page C25

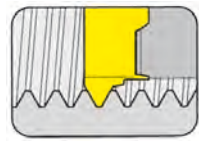

Page C26-C27

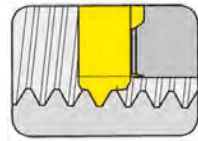

Page C28-C29

Technical Instructions Page L1 - L9

TOOLHOLDER Type

BU108

with through coolant supply

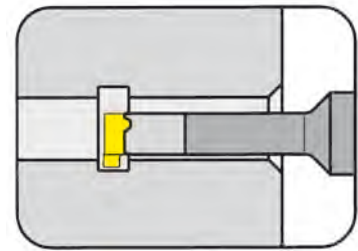

C

Bore Ø from	.315"
Depth of groove up to	.039"
Width of groove up to	.079"

Material of shank: Carbide - Giving a good vibration resistance

for use with Insert

Type 108
S108
U108

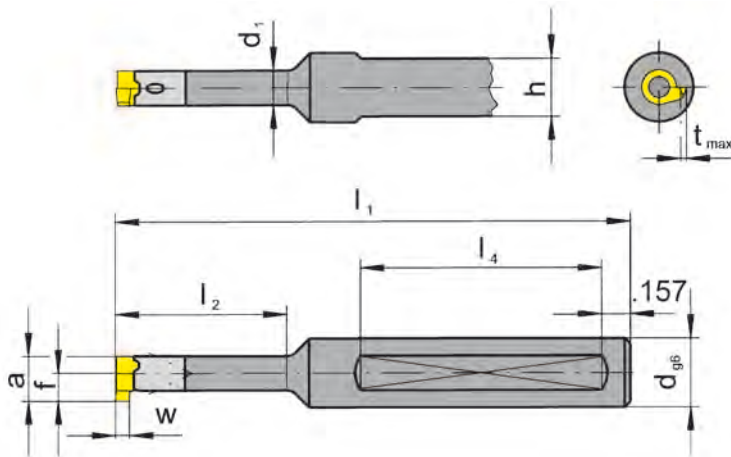

Picture = right hand cutting version shown

Part number	d	l ₁	l ₂	h	l ₄	d ₁	Remark
BU108.ST05.00	.500	2.756	.492	.460	1.570	.236	* Steel Toolholder
BU108.0500.01		3.150	.827				
BU108.0500.02	.500	3.543	1.181	.460	1.770	.236	
BU108.0500.03		3.937	1.654				

Further sizes upon request

w, a, t_{max} and f see inserts

Dimensions in inch

Ordering note:

Toolholders can be used in right and left hand inserts.
Toolholders with damaged seating can be repaired by HORN.

* Steel toolholder is not repairable.

Spare parts

Toolholder	Screw	TORX PLUS® Wrench
BU108....	2.6.5T8EP	T8PL

TOOLHOLDER Type

B108

with through coolant supply

Bore Ø from	.315" (8.0 mm)
Depth of groove up to	.039" (1.0 mm)
Width of groove up to	.079" (2.0 mm)

Material of shank: Carbide - Giving a good vibration resistance

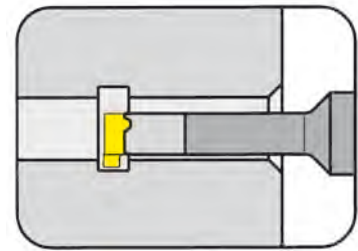

for use with Insert

Type 108
S108
U108

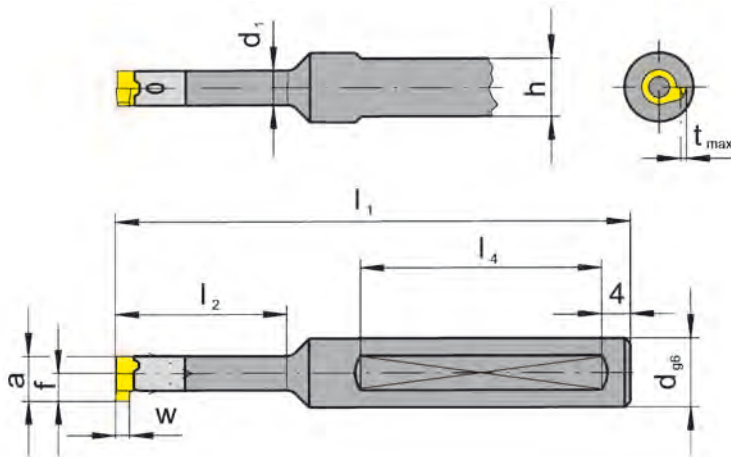

Picture = right hand cutting version shown

Part number	d	l ₁	l ₂	h	l ₄	d ₁
B108.0008.00	8	60	12.5	7	35	6
B108.0008.01		70	21.0		40	
B108.0012.00	12	70	12.5	11	40	6
B108.0012.01		80	21.0		45	
B108.0012.02		90	30.0		45	
B108.0012.03		100	42.0		45	

Further sizes upon request

w, a, t_{max} and f see inserts

Dimensions in mm

Ordering note:

Toolholders can be used in right and left hand inserts.
Toolholders with damaged seating can be repaired by HORN.

Spare parts

Toolholder	Screw	TORX PLUS® Wrench
B108.00...	2.6.5T8EP	T8PL

TOOLHOLDER Type

B108

with through coolant supply

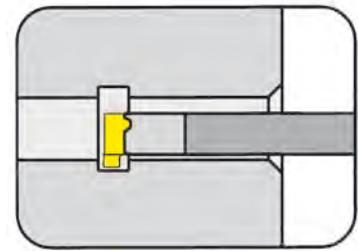

Bore Ø from	.315" (8.0 mm)
Depth of groove up to	.039" (1.0 mm)
Width of groove up to	.079" (2.0 mm)

Material of shank: Carbide - Giving a good vibration resistance

for use with Insert

Type 108
S108
U108

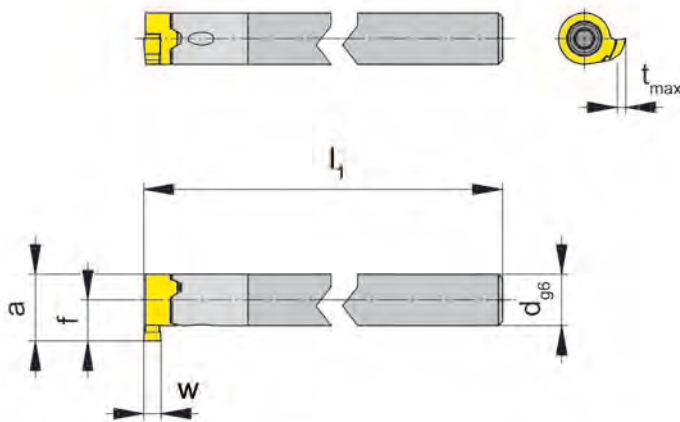

Picture = right hand cutting version shown

Part number	d	l ₁
B108.0006.01A	6	65

Further sizes upon request

w, a, t_{max} and f see inserts

Dimensions in mm

Ordering note:

Toolholders can be used in right and left hand inserts.
Toolholders with damaged seating can be repaired by HORN.

Spare parts

Toolholder	Screw	TORX PLUS® Wrench
B108.0006.01A	2.6.5T8EP	T8PL

TOOLHOLDER Type

B108

with through coolant supply

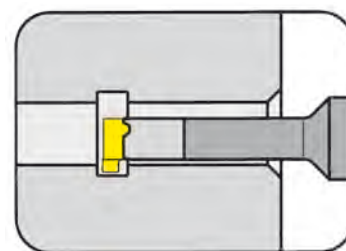

Bore Ø from	.315" (8.0 mm)
Depth of groove up to	.039" (1.0 mm)
Width of groove up to	.079" (2.0 mm)

Material of shank: Carbide - Giving a good vibration resistance

for use with Insert

Type 108
S108
U108

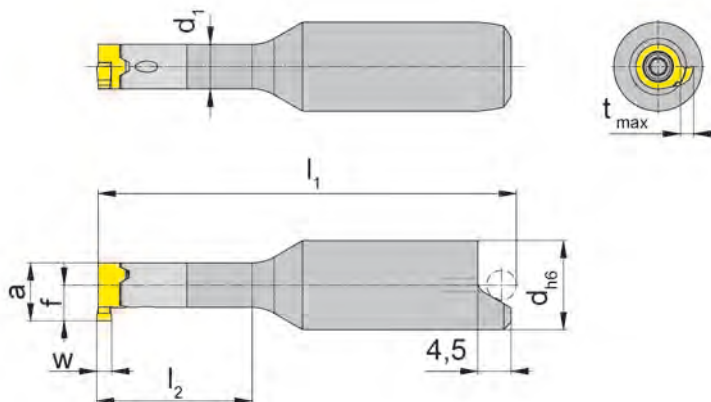

Picture = right hand cutting version shown

for shrinkage location
S = orientation

Part number	d	l ₁	l ₂	d ₁
B108.0012.00S	12	48.7	12.5	6
B108.0012.01S		56.7	21.0	
B108.0012.02S		65.7	30.0	
B108.0012.03S		77.7	42.0	

Further sizes upon request

w, a, t_{max} and f see inserts

Dimensions in mm

Ordering note:

Toolholders can be used in right and left hand inserts.
Toolholders with damaged seating can be repaired by HORN.

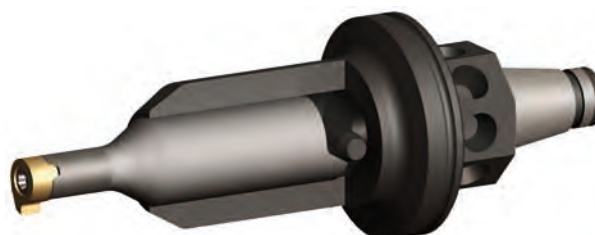

Example of assembly System „W&F“

Spare parts

Toolholder	Screw	TORX PLUS® Wrench
B108.0012.0...	2.6.5T8EP	T8PL

TOOLHOLDER Type

B108KM

with through coolant supply

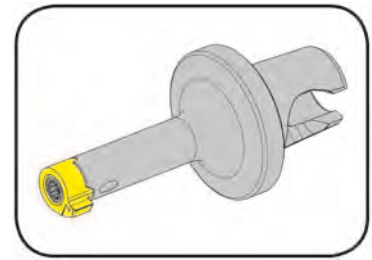

Bore Ø from

.315" (8.0 mm)

for use with Insert

Type 108
S108
U108

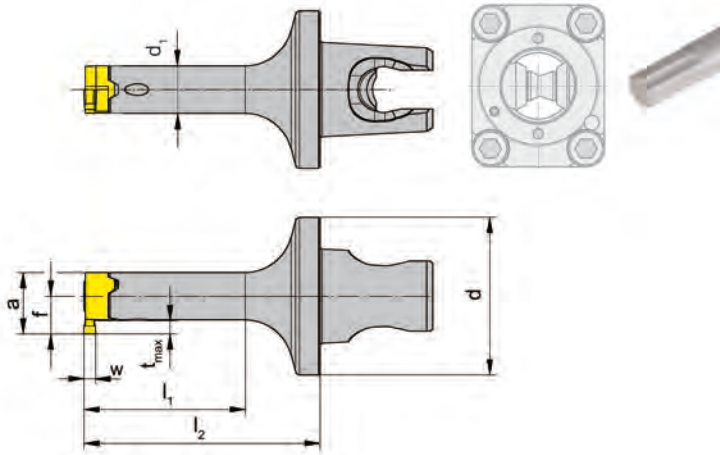

System Kennametal
KM16 Micro

Part number	d	l ₁	l ₂	d ₁
B108.KM16.01	20	21	30	6
B108.KM16.02		26	35	

Further sizes upon request

w, a, t_{max} and f see inserts

Dimensions in mm

Spare parts

Toolholder	Screw	TORX PLUS® Wrench
B108.KM16.0...	2.6.5T8EP	T8PL

TOOLHOLDER Type

B108KM

with through coolant supply

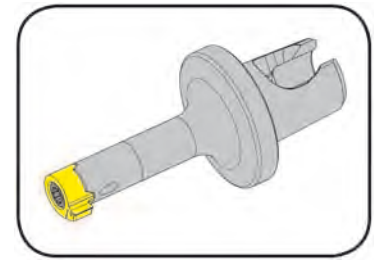

Bore Ø from .315" (8.0 mm)

for use with Insert

Type 108
S108
U108

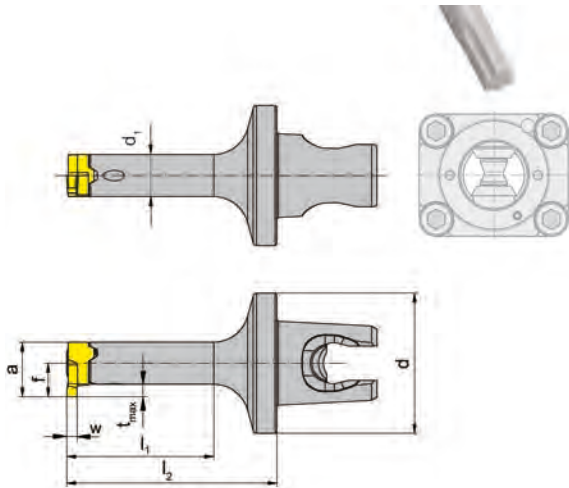

System Kennametal
KM16 Micro

Part number	d	l ₁	l ₂	d ₁
B108.KM16.90.01	20	21	30	6
B108.KM16.90.02		26	35	

Further sizes upon request

w, a, t_{max} and f see inserts

Dimensions in mm

Spare parts

Toolholder	Screw	TORX PLUS® Wrench
B108.KM16.90.0...	2.6.5T8EP	T8PL

GROOVING (internal) $\geq \text{Ø} .315''$



INSERT Type

U108

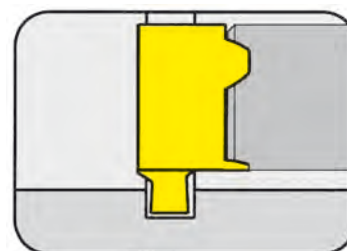

for use with Toolholder

Type B108
B108KM
BU108

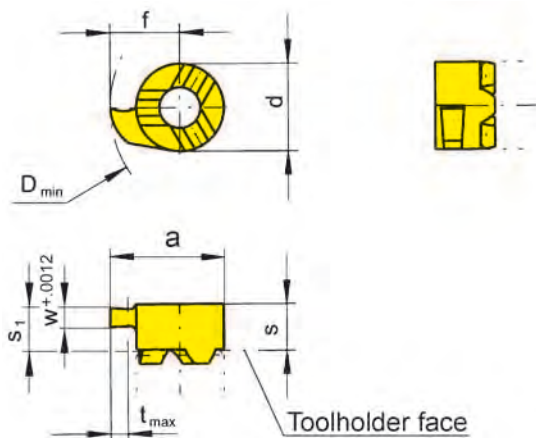

R = right hand version

L = left hand version

not face cutting,
limited depth of cut

Part number	w	s ₁	s	f	a	d	t _{max}	D _{min}	Carbide grades					
									MG12	TN35	TI25	TF45	TH35	
R/LU108.0031.00	.031							.315	Δ/	▲/▲				
R/LU108.0039.00	.039	.126	.142	.189	.307	.236	.039		▲/	▲/				
									P	o	•			
									M	•	•			
									K	•	•			
									S	•	•			
									N	•	•			
									H					

- ▲ on stock Δ 4 weeks
- main recommendation
- o alternative recommendation
- uncoated grades
- coated grades
- brazed/Cermet

Dimensions in inch

State R or L version

Carbide grades

GROOVING (internal) $\geq \text{Ø} .315''$



INSERT Type

108

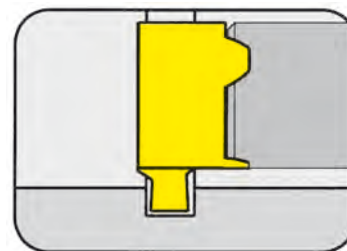

Bore Ø from	.315"
Depth of groove up to	.039"
Width of circlip Nw	.028 - .035"

Widths for circlip grooves DIN 471/472

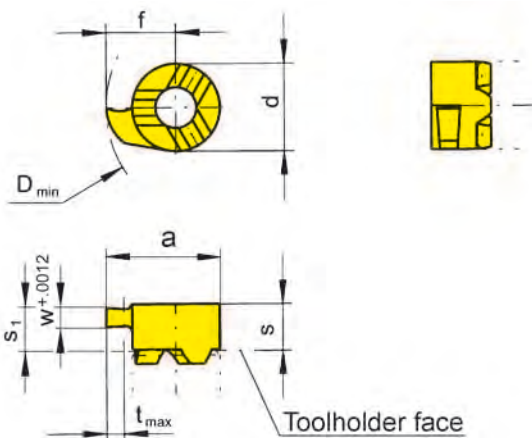

for use with Toolholder

Type B108
B108KM
BU108

not face cutting,
limited depth of cut

R = right hand version shown

L = left hand version

Part number	Nw	w	s ₁	s	f	a	d	t _{max}	D _{min}	Carbide grades					
										MG12	TN35	TI25	TF45	TH35	
R/L108.0070.00	.028	.029									▲/▲			▲/▲	
R/L108.0080.00	.031	.033	.126	.142	.189	.307	.236	.039	.315		▲/▲			▲/▲	
R/L108.0090.00	.035	.037									▲/▲			▲/▲	
											P	•			•
											M	•			•
											K	•			•
											S	•			•
											N	•			•
											H				

- ▲ on stock Δ 4 weeks
- main recommendation
- o alternative recommendation
- uncoated grades
- coated grades
- brazed/Cermet

Dimensions in inch
State R or L version

Carbide grades

NC-PROFILING (internal) $\geq \text{Ø } .315''$



INSERT Type

U108

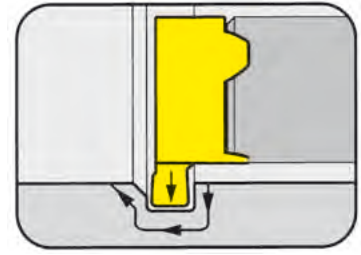

Bore Ø from	.315"
Depth of groove up to	.039"
Width of groove	.031 - .078"

for use with Toolholder

Type B108
B108KM
BU108

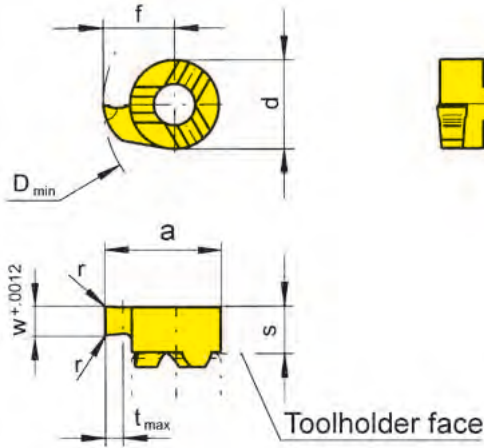

R = right hand version shown

L = left hand version

with corner radius

Part number	w	r	s	f	a	d	t _{max}	D _{min}	MG12	TN35	TI25	TF45	TH35
R/LU108.0031.08	.031								▲/	▲/			
R/LU108.0046.08	.046									▲/▲			
R/LU108.0062.08	.062	.008	.126	.189	.307	.236	.039	.315		▲/▲	▲/		
R/LU108.0078.08	.078									▲/▲			
									P	o	•	•	
									M	•	•	•	
									K	•	•	•	
									S	•	•	•	
									N	•	•	•	
									H				

- ▲ on stock Δ 4 weeks
- main recommendation
- o alternative recommendation
- uncoated grades
- coated grades
- brazed/Cermet

Dimensions in inch

State R or L version

Carbide grades

NC-PROFILING (internal) $\geq \text{Ø} .315''$



INSERT Type

108

Bore Ø from	.315"
Depth of groove up to	.039"
Width of groove	.059"

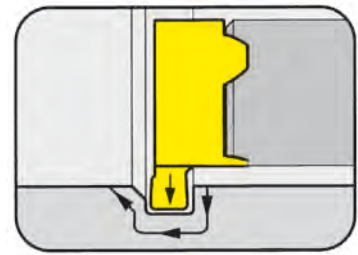

C

for use with Toolholder

Type B108
B108KM
BU108

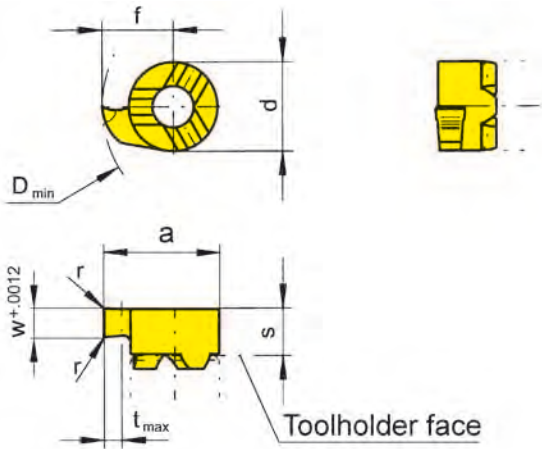

R = right hand version shown

L = left hand version

with corner radius

Part number	w	r	s	f	a	d	t _{max}	D _{min}	MG12	TN35	TI25	TF45	TH35
R/L108.0150.02	.059	.008	.126	.189	.307	.236	.039	.315	▲/▲	▲/▲	▲/▲		▲/▲
									P	o	•	•	•
									M	•	•	•	•
									K	•	•	•	•
									S	•	•	•	•
									N	•	•	•	•
									H				

Carbide grades

- ▲ on stock Δ 4 weeks
- main recommendation
- o alternative recommendation
- uncoated grades
- coated grades
- brazed/Cermet

Dimensions in inch

State R or L version

GROOVING (internal) $\geq \text{Ø} .315''$



INSERT Type

U108

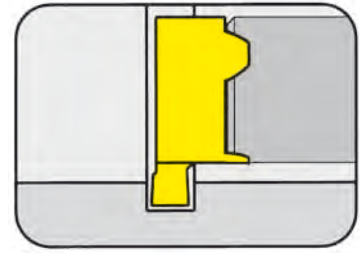

for use with Toolholder

Type B108
B108KM
BU108

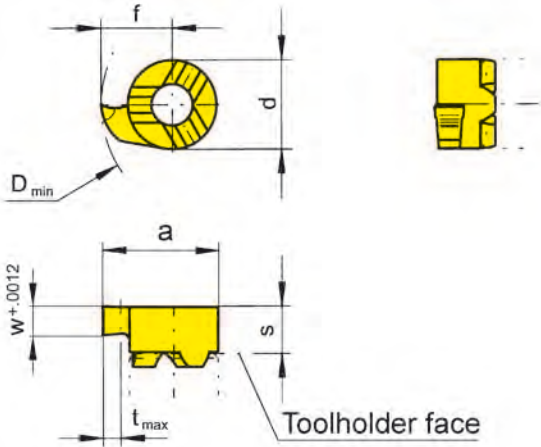

R = right hand version shown

L = left hand version

Part number	w	s	f	a	d	t _{max}	D _{min}	Carbide grades				
								MG12	TN35	TI25	TF45	TH35
R/LU108.0046.00	.046							▲/	▲/			
R/LU108.0056.00	.056							▲/▲	▲/▲			
R/LU108.0062.00	.062	.126	.189	.307	.236	.039	.315	▲/	▲/▲			
R/LU108.0078.00	.078							▲/▲	▲/▲			
								P	o	•		
								M	•	•		
								K	•	•		
								S	•	•		
								N	•	•		
								H				

- ▲ on stock Δ 4 weeks
- main recommendation
- o alternative recommendation
- uncoated grades
- coated grades
- brazed/Cermet

Dimensions in inch

State R or L version

Carbide grades

GROOVING (internal) $\geq \text{Ø} .315''$



INSERT Type

108

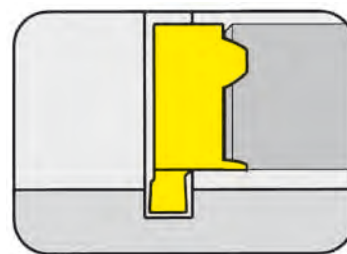

Bore Ø from	.315"
Depth of groove up to	.039"
Width of circlip Nw	.043 - .063"

Widths for circlip grooves DIN 471/472

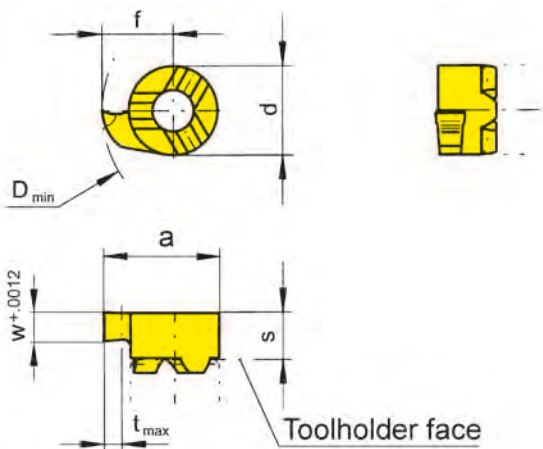

for use with Toolholder

Type B108
B108KM
BU108

R = right hand version shown

L = left hand version

Part number	Nw	w	s	f	a	d	t _{max}	D _{min}	MG12	TN35	TI25	TF45	TH35	
R/L108.0110.00	.043	.047							▲/▲	▲/▲			▲/▲	
R/L108.0130.00	.051	.055	.126	.189	.307	.236	.039	.315	▲/▲	▲/▲			▲/▲	
R/L108.0160.00	.063	.067							▲/▲	▲/▲			▲/▲	
										P	o	•	•	•
										M	•	•	•	•
										K	•	•	•	•
										S	•	•	•	•
										N	•	•	•	•
										H				

- ▲ on stock Δ 4 weeks
- main recommendation
- o alternative recommendation
- uncoated grades
- coated grades
- brazed/Cermet

Dimensions in inch
State R or L version

Carbide grades

GROOVING (internal) $\geq \text{Ø} .315''$



INSERT Type

108

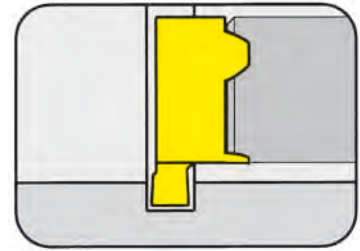

for use with Toolholder

Type B108
B108KM
BU108

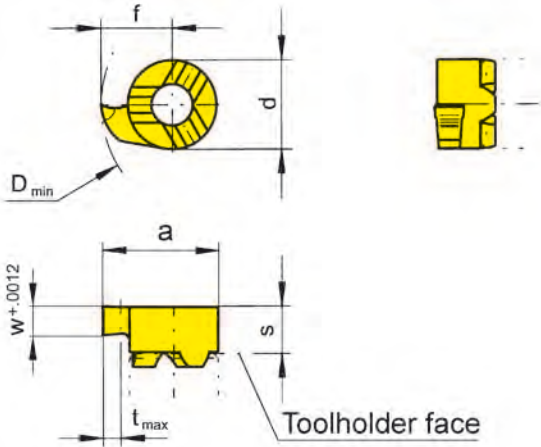

R = right hand version shown

L = left hand version

Part number	w	s	f	a	d	t _{max}	D _{min}	MG12	TN35	TI25	TF45	TH35
R/L108.0150.00	.059	.126	.189	.307	.236	.039	.315	▲/▲	▲/▲			▲/▲
R/L108.0200.00	.079	.126	.189	.307	.236	.039	.315	▲/▲	▲/▲			▲/▲
								P	o	•		•
								M	•	•		•
								K	•	•		•
								S	•	•		•
								N	•	•		•
								H				

- ▲ on stock Δ 4 weeks
- main recommendation
- o alternative recommendation
- uncoated grades
- coated grades
- brazed/Cermet

Carbide grades

Dimensions in inch

State R or L version

GROOVING (internal) $\geq \text{Ø} .315''$



INSERT Type

S108

Bore Ø from	.315"
Depth of groove up to	.039"
Width of groove	.039 - .079"

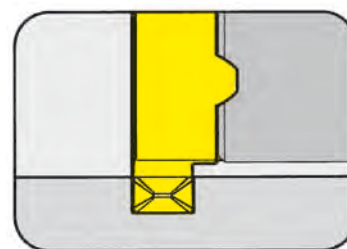

for use with Toolholder

Type B108
B108KM
BU108

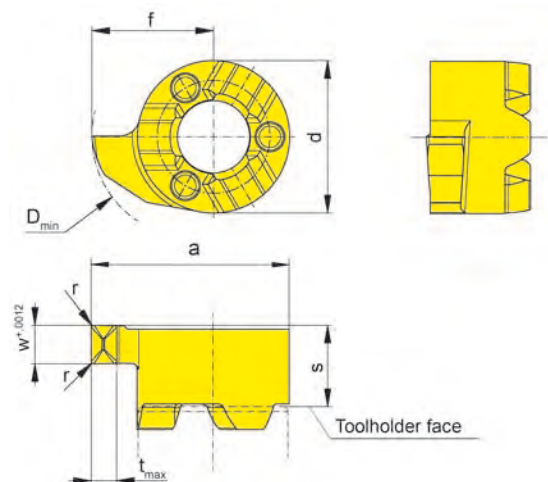

R = right hand version shown

L = left hand version

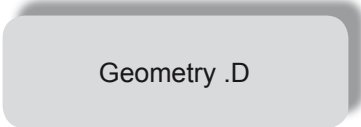

Part number	w	r	s	f	a	d	t _{max}	D _{min}	Carbide grades				
									MG12	TN35	TI25	TF45	TH35
R/LS108.0100.D1	.039	.004											▲▲
R/LS108.0150.D1	.059	.004	.126	.189	.307	.236	.039	.315					▲▲
R/LS108.0200.D2	.079	.008											▲▲
									P				•
									M				•
									K				•
									S				•
									N				•
									H				•

- ▲ on stock Δ 4 weeks
- main recommendation
- o alternative recommendation
- uncoated grades
- coated grades
- brazed/Cermet

Dimensions in inch

State R or L version

Carbide grades

GROOVING (internal) $\geq \text{Ø} .315''$



INSERT Type

U108

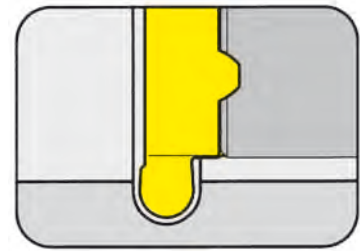

Bore Ø from	.315"
Depth of groove up to	.039"
Width of groove	.031 - .078"

for use with Toolholder

Type B108
B108KM
BU108

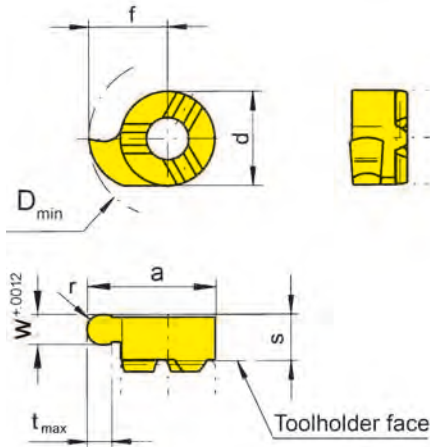

R = right hand version shown

L = left hand version

Full radius

Part number	w	r	s	f	a	d	t _{max}	D _{min}	Carbide grades				
									MG12	TN35	TI25	TF45	TH35
R/LU108.0015.31	.031	.015							▲/▲	▲/			
R/LU108.0023.46	.046	.023							▲/▲				
R/LU108.0031.62	.062	.031	.126	.189	.307	.236	.039	.315	▲/	▲/▲			
R/LU108.0039.78	.078	.039							▲/▲		▲/		
									P	o	•	•	•
									M	•	•	•	•
									K	•	•	•	•
									S	•	•	•	•
									N	•	•	•	•
									H				

- ▲ on stock Δ 4 weeks
- main recommendation
- o alternative recommendation
- uncoated grades
- coated grades
- brazed/Cermet

Dimensions in inch

State R or L version

Carbide grades

GROOVING (internal) $\geq \text{Ø} .315''$



INSERT Type

108

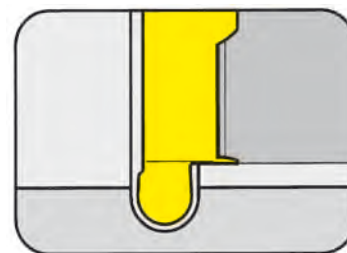

Bore Ø from	.315"
Depth of groove up to	.039"
Width of groove	.031 - .071"

for use with Toolholder

Type B108
B108KM
BU108

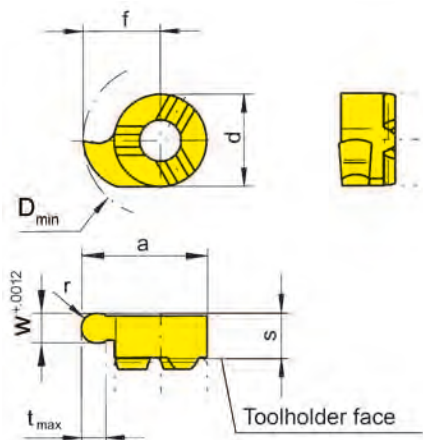

R = right hand version shown

L = left hand version

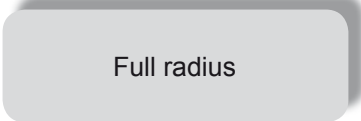

Part number	w	r	s	f	a	d	t _{max}	D _{min}	Carbide grades					
									MG12	TN35	TI25	TF45	TH35	
R/L108.0004.08	.031	.016							▲/Δ	▲/▲				▲/▲
R/L108.0006.12	.047	.024	.126	.189	.307	.236	.039	.315	▲/▲	▲/▲				▲/▲
R/L108.0009.18	.071	.035							▲/▲	▲/▲	▲/Δ			▲/▲
									P	o	•	•	•	•
									M	•	•	•	•	•
									K	•	•	•	•	•
									S	•	•	•	•	•
									N	•	•	•	•	•
									H					

- ▲ on stock Δ 4 weeks
- main recommendation
- o alternative recommendation
- uncoated grades
- coated grades
- brazed/Cermet

Dimensions in inch
State R or L version

Carbide grades

INSERT Type

108

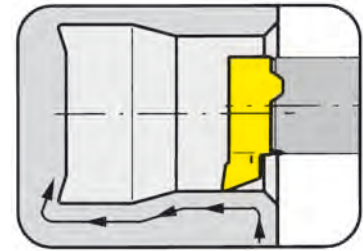

for use with Toolholder

Type B108
B108KM
BU108

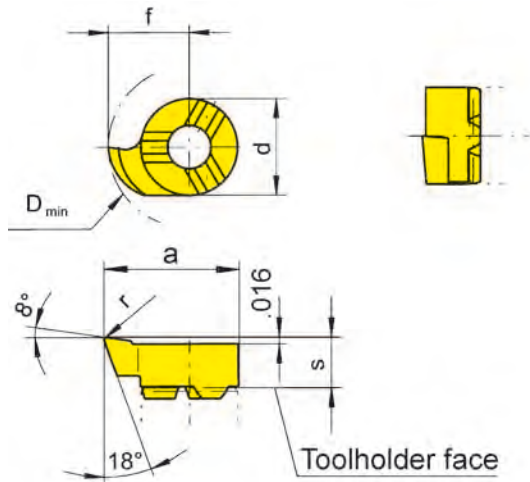

R = right hand version shown

L = left hand version

Part number	r	s	f	a	d	D _{min}	Carbide grades				
							MG12	TN35	TI25	TF45	TH35
R/L108.1846.02	.008	.134	.183	.301	.236	.307	▲/▲	▲/▲	▲/▲	▲/▲	▲/▲
▲ on stock Δ 4 weeks							P	o	•	•	•
• main recommendation							M	•	•	•	•
o alternative recommendation							K	•	•	•	•
■ uncoated grades							S	•	•	•	•
■ coated grades							N	•	•	•	•
■ brazed/Cermet							H				

Dimensions in inch

State R or L version

The modified geometry allows boring of bores $\geq \text{Ø} .307''$ and profiling of reliefs as per DIN 509 form E and .

INSERT Type

S108

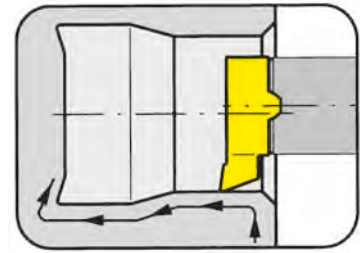

Bore Ø from $.307''$
 Depth of undercut up to $.051''$

for use with Toolholder

Type B108
 B108KM
 BU108

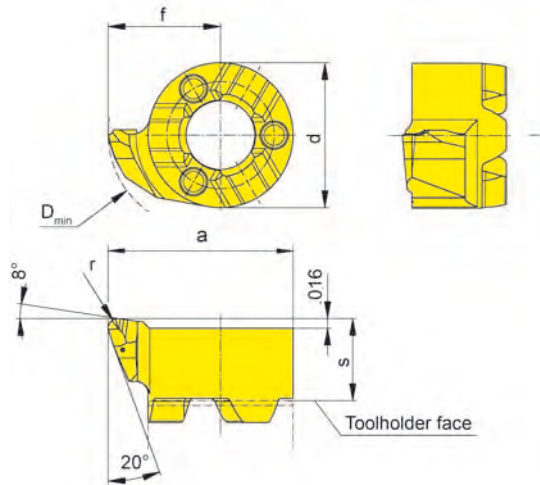

R = right hand version shown

L = left hand version

Geometry .R

Part number	r	s	f	a	d	D _{min}	Carbide grades				
							MG12	TN35	TI25	TF45	TH35
LS108.1846.R2	.008									▲	
RS108.1846.R2	.008					.307				▲	
LS108.1846.R4	.016	.134	.183	.301	.236					▲	
RS108.1846.R4	.016									▲	
							P			•	
							M			•	
							K			•	
							S			•	
							N			•	
							H			•	

- ▲ on stock Δ 4 weeks
- main recommendation
- o alternative recommendation
- uncoated grades
- coated grades
- brazed/Cermet

Dimensions in inch
 State R or L version

The modified geometry allows boring of bores $\geq \text{Ø} .307''$ and profiling of reliefs as per DIN 509 form E and F.

INSERT Type

108

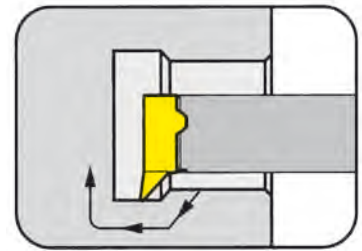

for use with Toolholder

Type B108
B108KM
BU108

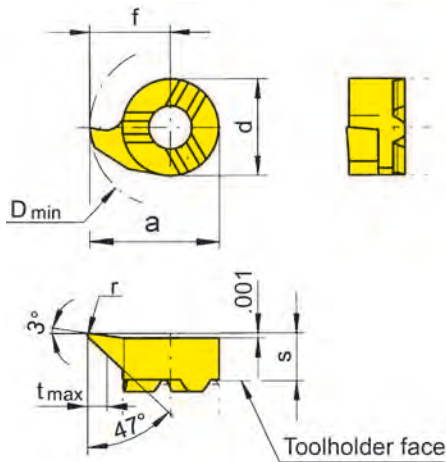

R = right hand version shown

L = left hand version

Part number	r	s	f	a	d	t _{max}	D _{min}	MG12	TN35	TI25	TF45	TH35
R/L108.4748.01	.004	.126	.183	.301	.236	.047	.307					▲/▲
R/L108.4748.02	.008	.126	.183	.301	.236	.047	.307		▲/▲			▲/▲
▲ on stock Δ 4 weeks								P	•	•	•	•
• main recommendation								M	•	•	•	•
o alternative recommendation								K	•	•	•	•
■ uncoated grades								S	•	•	•	•
■ coated grades								N	•	•	•	•
■ brazed/Cermet								H	•	•	•	•

Carbide grades

Dimensions in inch

State R or L version

The modified geometry allows boring of bores $\geq \text{Ø} .307''$ and profiling of reliefs as per DIN 509 form

INSERT Type

108

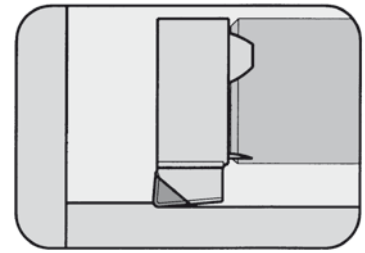

C

Bore Ø from .307"

for use with Toolholder

Type B108
B108KM
BU108

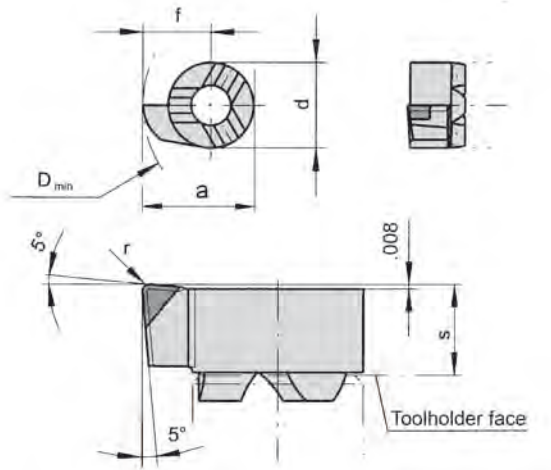

R = right hand version shown

CBN tipped

Part number	r	s	f	a	d	D _{min}		CB10
R108.0547.03.B	.012	.138	.183	.301	.236	.307		▲
								P
								M
								K
								S
								N
								H •

- ▲ on stock Δ 4 weeks
- main recommendation
- alternative recommendation
- uncoated grades
- coated grades
- brazed/Cermet

Dimensions in inch

Carbide grades

BROACHING on CNC lathes

C

BROACHING TOOLS TYPE SB105/SB110 and SH117

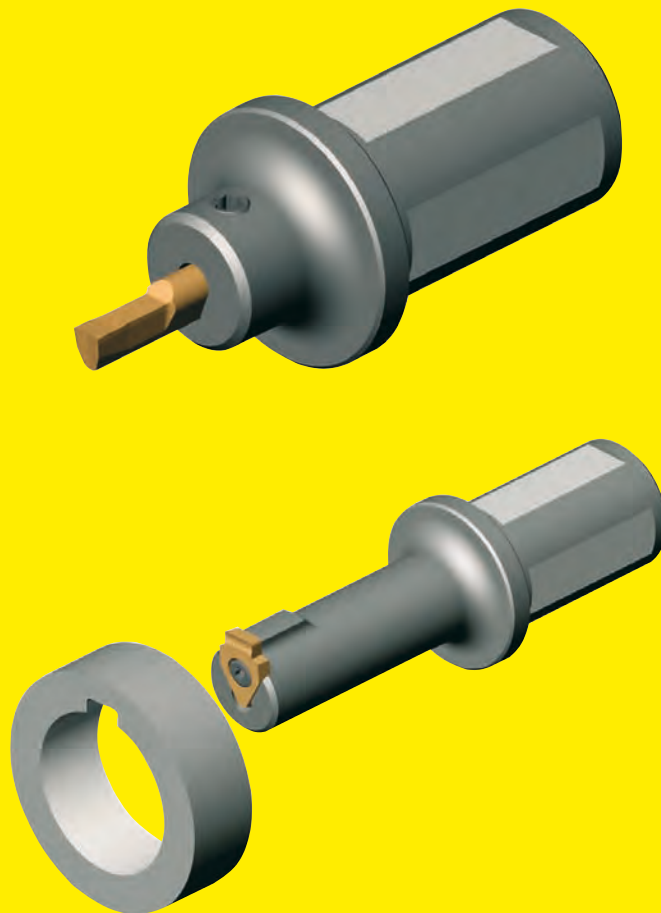

KEYWAYS ACCORDING DIN138 and DIN6885

For further information please see HORN catalog "CARBIDE GROOVING TOOLS".

BACKBORING (internal)



INSERT Type

108

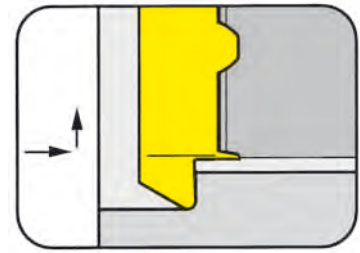

Bore Ø from .307"

for use with Toolholder

Type B108
B108KM
BU108

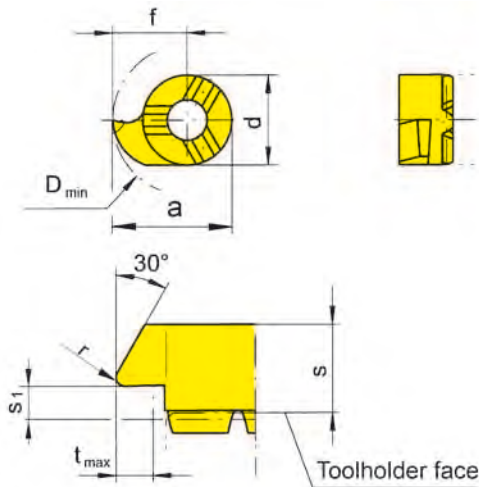

R = right hand version shown

L = left hand version

Part number	r	s ₁	s	f	a	d	t _{max}	D _{min}	Carbide grades				
									MG12	TN35	TI25	TF45	TH35
R/L108.3046.02	.008	.031	.142	.183	.301	.236	.051	.307		▲/▲			▲/▲
									P	•	•	•	•
									M	•	•	•	•
									K	•	•	•	•
									S	•	•	•	•
									N	•	•	•	•
									H				

- ▲ on stock Δ 4 weeks
- main recommendation
- o alternative recommendation
- uncoated grades
- coated grades
- brazed/Cermet

Dimensions in inch

State R or L version

CHAMFERING and BACKBORING (internal)



INSERT Type

108

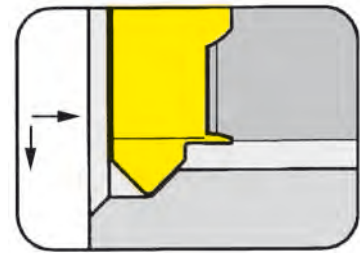

Bore Ø from .307"

for use with Toolholder

Type B108
B108KM
BU108

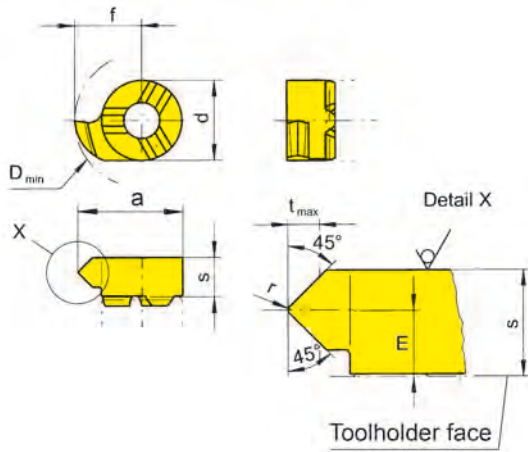

R = right hand version shown

L = left hand version

Part number	E	r	s	f	a	d	t _{max}	D _{min}	Carbide grades					
									MG12	TN35	TI25	TA45	TH35	
R/L108.4545.02	.071	.008	.142	.183	.301	.236	.055	.307		▲/▲	▲/▲	▲/		
▲ on stock Δ 4 weeks ● main recommendation ○ alternative recommendation □ uncoated grades ■ coated grades ■ brazed/Cermet										P	●	●	●	
										M	●	●	●	
										K	●	●	●	
										S	●	●	●	
										N	●	●	●	
										H				

Dimensions in inch

State R or L version

INSERT Type

108

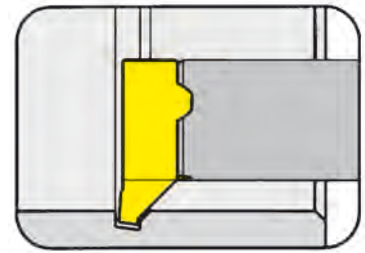

C

Bore Ø from .315"

for use with Toolholder

Type B108
B108KM
BU108

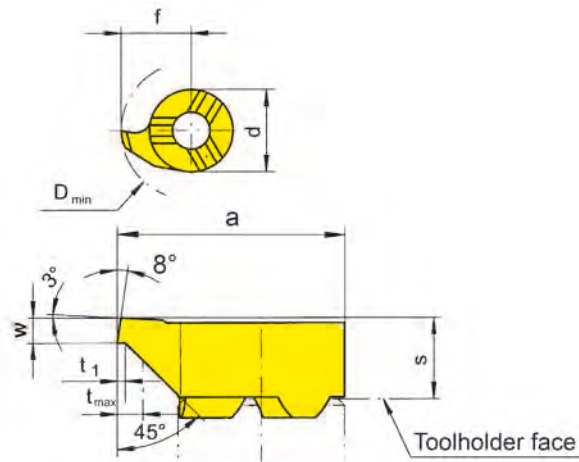

R = right hand version shown

L = left hand version

Part number	w	s	f	a	d	t ₁	t _{max}	D _{min}	Carbide grades				
									MG12	TN35	TI25	TF45	TH35
R/L108.0810.45	.039	.126	.189	.307	.236	.008	.059	.315	▲/▲	▲/▲	▲/▲		
▲ on stock Δ 4 weeks									P	o	•	•	
• main recommendation									M	•	•	•	
o alternative recommendation									K	•	•	•	
■ uncoated grades									S	•	•	•	
■ coated grades									N	•	•	•	
■ brazed/Cermet									H				

Dimensions in inch

State R or L version

Carbide grades

THREADING (internal) Partial profile



INSERT Type

108

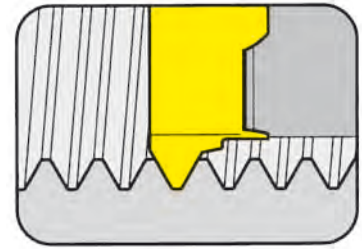

for use with Toolholder

Type B108
B108KM
BU108

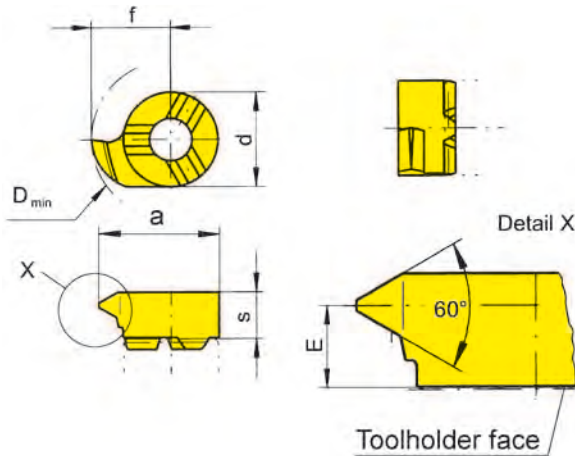

R = right hand version shown

L = left hand version

Metric ISO standard thread

Part number	P	P _{max}	E	s	f	a	d	D _{min}	Carbide grades				
									MG12	TN35	TI25	TF45	TH35
R/L108.0815.01	1.5	1.75	2.6	3.6	4.8	7.8	6	8	▲/▲	▲/▲			▲/▲
									P	○	●		●
									M	●	●		●
									K	●	●		●
									S	●	●		●
									N	●	●		●
									H				

- ▲ on stock Δ 4 weeks
- main recommendation
- alternative recommendation
- uncoated grades
- coated grades
- brazed/Cermet

Dimensions in mm

State R or L version

Carbide grades

THREADING (internal) Partial profile



INSERT Type

108

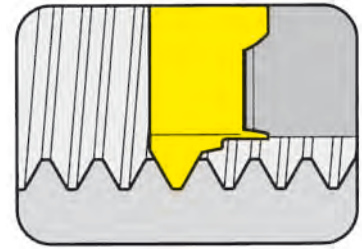

Bore Ø from Pitch	.315" (8.0 mm) 0.50 - 1.25 mm
-------------------	----------------------------------

for use with Toolholder

Type B108
B108KM
BU108

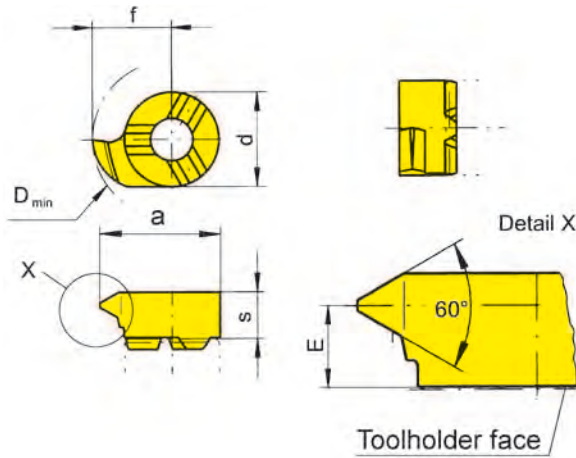

R = right hand version shown

L = left hand version

Metric ISO fine thread

Part number	P	P _{max}	E	s	f	a	d	D _{min}	Carbide grades					
									MG12	TN35	TI25	TF45	TH35	
R/L108.0205.01	0.5	0.75	2.8	3.6	4.8	7.8	6	8	▲/▲	▲/▲	●	●	●	●
R/L108.0510.01	1.0	1.25	2.8	3.6	4.8	7.8	6	8	▲/▲	▲/▲	▲/▲	●	●	●
									P	○	●	●	●	●
									M	●	●	●	●	●
									K	●	●	●	●	●
									S	●	●	●	●	●
									N	●	●	●	●	●
									H	●	●	●	●	●

- ▲ on stock Δ 4 weeks
- main recommendation
- alternative recommendation
- uncoated grades
- coated grades
- brazed/Cermet

Dimensions in mm

State R or L version

Carbide grades

THREADING (internal) Full profile



INSERT Type

108

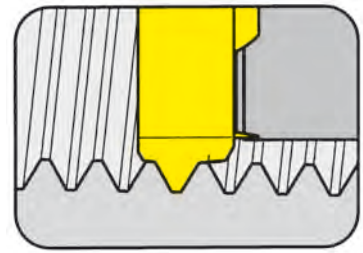

for use with Toolholder

Type B108
BU108

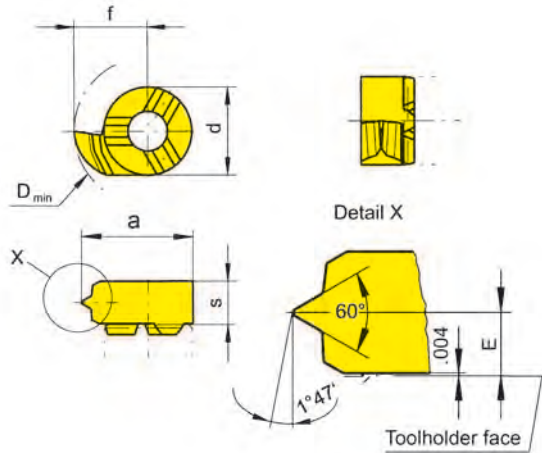

R = right hand version shown

Thread NPT

Part number	Threads per Inch	E	s	f	a	d	D _{min}	Carbide grades				
								MG12	TN35	TI25	TF45	TH35
R108.NP14.02	14							▲				
R108.NP18.02	18	.075	.142	.189	.307	.236	.315	▲				
R108.NP27.02	27							▲				
								P	•			
								M	•			
								K	•			
								S	•			
								N	•			
								H				

- ▲ on stock Δ 4 weeks
- main recommendation
- o alternative recommendation
- uncoated grades
- coated grades
- brazed/Cermet

Dimensions in inch

Carbide grades

THREADING (internal) Full profile



INSERT Type

108

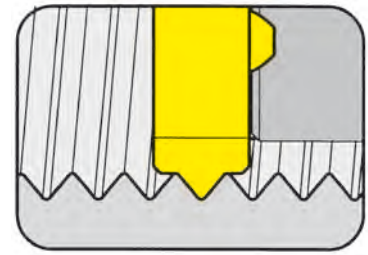

Threads per inch	18 / 20
------------------	---------

for use with Toolholder

Type B108
BU108

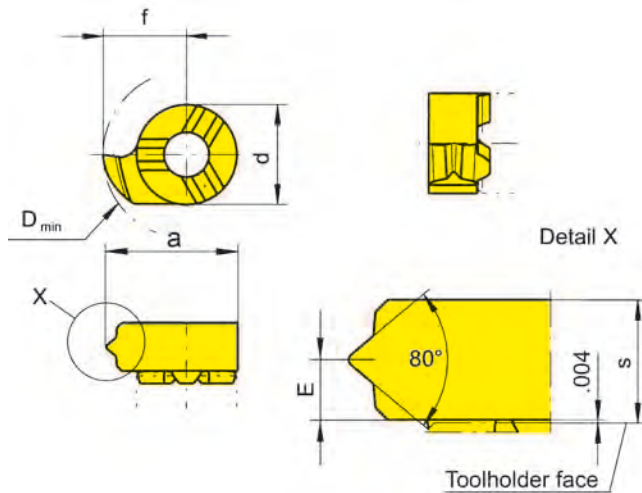

R = right hand version shown

Thread profile PG

Part number	Threads per Inch	E	s	f	a	d	D _{min}	Carbide grades				
								MG12	TN35	TI25	TF45	TH35
R108.PG18.02	18	.075	.142	.189	.307	.236	.315		▲			
R108.PG20.02	20							▲				
								●	●	●	●	●
								○	○	○	○	○
								■	■	■	■	■
								■	■	■	■	■
								■	■	■	■	■
								■	■	■	■	■

Dimensions in inch

Carbide grades

- ▲ on stock Δ 4 weeks
- main recommendation
- alternative recommendation
- uncoated grades
- coated grades
- brazed/Cermet

HCG - HORN Catalog Guide

Bore Ø	Product line								
	105	110	108	10P	111	11P	114	116	18P
≥ .008" (0.2 mm)	•								
≥ .236" (6.0 mm)	•	•							
≥ .268" (6.8 mm)	•	•							
≥ .307" (7.8 mm)		•	•						
≥ .315" (8.0 mm)		•	•						
≥ .346" (8.8 mm)				•					
≥ .354" (9.0 mm)		•	•	•					
≥ .386" (9.8 mm)					•	•			
≥ .394" (10.0 mm)		•		•	•				
≥ .419" (10.5 mm)						•			
≥ .433" (11.0 mm)					•	•			
≥ .492" (12.5 mm)							•		
≥ .551" (14.0 mm)							•	•	
≥ .630" (16.0 mm)								•	
≥ .650" (16.5 mm)							•		
≥ .689" (17.5 mm)									•

Groove depth ≤ (inch)	.098"	.157"	.039"	.118"	.091"	.138"	.256"	.169"	.315"
Groove depth ≤ (mm)	2.5	4.0	1.0	3.0	2.3	3.5	6.5	4.3	8.0
Width of groove inch	.020"-.079"	.039"-.250"	.029"-.079"	.039"-.118"	.029"-.125"	.039"-.118"	.029"-.125"	.029"-.157"	.071"-.118"
Width of groove mm	0.5 - 2.0	1.0 - 6.35	0.74 - 2.0	1.0 - 3.0	0.74 - 3.18	1.0 - 3.0	0.74 - 3.18	0.74 - 4.0	1.8 - 3.0

Application	Product line								
	105	110	108	10P	111	11P	114	116	18P
Grooving	•	•	•	•	•	•	•	•	•
Boring	•	•	•	•	•	•	•	•	•
Threading	•		•		•		•	•	
Chamfering	•		•		•		•	•	
Face Grooving	•	•					•		
Hard turning	•		•		•		•	•	

Chapter	A	B	C	D	E	F	G	H	J
---------	----------	----------	----------	----------	----------	----------	----------	----------	----------

Special tools upon request

MINI CARBIDE GROOVING TOOLS

Toolholder
BU10P / B10P



Page D2-D5

Inserts
10P / S10P
≥ Ø .354" (9.0 mm)

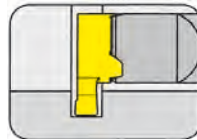

Page D6, D8

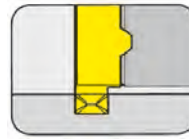

Page D7, D9

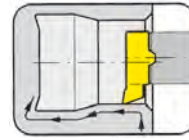

Page D10

D

Technical Instructions

Page L1 - L9

TOOLHOLDER Type

BU10P

with through coolant supply

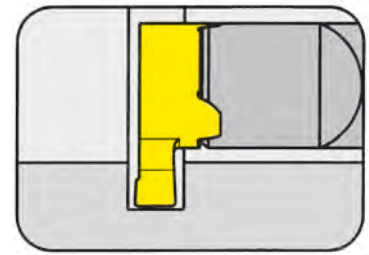

Bore Ø from	.354"
Depth of groove up to	.118"
Width of groove up to	.118"

Material of shank: Carbide - Giving a good vibration resistance

for use with Insert

Type 10P
S10P

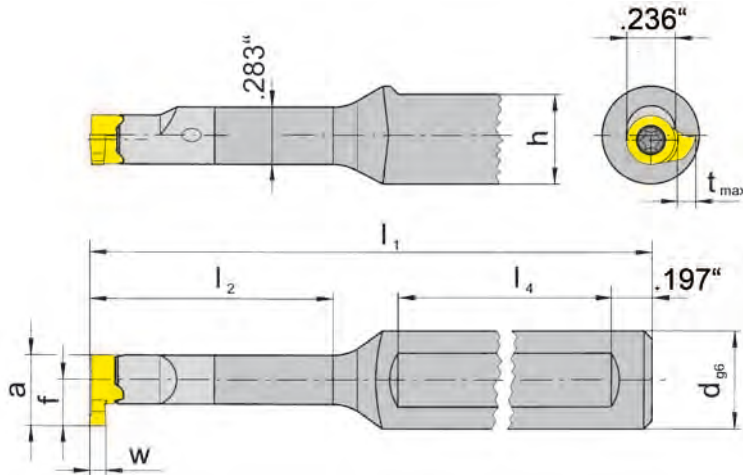

R = right hand version shown

L = left hand version

Part number	d	l ₁	l ₂	h	l ₄
R/LBU10P.0500.00		2.756	.492		1.575
R/LBU10P.0500.01	.500	3.150	.827	.461	1.772
R/LBU10P.0500.02		3.543	1.181		1.772

State R or L version

w, a, t_{max} and f see inserts

Dimensions in inch

Further sizes upon request

Ordering note:

Toolholders with damaged seating can be repaired by HORN.

Spare parts

Toolholder	Screw	TORX PLUS® Wrench
R/LBU10P.0500.0...	2.6.5T8EP	T8PL

TOOLHOLDER Type

B10P

with through coolant supply

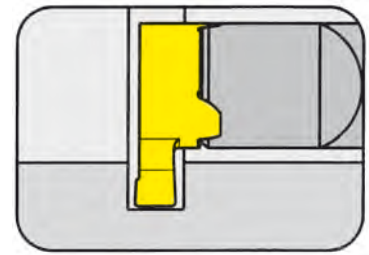

Bore Ø from	.354" (9.0 mm)
Depth of groove up to	.118" (3.0 mm)
Width of groove up to	.118" (3.0 mm)

Material of shank: Carbide - Giving a good vibration resistance

for use with Insert

Type 10P
S10P

D

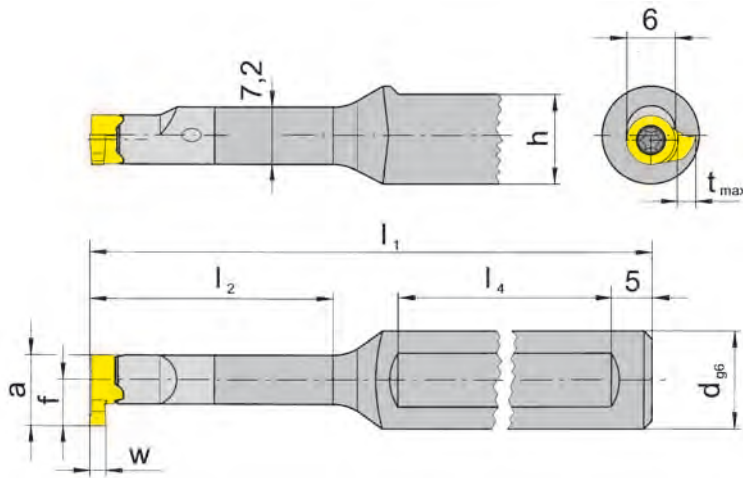

R = right hand version shown

L = left hand version

Part number	d	l ₁	l ₂	h	l ₄
R/LB10P.0012.00	12	70	12.5	11	40
R/LB10P.0012.01		80	21.0		45
R/LB10P.0012.02		90	30.0		45

State R or L version

w, a, t_{max} and f see inserts

Dimensions in mm

Further sizes upon request

Ordering note:

Toolholders with damaged seating can be repaired by HORN.

Spare parts

Toolholder	Screw	TORX PLUS® Wrench
R/LB10P.0012.0...	2.6.5T8EP	T8PL

TOOLHOLDER Type

B10P

with through coolant supply

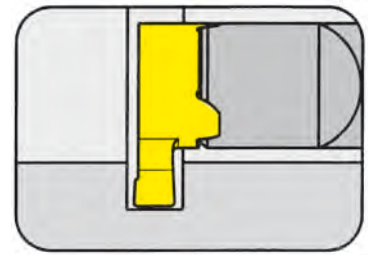

Bore Ø from	.354" (9.0 mm)
Depth of groove up to	.118" (3.0 mm)
Width of groove up to	.118" (3.0 mm)

Material of shank: Carbide - Giving a good vibration resistance

for use with Insert

Type 10P
S10P

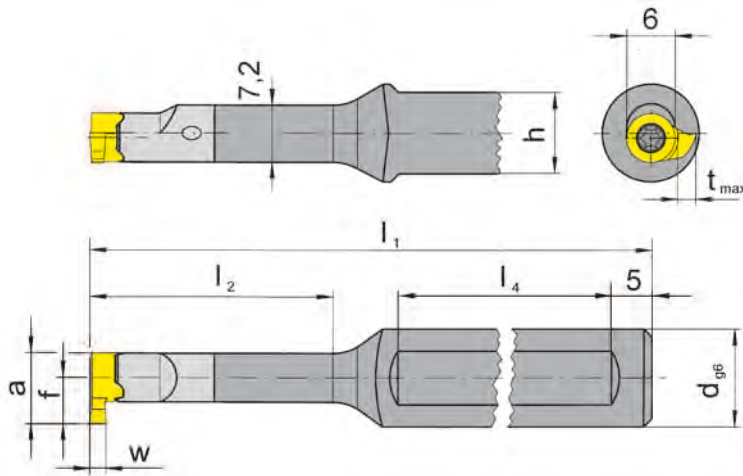

R = right hand version shown

L = left hand version

with 2 clamping flats

Part number	d	l ₁	l ₂	h	l ₄
R/LB10P.0012.2.00		70	12.5		40
R/LB10P.0012.2.01	12	80	21.0	11	45
R/LB10P.0012.2.02		90	30.0		45

State R or L version

w, a, t_{max} and f see inserts

Dimensions in mm

Further sizes upon request

Ordering note:

Toolholders with damaged seating can be repaired by HORN.

Spare parts

Toolholder	Screw	TORX PLUS® Wrench
R/LB10P.0012.2.0...	2.6.5T8EP	T8PL

TOOLHOLDER Type

B10P

with through coolant supply

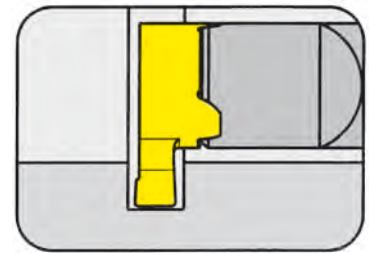

Bore Ø from	.354" (9.0 mm)
Depth of groove up to	.118" (3.0 mm)
Width of groove up to	.118" (3.0 mm)

Material of shank: Carbide - Giving a good vibration resistance

for use with Insert

Type 10P
S10P

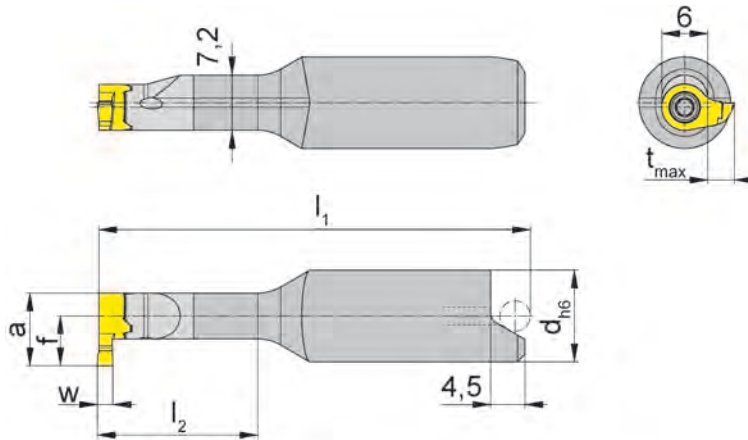

R = right hand version shown

L = left hand version

for shrinkage location
S = orientation

Part number	d	l ₁	l ₂
R/LB10P.0012.00S	12	48.7	12.5
R/LB10P.0012.01S		56.7	21.0
R/LB10P.0012.02S		65.7	30.0

State R or L version

w, a, t_{max} and f see inserts

Dimensions in mm

Further sizes upon request

Ordering note:

Toolholders with damaged seating can be repaired by HORN.



Example of assembly System „W&F“

Spare parts

Toolholder	Screw	TORX PLUS® Wrench
R/LB10P.0012.0...	2.6.5T8EP	T8PL

GROOVING (internal) $\geq \text{Ø} .354''$



INSERT Type

10P

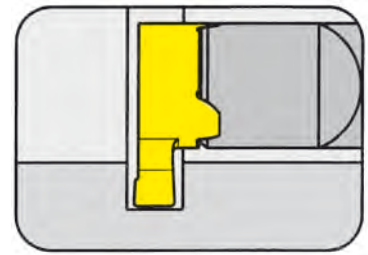

Bore Ø from	.354"
Depth of groove up to	.079"
Width of groove	.039 - .118"

for use with Toolholder

Type B10P
BU10P

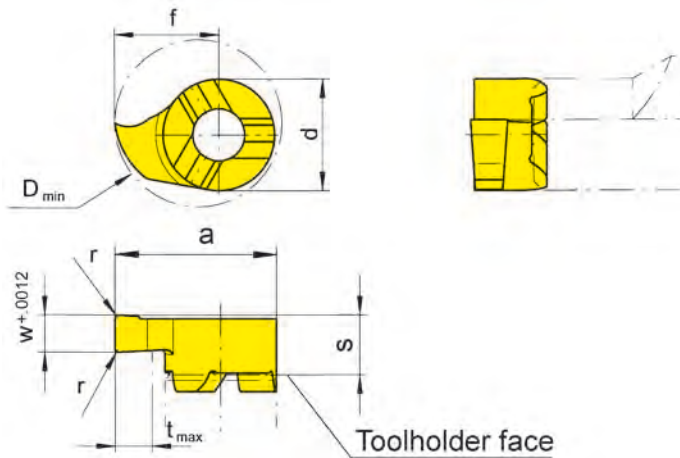

R = right hand version shown

L = left hand version

Part number	w	r	s	f	a	d	t _{max}	D _{min}	Carbide grades			
									MG12	TN35	TI25	TH35
R/L10P.0100.1.00	.039	-										▲▲
R/L10P.0150.1.00	.059	-										▲▲
R/L10P.0200.1.02	.079	.008	.142	.217	.335	.236	.079	.354				▲▲
R/L10P.0250.1.02	.098	.008										▲▲
R/L10P.0300.1.02	.118	.008										▲▲
									P			•
									M			•
									K			•
									S			•
									N			•
									H			

- ▲ on stock Δ 4 weeks
- main recommendation
- o alternative recommendation
- uncoated grades
- coated grades
- brazed/Cermet

Dimensions in inch

State R or L version

Carbide grades

GROOVING (internal) $\geq \text{Ø} .354''$



INSERT Type

S10P

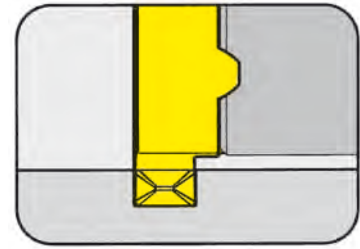

for use with Toolholder

Type B10P
BU10P

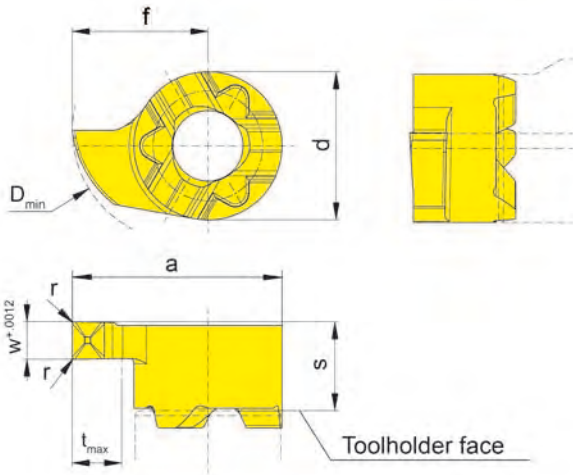

R = right hand version shown

L = left hand version

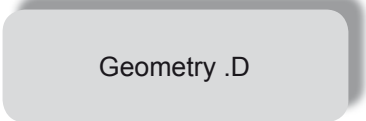

Part number	w	r	s	f	a	d	t _{max}	D _{min}	Carbide grades			
									MG12	TN35	TI25	TH35
R/LS10P.0100.1.D1	.039	.004										▲▲
R/LS10P.0150.1.D1	.059	.004	.142	.217	.335	.236	.079	.354				▲▲
R/LS10P.0200.1.D2	.079	.008										▲▲
									P			•
									M			•
									K			•
									S			•
									N			•
									H			•

- ▲ on stock Δ 4 weeks
- main recommendation
- o alternative recommendation
- uncoated grades
- coated grades
- brazed/Cermet

Dimensions in inch

State R or L version

Carbide grades

GROOVING (internal) $\geq \text{Ø} .394''$



INSERT Type

10P

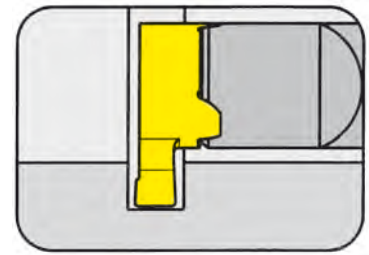

for use with Toolholder

Type B10P
BU10P

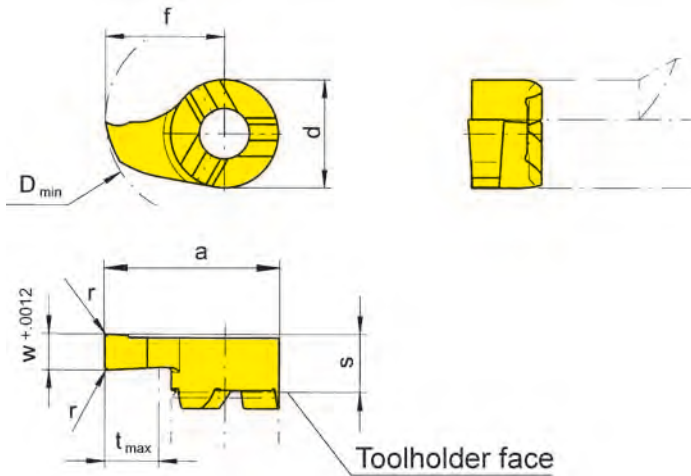

R = right hand version shown

L = left hand version

Part number	w	r	s	f	a	d	t _{max}	D _{min}	Carbide grades			
									MG12	TN35	TI25	TH35
R/L10P.0100.2.00	.039	-										▲▲
R/L10P.0150.2.00	.059	-	.142	.256	.374	.236	.118	.394				▲▲
R/L10P.0200.2.02	.079	.008										▲▲
									P			•
									M			•
									K			•
									S			•
									N			•
									H			

- ▲ on stock Δ 4 weeks
- main recommendation
- o alternative recommendation
- uncoated grades
- coated grades
- brazed/Cermet

Dimensions in inch

State R or L version

Carbide grades

GROOVING (internal) $\geq \text{Ø} .394''$



INSERT Type

S10P

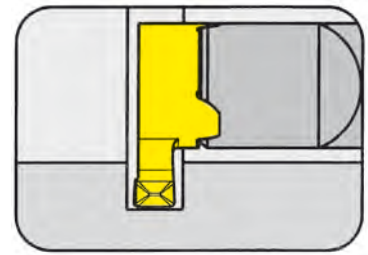

Bore Ø from	.394"
Depth of groove up to	.118"
Width of groove	.059 - .079"

for use with Toolholder

Type B10P
BU10P

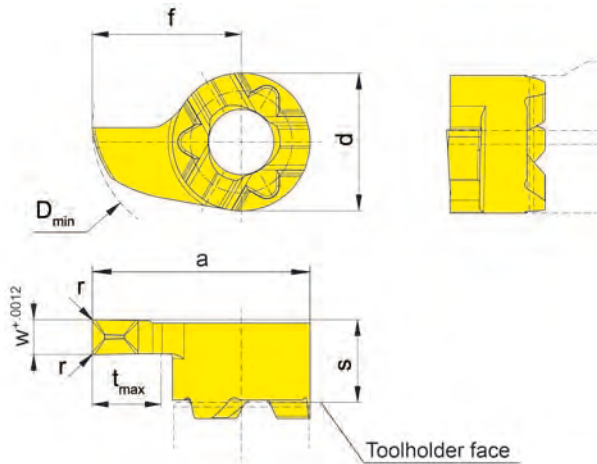

R = right hand version shown

L = left hand version

Geometry .D

Part number	w	r	s	f	a	d	t _{max}	D _{min}	Carbide grades			
									MG12	TN35	TI25	TH35
R/LS10P.0150.2.D1	.059	.004	.142	.256	.374	.236	.118	.394				▲▲
R/LS10P.0200.2.D2	.079	.008	.142	.256	.374	.236	.118	.394				▲▲
									P			•
									M			•
									K			•
									S			•
									N			•
									H			•

▲ on stock Δ 4 weeks
• main recommendation
o alternative recommendation
■ uncoated grades
■ coated grades
■ brazed/Cermet

Dimensions in inch

State R or L version

Carbide grades

D

INSERT Type

S10P

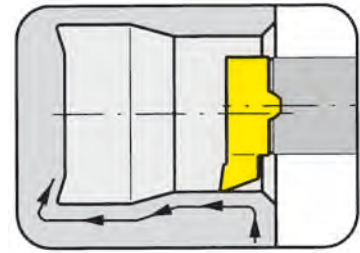

Bore Ø from $.346''$
 Depth of undercut up to $.075''$

for use with Toolholder

Type B10P
 BU10P

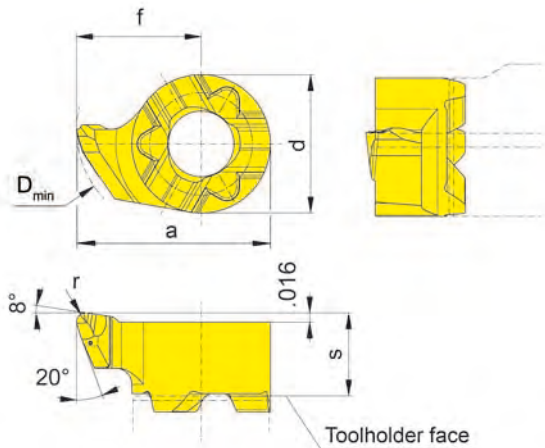

R = right hand version shown

L = left hand version

Geometry .R

Part number	r	s	f	a	d	D _{min}	Carbide grades			
							MG12	TN35	TI25	TH35
LS10P.1854.R2	.008									▲
RS10P.1854.R2	.008					.346				▲
LS10P.1854.R4	.016	.142	.213	.331	.236					▲
RS10P.1854.R4	.016									▲
							P			•
							M			•
							K			•
							S			•
							N			•
							H			•

- ▲ on stock Δ 4 weeks
- main recommendation
- o alternative recommendation
- uncoated grades
- coated grades
- brazed/Cermet

Dimensions in inch

State R or L version

The modified geometry allows boring of bores $\geq \text{Ø} .346''$ and profiling of reliefs as per DIN 509 form E and F.

PCD- or CBN-tipped inserts upon request.

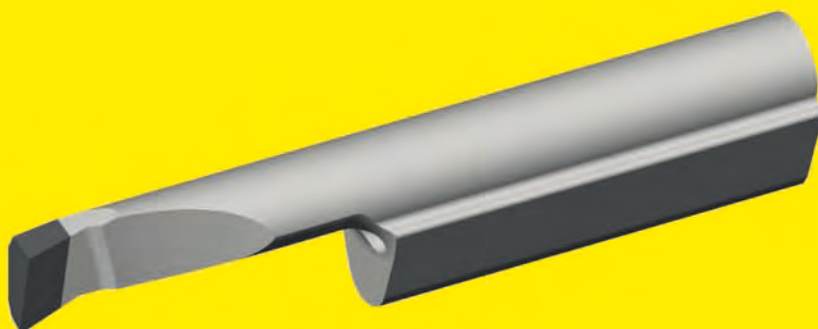

Supermini®
Turning of hardened parts
from bore $\varnothing > .118"$

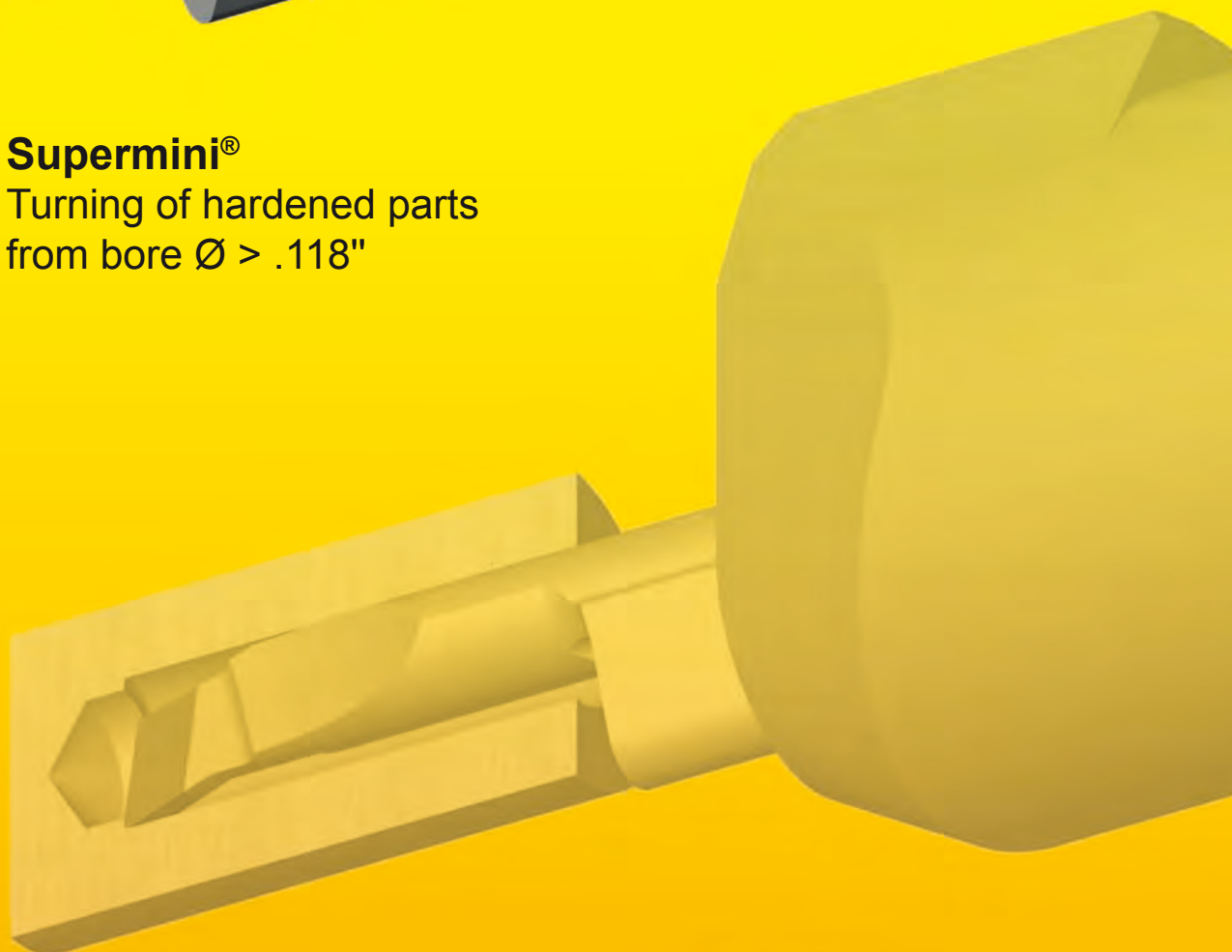

D



MINI
PCD-tipped insert



D11

HCG - HORN Catalog Guide

Bore Ø	Product line								
	105	110	108	10P	111	11P	114	116	18P
≥ .008" (0.2 mm)	•								
≥ .236" (6.0 mm)	•	•							
≥ .268" (6.8 mm)	•	•							
≥ .307" (7.8 mm)		•	•						
≥ .315" (8.0 mm)		•	•						
≥ .346" (8.8 mm)				•					
≥ .354" (9.0 mm)		•	•	•					
≥ .386" (9.8 mm)					•	•			
≥ .394" (10.0 mm)		•		•	•				
≥ .419" (10.5 mm)						•			
≥ .433" (11.0 mm)					•	•			
≥ .492" (12.5 mm)							•		
≥ .551" (14.0 mm)							•	•	
≥ .630" (16.0 mm)								•	
≥ .650" (16.5 mm)							•		
≥ .689" (17.5 mm)									•

Groove depth ≤ (inch)	.098"	.157"	.039"	.118"	.091"	.138"	.256"	.169"	.315"
Groove depth ≤ (mm)	2.5	4.0	1.0	3.0	2.3	3.5	6.5	4.3	8.0
Width of groove inch	.020"-.079"	.039"-.250"	.029"-.079"	.039"-.118"	.029"-.125"	.039"-.118"	.029"-.125"	.029"-.157"	.071"-.118"
Width of groove mm	0.5 - 2.0	1.0 - 6.35	0.74 - 2.0	1.0 - 3.0	0.74 - 3.18	1.0 - 3.0	0.74 - 3.18	0.74 - 4.0	1.8 - 3.0

Application	Product line								
	105	110	108	10P	111	11P	114	116	18P
Grooving	•	•	•	•	•	•	•	•	•
Boring	•	•	•	•	•	•	•	•	•
Threading	•		•		•		•	•	
Chamfering	•		•		•		•	•	
Face Grooving	•	•					•		
Hard turning	•		•		•		•	•	

Chapter	A	B	C	D	E	F	G	H	J
---------	----------	----------	----------	----------	----------	----------	----------	----------	----------

Special tools upon request

MINI CARBIDE GROOVING TOOLS

Toolholder
BU111 / B111

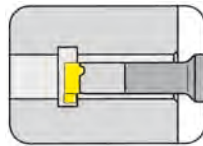

Page E2-E6

Toolholder
R/L125

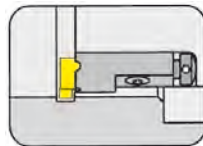

Page E7

Inserts
U111 / 111 / S111
≥ Ø .433" (11.0 mm)



Page E8-E9

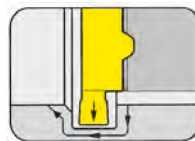

Page E10-E11



Page E12-E14

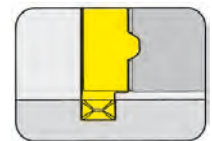

Page E15



Page E16-E17

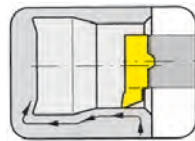

Page E18-E20

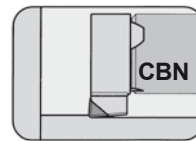

Page E21



Page E23

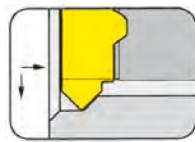

Page E24

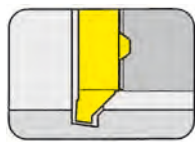

Page E25

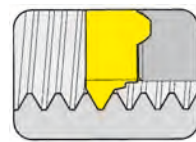

Page E26-E27

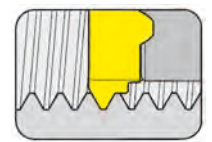

Page E28-E29

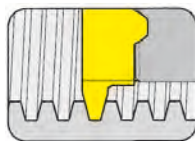

Page E30-E31

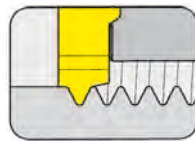

Page E32

E

Technical Instructions Page L1 - L9

TOOLHOLDER Type

BU111

with through coolant supply

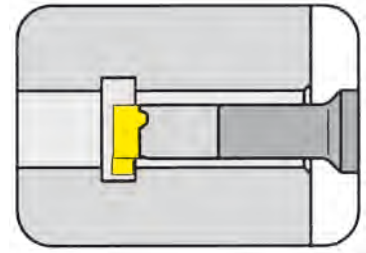

Bore Ø from	.433"
Depth of groove up to	.091"
Width of groove up to	.125"

Material of shank: Carbide - Giving a good vibration resistance

for use with Insert

Type 111
S111
U111

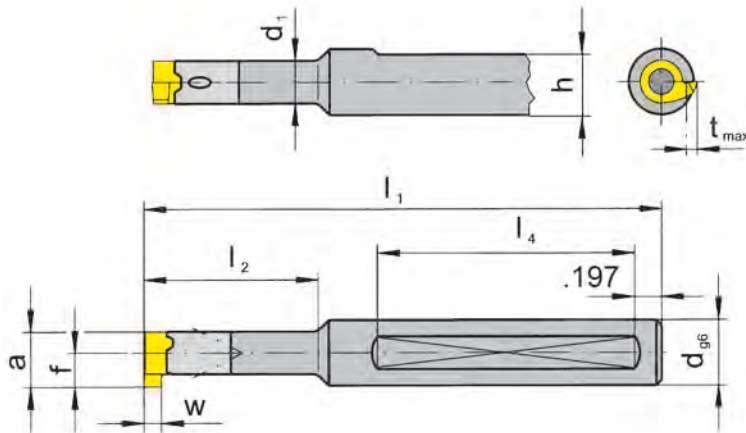

Picture = right hand cutting version shown

Part number	d	l ₁	l ₂	h	l ₄	d ₁	Remark
BU111.ST05.00	.500	2.953	.650	.460	1.570	.315	* Steel toolholder
BU111.0500.01		3.740	1.142				
BU111.0500.02	.500	4.331	1.654	.460	1.970	.315	
BU111.0500.03		4.724	2.205				

Further sizes upon request

w, a, t_{max} and f see inserts

Dimensions in inch

Note:

Toolholders can be used in right and left hand inserts.
Toolholders with damaged seating can be repaired by HORN.

* Steel toolholder is not repairable.

Spare parts

Toolholder	Screw	TORX PLUS® Wrench
BU111....	3.5.12T10EP	T10PL

TOOLHOLDER Type

B111

with through coolant supply

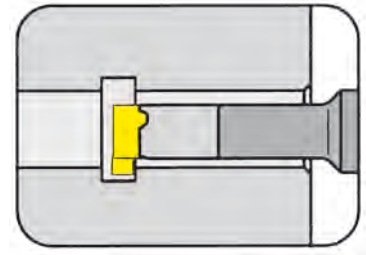

Bore Ø from	.433" (11.0 mm)
Depth of groove up to	.091" (2.3 mm)
Width of groove up to	.125" (3.18 mm)

Material of shank: Carbide - Giving a good vibration resistance

for use with Insert

Type 111
S111
U111

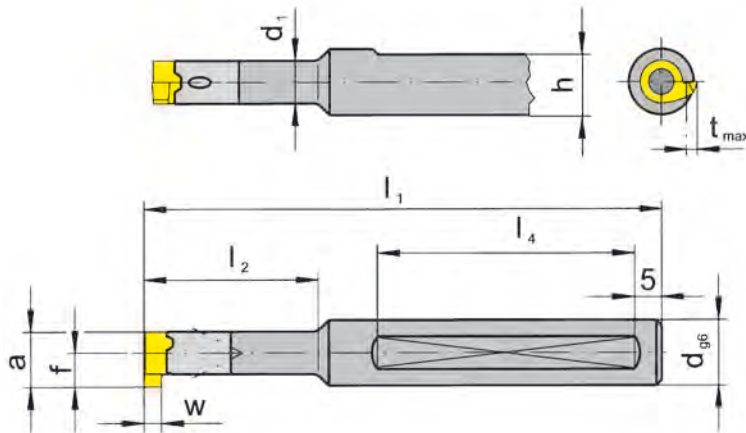

Picture = right hand cutting version shown

Part number	d	l ₁	l ₂	h	l ₄	d ₁
B111.0012.00		75	16.5		40	
B111.0012.01	12	95	29.0	11	50	8
B111.0012.02		110	42.0		50	
B111.0012.03		120	56.0		50	

Further sizes upon request

w, a, t_{max} and f see inserts

Dimensions in mm

Ordering note:

Toolholders can be used in right and left hand inserts.
Toolholders with damaged seating can be repaired by HORN.

Spare parts

Toolholder	Screw	TORX PLUS® Wrench
B111.0012.0...	3.5.12T10EP	T10PL



TOOLHOLDER Type

B111

with through coolant supply

Bore Ø from	.433" (11.0 mm)
Depth of groove up to	.091" (2.3 mm)
Width of groove up to	.125" (3.18 mm)

Material of shank: Carbide - Giving a good vibration resistance

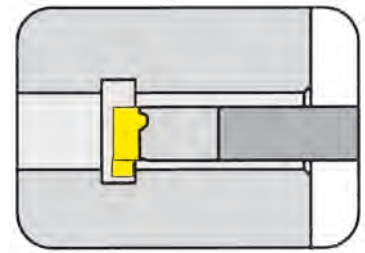

for use with Insert

Type 111
S111
U111

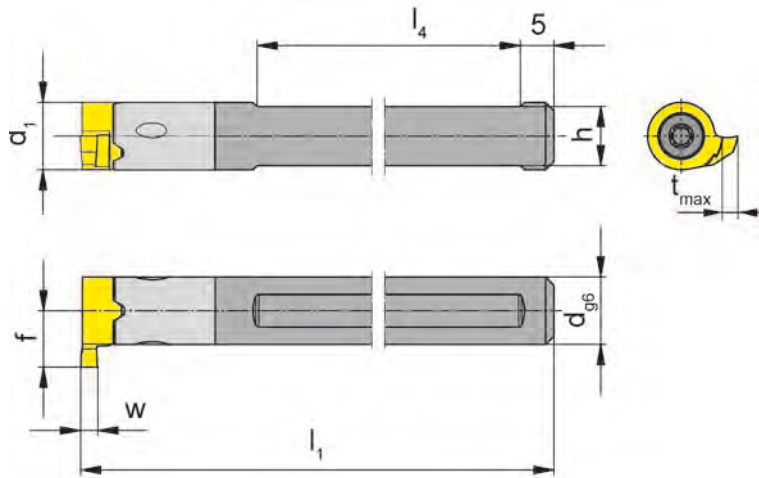

Picture = right hand cutting version shown

Part number	d	l ₁	h	l ₄	d ₁
B111.0008.01	8	80	7	55	8
B111.0008.01A	8	80	-	-	-

Further sizes upon request

w, a, t_{max} and f see inserts

Dimensions in mm

Ordering note:

Toolholders can be used in right and left hand inserts.
Toolholders with damaged seating can be repaired by HORN.

Spare parts

Toolholder	Screw	TORX PLUS® Wrench
B111.0008.01	3.5.12T10EP	T10PL

TOOLHOLDER Type

B111

with through coolant supply

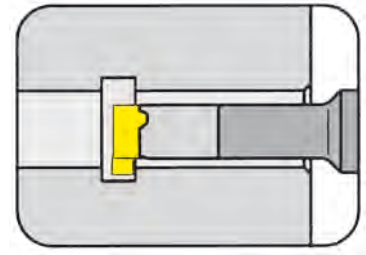

Bore Ø from	.433" (11.0 mm)
Depth of groove up to	.091" (2.3 mm)
Width of groove up to	.125" (3.18 mm)

Material of shank: Carbide - Giving a good vibration resistance

for use with Insert

Type 111
S111
U111

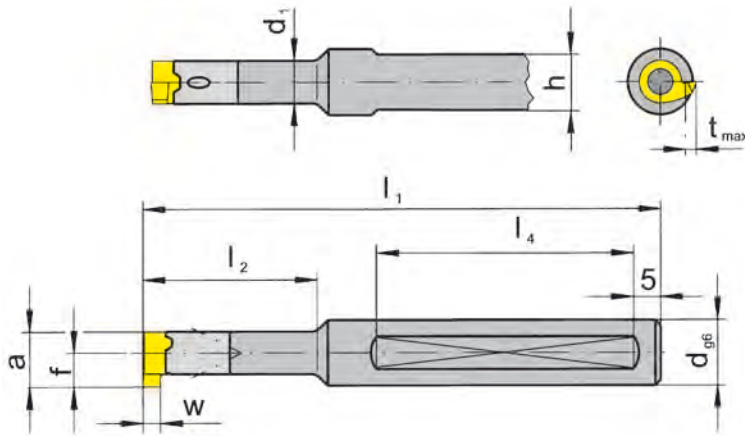

Picture = right hand cutting version shown

with 2 clamping flats

Part number	d	l ₁	l ₂	h	l ₄	d ₁
B111.0012.2.00	12	75	16.5	11	40	8
B111.0012.2.01		95	29.0		50	
B111.0012.2.02		110	42.0		50	
B111.0012.2.03		120	56.0		50	

Further sizes upon request

w, a, t_{max} and f see inserts

Dimensions in mm

Ordering note:

Toolholders can be used in right and left hand inserts.
Toolholders with damaged seating can be repaired by HORN.

Spare parts

Toolholder	Screw	TORX PLUS® Wrench
B111.0012.2.0...	3.5.12T10EP	T10PL



TOOLHOLDER Type

B111

with through coolant supply

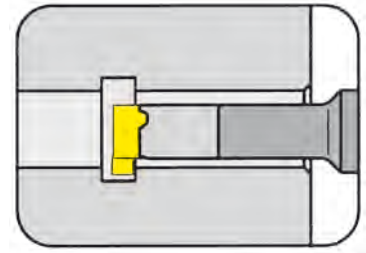

Bore Ø from	.433" (11.0 mm)
Depth of groove up to	.091" (2.3 mm)
Width of groove up to	.125" (3.18 mm)

Material of shank: Carbide - Giving a good vibration resistance

for use with Insert

Type 111
S111
U111

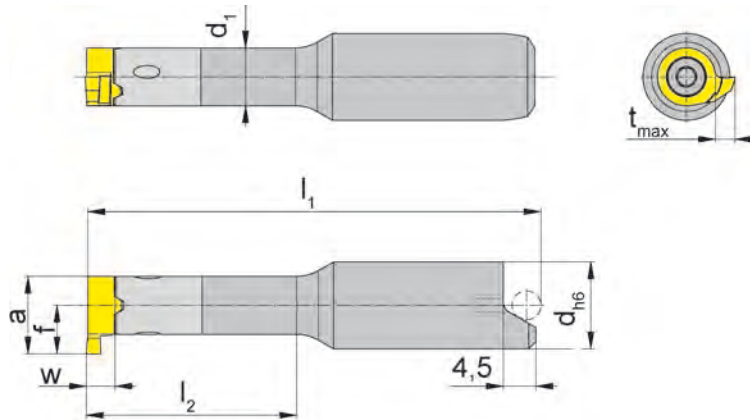

Picture = right hand cutting version shown

for shrinkage location
S = orientation

Part number	d	l ₁	l ₂	d ₁
B111.0012.00S	12	50.7	16.5	8
B111.0012.01S		62.7	29.0	
B111.0012.02S		75.7	42.0	
B111.0012.03S		89.7	56.0	

Further sizes upon request

w, a, t_{max} and f see inserts

Dimensions in mm

Ordering note:

Toolholders can be used in right and left hand inserts.
Toolholders with damaged seating can be repaired by HORN.



Example of assembly System „W&F“

Spare parts

Toolholder	Screw	TORX PLUS® Wrench
B111.0012.0...	3.5.12T10EP	T10PL

CARTRIDGE Type

125

for customized tools

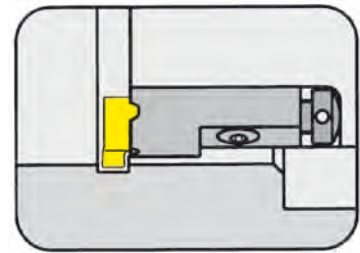

Bore Ø from	.787" (20.0 mm)
Depth of groove up to	.091" (2.3 mm)
Width of groove up to	.125" (3.18 mm)

for use with Insert

Type 111
S111
U111

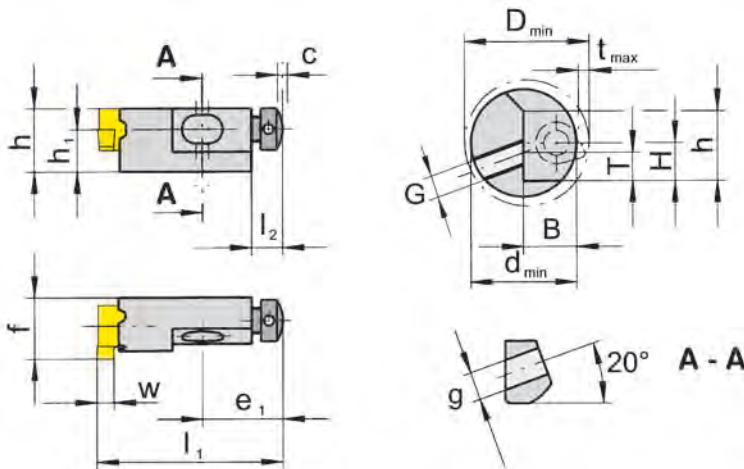

R = right hand version shown

L = left hand version

Part number	h_1	f	h	l_1	D_{min}	e_1	l_2	c	g	Clamping range
R/L125.0608.00	6	11.2	10	30	20	12.8	5	2	4.5	0.5 - 3.0

State R or L version

w and t_{max} see inserts

Dimensions in mm

Height of cutting edge h_1

Special height $h_1 = 5$ mm available upon request

Seating sizes	H	T	B	G	d_{min}
R/L125.0608.00	6	4.5	8.5	M4	16

Spare parts

Cartridge	Screw	Screw	Adjust screw axial	TORX PLUS® Wrench
R/L125.0608.00	4.12.125	3.5.12T10EP	4.06.020	T10PL



GROOVING (internal) $\geq \text{Ø} .433''$



INSERT Type

U111

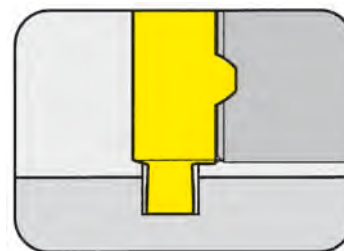

Bore Ø from	.433"
Depth of groove up to	.047"
Width of groove	.031 - .039"

for use with Toolholder

Type 125
B111
BU111

E

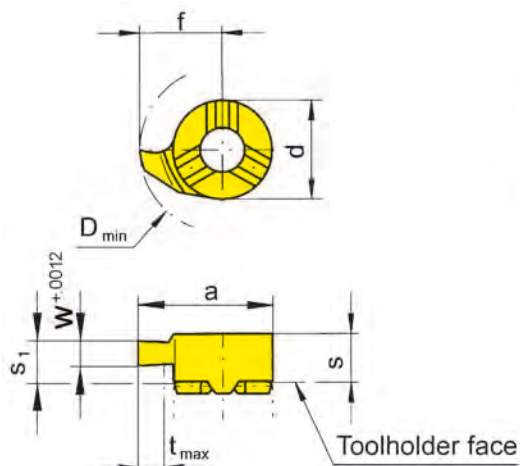

R = right hand version

L = left hand version

not face cutting,
limited depth of cut

Part number	w	s ₁	s	f	a	d	t _{max}	D _{min}	Carbide grades					
									MG12	TN35	TI25	TF45	TH35	
R/LU111.0031.00	.031							.433	▲/▲	▲/▲				
R/LU111.0039.00	.039	.156	.163	.264	.421	.315	.047	.433	▲/▲	▲/▲				
▲ on stock Δ 4 weeks ● main recommendation ○ alternative recommendation □ uncoated grades ■ coated grades ■ brazed/Cermet										P	○	●		
										M	●	●		
										K	●	●		
										S	●	●		
										N	●	●		
										H				

Dimensions in inch

State R or L version

GROOVING (internal) $\geq \varnothing .433''$



INSERT Type

111

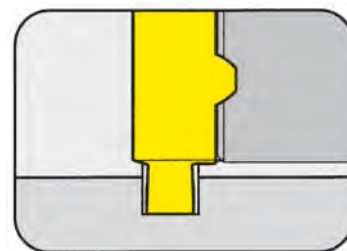

Bore \varnothing from	.433"
Depth of groove up to	.059"
Width of circlip Nw	.028 - .035"

Widths for circlip grooves DIN 471/472

for use with Toolholder

Type 125
B111
BU111

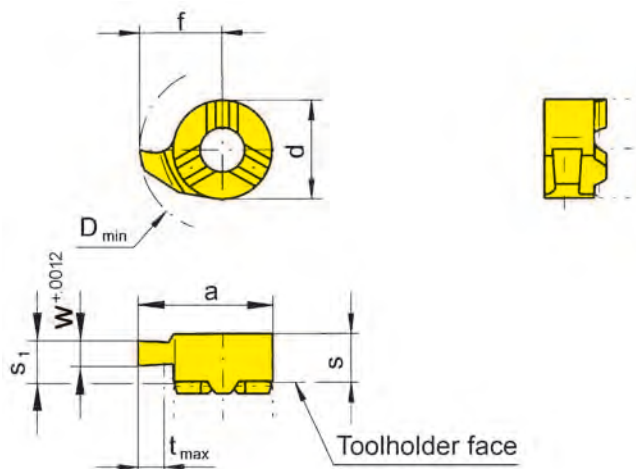

R = right hand version shown

L = left hand version

not face cutting,
limited depth of cut

Part number	Nw	w	s ₁	s	f	a	d	t _{max}	D _{min}	Carbide grades				
										MG12	TN35	TI25	TF45	TH35
R/L111.0070.00	.028	.029						.047	.433		▲/▲			▲/▲
R/L111.0080.00	.031	.033	.156	.163	.264	.421	.315	.051	.433		▲/▲			▲/
R/L111.0090.00	.035	.037						.059	.433		▲/▲			▲/▲
▲ on stock Δ 4 weeks ● main recommendation ○ alternative recommendation □ uncoated grades ■ coated grades ■ brazed/Cermet										P	○	●	■	■
										M	●	●	■	■
										K	●	●	■	■
										S	●	●	■	■
										N	●	●	■	■
										H	■	■	■	■

Dimensions in inch

State R or L version

Carbide grades



NC-PROFILING (internal) $\geq \text{Ø} .433''$



INSERT Type

U111

Bore Ø from	.433"
Depth of groove up to	.091"
Width of groove	.031 - .125

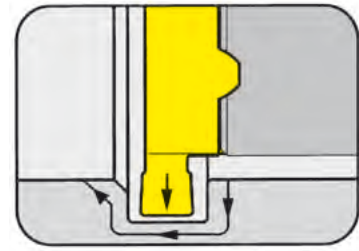

for use with Toolholder

Type 125
B111
BU111

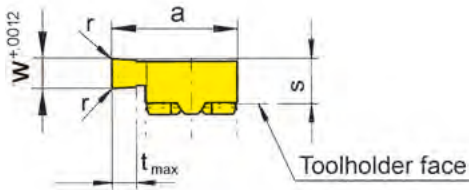
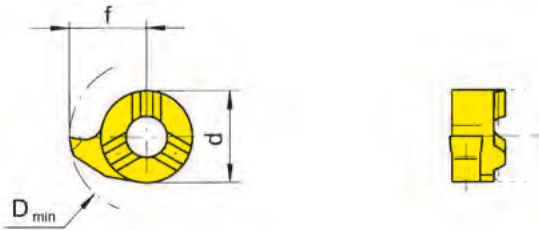

R = right hand version shown

L = left hand version

with corner radius

Part number	w	r	s	f	a	d	t _{max}	D _{min}	MG12	TN35	T125	TF45	TH35
R/LU111.0031.08	.031									▲/▲			
R/LU111.0046.08	.046									▲/▲			
R/LU111.0062.08	.062	.008	.156	.264	.421	.315	.091	.433	Δ	▲/▲		▲/	
R/LU111.0078.08	.078									▲/▲		Δ/	
R/LU111.0094.08	.094									▲/▲		Δ/	
R/LU111.0125.08	.125									▲/			
R/LU111.0046.16	.046									▲/			
R/LU111.0062.16	.062									▲/▲			
R/LU111.0078.16	.078	.016	.156	.264	.421	.315	.091	.433		▲/			
R/LU111.0094.16	.094									▲/▲			
R/LU111.0125.16	.125									Δ/			

- ▲ on stock Δ 4 weeks
- main recommendation
- alternative recommendation
- uncoated grades
- coated grades
- brazed/Cermet

Dimensions in inch

State R or L version

	P	M	K	S	N	H
MG12	○	●	●	●	●	●
TN35	●	●	●	●	●	●
T125	●	●	●	●	●	●
TF45	●	●	●	●	●	●
TH35	●	●	●	●	●	●

Carbide grades

NC-PROFILING (internal) $\geq \varnothing .433''$



INSERT Type

111

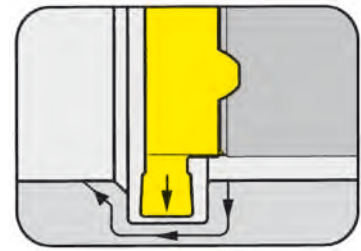

Bore \varnothing from	.433"
Depth of groove up to	.091"
Width of groove	.079"

for use with Toolholder

Type 125
B111
BU111

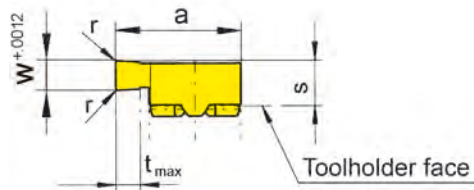
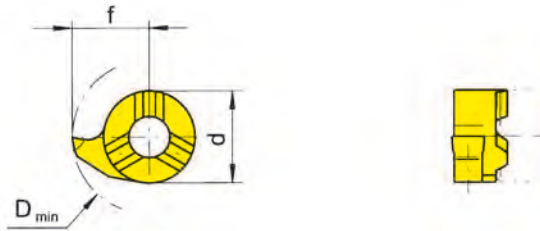

R = right hand version shown

L = left hand version

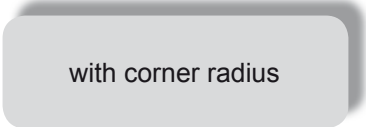

Part number	w	r	s	f	a	d	t _{max}	D _{min}	Carbide grades				
									MG12	TN35	TI25	TF45	TH35
R/L111.0200.02	.079	.008	.156	.264	.421	.315	.091	.433	▲/▲	▲/▲	▲/▲		▲/▲
									P	o	•	•	•
									M	•	•	•	•
									K	•	•	•	•
									S	•	•	•	•
									N	•	•	•	•
									H				

- ▲ on stock Δ 4 weeks
- main recommendation
- o alternative recommendation
- uncoated grades
- coated grades
- brazed/Cermet

Dimensions in inch

State R or L version

Carbide grades

GROOVING (internal) $\geq \text{Ø} .433''$



INSERT Type

U111

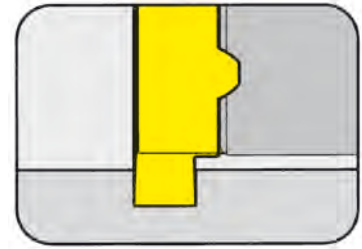

Bore Ø from	.433"
Depth of groove up to	.091"
Width of groove	.046 - .078"

for use with Toolholder

Type 125
B111
BU111

E

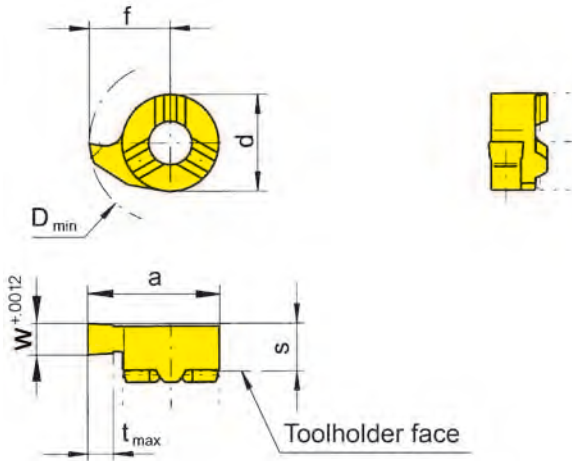

R = right hand version shown

L = left hand version

Part number	w	s	f	a	d	t _{max}	D _{min}	Carbide grades				
								MG12	TN35	TI25	TF45	TH35
R/LU111.0046.00	.046							▲/	▲/▲	Δ/		
R/LU111.0056.00	.056							▲/	▲/▲			
R/LU111.0062.00	.062	.156	.264	.421	.315	.091	.433	▲/	▲/▲	Δ/	▲/	
R/LU111.0078.00	.078								▲/▲			
								P	o	•	•	•
								M	•	•	•	•
								K	•	•	•	•
								S	•	•	•	•
								N	•	•	•	•
								H				

- ▲ on stock Δ 4 weeks
- main recommendation
- o alternative recommendation
- uncoated grades
- coated grades
- brazed/Cermet

Dimensions in inch

State R or L version

Carbide grades

GROOVING (internal) $\geq \text{Ø} .433''$



INSERT Type

111

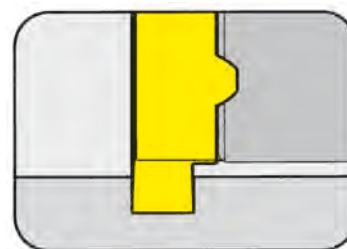

Bore Ø from	.433"
Depth of groove up to	.091"
Width of circlip Nw	.043 - .063"

Widths for circlip grooves DIN 471/472

for use with Toolholder

Type 125
B111
BU111

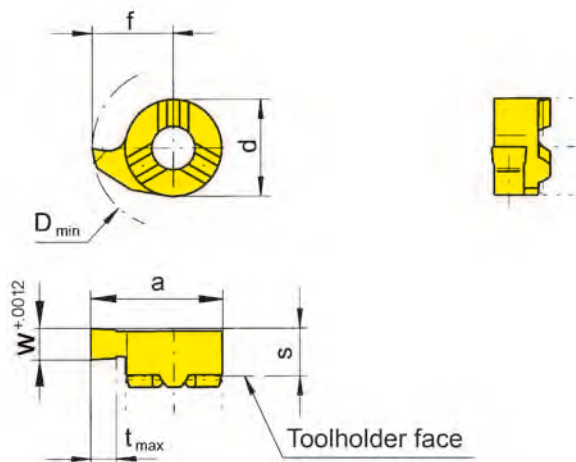

R = right hand version shown

L = left hand version

Part number	Nw	w	s	f	a	d	t _{max}	D _{min}	Carbide grades				
									MG12	TN35	TI25	TF45	TH35
R/L111.0110.00	.043	.047							▲/▲	▲/▲			▲/▲
R/L111.0130.00	.051	.055	.156	.264	.421	.315	.091	.433	▲/▲	▲/▲			▲/▲
R/L111.0160.00	.063	.067							▲/▲	▲/▲			▲/▲
									P	o	•		•
									M	•	•		•
									K	•	•		•
									S	•	•		•
									N	•	•		•
									H				

- ▲ on stock Δ 4 weeks
- main recommendation
- o alternative recommendation
- uncoated grades
- coated grades
- brazed/Cermet

Dimensions in inch

Carbide grades

State R or L version

GROOVING (internal) $\geq \text{Ø} .433''$



INSERT Type

111

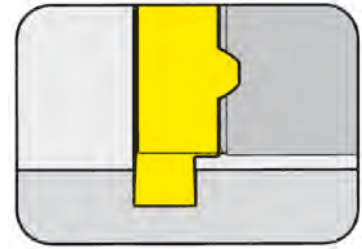

Bore Ø from	.433"
Depth of groove up to	.091"
Width of groove	.059 - .118"

for use with Toolholder

Type 125
B111
BU111

E

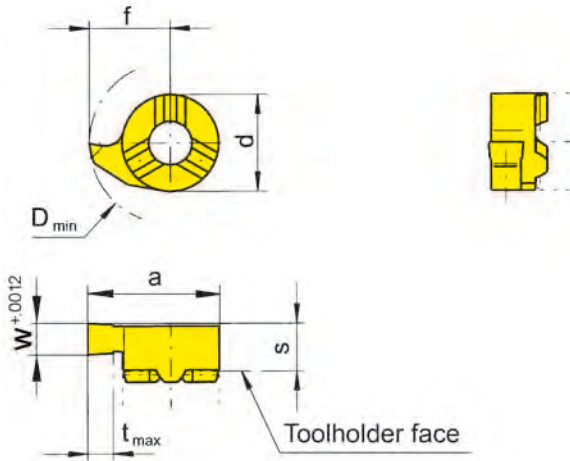

R = right hand version shown

L = left hand version

Part number	w	s	f	a	d	t _{max}	D _{min}	Carbide grades				
								MG12	TN35	TI25	TF45	TH35
R/L111.0150.00	.059							▲/▲	▲/▲			▲/▲
R/L111.0200.00	.079							▲/▲	▲/▲			▲/▲
R/L111.0250.00	.098	.156	.264	.421	.315	.091	.433	▲/▲	▲/▲			▲/▲
R/L111.0300.00	.118							▲/▲	▲/▲			▲/▲
								P	o	•		•
								M	•	•		•
								K	•	•		•
								S	•	•		•
								N	•	•		•
								H				

- ▲ on stock Δ 4 weeks
- main recommendation
- o alternative recommendation
- uncoated grades
- coated grades
- brazed/Cermet

Dimensions in inch

State R or L version

Carbide grades

GROOVING (internal) $\geq \text{Ø} .433''$



INSERT Type

S111

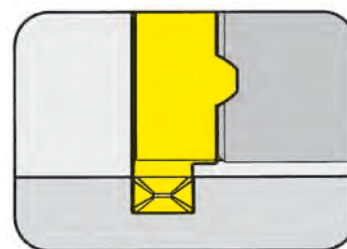

Bore Ø from	.433"
Depth of groove up to	.091"
Width of groove	.059 - .098"

for use with Toolholder

Type 125
B111
BU111

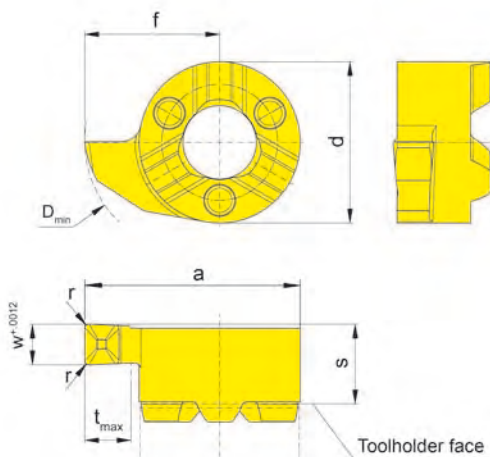

R = right hand version shown

L = left hand version

Geometry .D

Part number	w	r	s	f	a	d	t _{max}	D _{min}	Carbide grades				
									MG12	TN35	TI25	TF45	TH35
R/LS111.0150.D1	.059	.004											▲▲
R/LS111.0200.D2	.079	.008	.156	.264	.421	.315	.091	.433					▲▲
R/LS111.0250.D2	.098	.008											▲▲
									P				•
									M				•
									K				•
									S				•
									N				•
									H				•

- ▲ on stock Δ 4 weeks
- main recommendation
- o alternative recommendation
- uncoated grades
- coated grades
- brazed/Cermet

Dimensions in inch

State R or L version

Carbide grades



GROOVING (internal) $\geq \text{Ø} .433''$



INSERT Type

U111

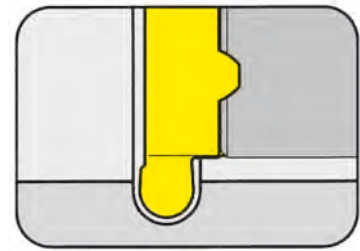

Bore Ø from	.433"
Depth of groove up to	.091"
Width of groove	.031 - .078"

for use with Toolholder

Type 125
B111
BU111

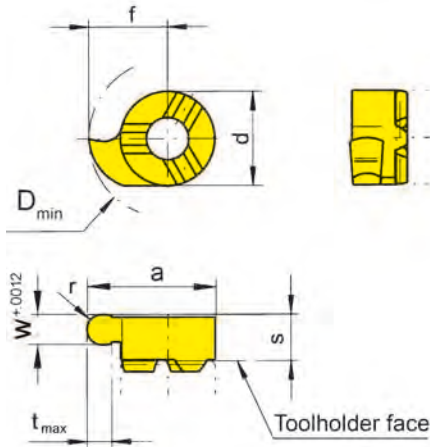

R = right hand version shown

L = left hand version

Full radius

Part number	w	r	s	f	a	d	t _{max}	D _{min}	Carbide grades				
									MG12	TN35	TI25	TF45	TH35
R/LU111.0015.31	.031	.015						.433	▲/▲	▲/▲			
R/LU111.0023.46	.046	.023							▲/▲	▲/▲			
R/LU111.0031.62	.062	.031	.156	.264	.421	.315	.091		▲/▲	▲/▲	Δ		
R/LU111.0039.78	.078	.039							▲/▲	▲/▲			
									P	o	•	•	•
									M	•	•	•	•
									K	•	•	•	•
									S	•	•	•	•
									N	•	•	•	•
									H				

- ▲ on stock Δ 4 weeks
- main recommendation
- o alternative recommendation
- uncoated grades
- coated grades
- brazed/Cermet

Dimensions in inch

State R or L version

Carbide grades

GROOVING (internal) $\geq \text{Ø} .433''$



INSERT Type

111

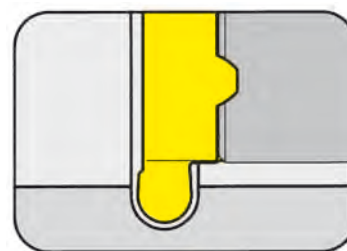

Bore Ø from	.433"
Depth of groove up to	.091"
Width of groove	.031 - .118"

for use with Toolholder

Type 125
B111
BU111

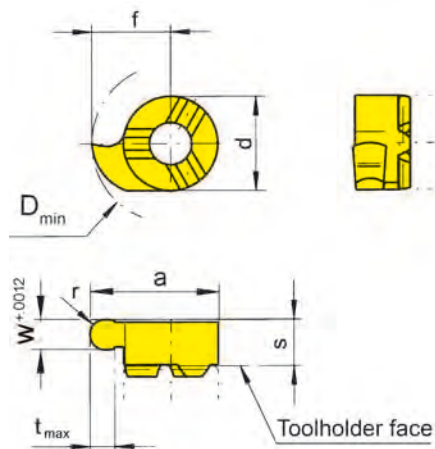

R = right hand version shown

L = left hand version

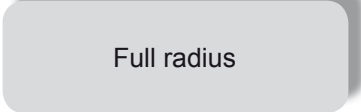

Part number	w	r	s	f	a	d	t _{max}	D _{min}	MG12	TN35	TI25	TF45	TH35
R/L111.0004.08	.031	.016								▲/▲			▲/▲
R/L111.0006.12	.047	.024							▲/▲	▲/▲			▲/▲
R/L111.0009.18	.071	.035	.156	.264	.421	.315	.091	.433	▲/▲	▲/▲			▲/▲
R/L111.0010.20	.079	.039							▲/▲	▲/▲			▲/▲
R/L111.0015.30	.118	.059							▲/▲	▲/▲			▲/▲
									P	o	•		•
									M	•	•		•
									K	•	•		•
									S	•	•		•
									N	•	•		•
									H				

- ▲ on stock Δ 4 weeks
- main recommendation
- o alternative recommendation
- uncoated grades
- coated grades
- brazed/Cermet

Dimensions in inch

State R or L version

Carbide grades

INSERT Type

111

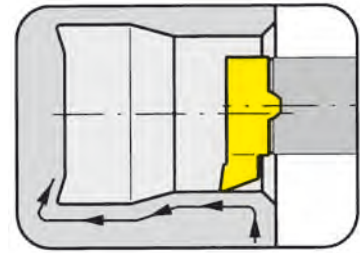

Bore Ø from $.386''$
 Depth of undercut up to $.091''$

for use with Toolholder

Type 125
 B111
 BU111

E

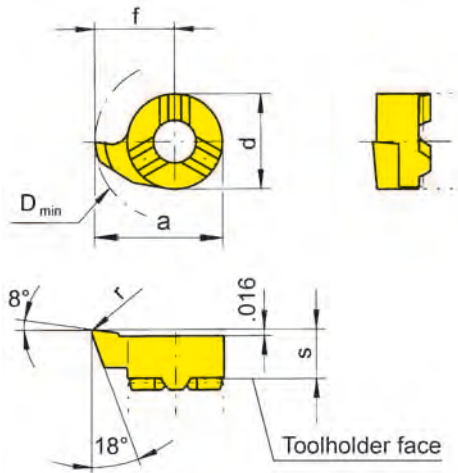

R = right hand version shown

L = left hand version

Part number	r	s	f	a	d	t _{max}	D _{min}	Carbide grades				
								MG12	TN35	TI25	TF45	TH35
R/L111.1855.02	.008	.156	.217	.374	.315	.051	.386	▲/▲	▲/▲	▲/▲		▲/▲
R/L111.1867.02	.008	.156	.264	.421	.315	.091	.433	▲/▲	▲/▲	▲/▲		▲/▲
▲ on stock Δ 4 weeks ● main recommendation ○ alternative recommendation □ uncoated grades ■ coated grades ■ brazed/Cermet								P	○	●	●	●
								M	●	●	●	●
								K	●	●	●	●
								S	●	●	●	●
								N	●	●	●	●
								H				

Dimensions in inch

State R or L version

The modified geometry allows boring of bores $\geq \text{Ø} .386''$ and profiling of reliefs as per DIN 509 form E and .

INSERT Type

S111

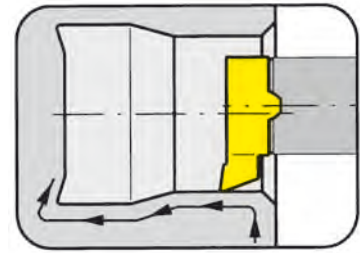

Bore Ø from .433"
 Depth of undercut up to .091"

for use with Toolholder

Type 125
 B111
 BU111

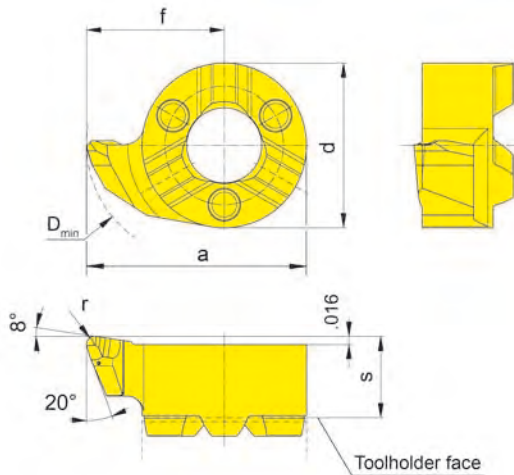

R = right hand version shown

L = left hand version

Geometry .R

Part number	r	s	f	a	d	D _{min}	Carbide grades				
							MG12	TN35	TI25	TF45	TH35
LS111.1867.R2	.008										▲
RS111.1867.R2	.008					.433					▲
LS111.1867.R4	.016	.156	.264	.421	.315						▲
RS111.1867.R4	.016										▲
							P				•
							M				•
							K				•
							S				•
							N				•
							H				•

- ▲ on stock Δ 4 weeks
- main recommendation
- o alternative recommendation
- uncoated grades
- coated grades
- brazed/Cermet

Dimensions in inch

State R or L version

The modified geometry allows boring of bores $\geq \text{Ø} .433''$ and profiling of reliefs as per DIN 509 form E and F.

INSERT Type

111

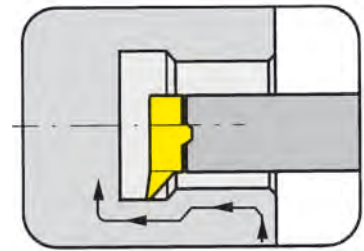

Bore Ø from $.433''$
 Depth of undercut up to $.091''$

for use with Toolholder

Type 125
 B111
 BU111

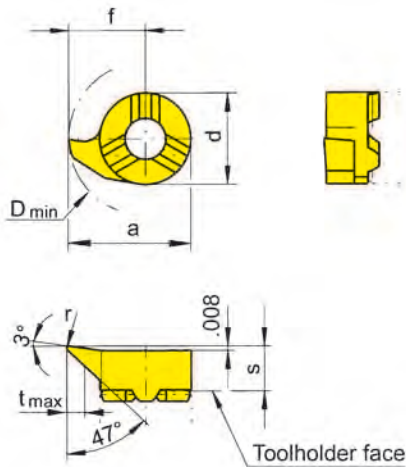

R = right hand version shown

L = left hand version

Part number	r	s	f	a	d	t _{max}	D _{min}	Carbide grades				
								MG12	TN35	TI25	TF45	TH35
R/L111.4767.02	.008	.156	.264	.421	.315	.091	.433		▲/▲	▲/▲		▲/▲
R/L111.4767.04	.016											▲/▲
								P	•	•	•	•
								M	•	•	•	•
								K	•	•	•	•
								S	•	•	•	•
								N	•	•	•	•
								H				

- ▲ on stock Δ 4 weeks
- main recommendation
- o alternative recommendation
- uncoated grades
- coated grades
- brazed/Cermet

Dimensions in inch

State R or L version

The modified geometry allows boring of bores $\geq \text{Ø} .433''$ and profiling of reliefs as per DIN 509 form

INSERT Type

111

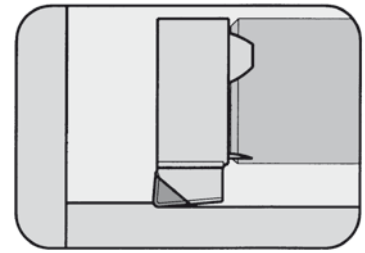

Bore Ø from .394"

for use with Toolholder

Type 125
B111
BU111

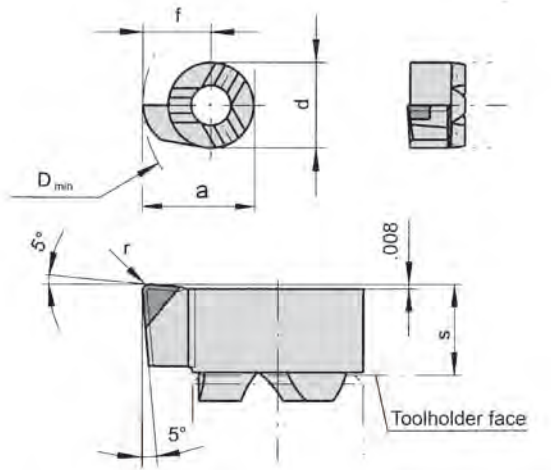

R = right hand version shown

CBN tipped

E

Part number	r	s	f	a	d	D _{min}		CB10
R111.0557.03.B	.012	.156	.224	.382	.315	.394	▲	
R111.0567.03.B	.012	.156	.264	.421	.315	.433	▲	

- ▲ on stock Δ 4 weeks
- main recommendation
- alternative recommendation
- uncoated grades
- coated grades
- brazed/Cermet

Dimensions in inch

P	
M	
K	
S	
N	
H	

Carbide grades

Thread milling (by circular interpolation)

- high cylindricity
- constant milled profil
- simple checking of thread
- in high strength material

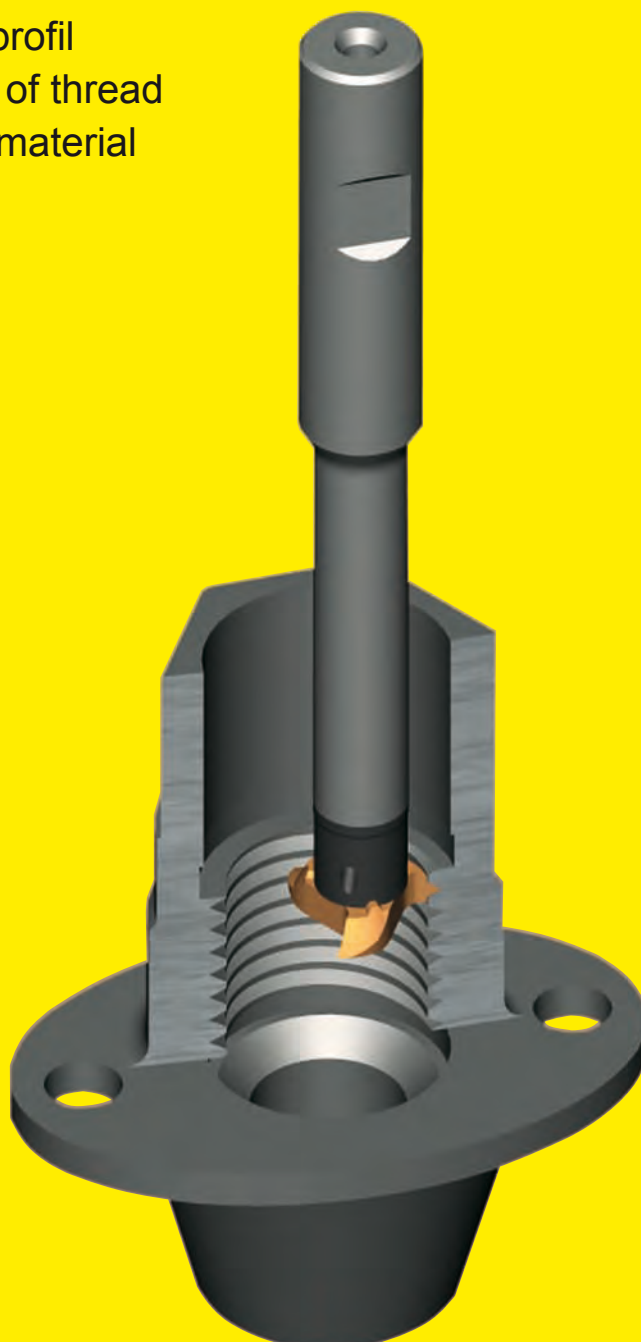

For further information please see HORN catalog "CARBIDE MILLING TOOLS".

BACKBORING (internal)



INSERT Type

111

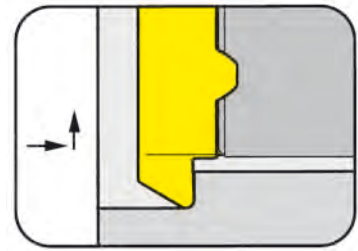

Bore Ø from .433"

for use with Toolholder

Type 125
B111
BU111

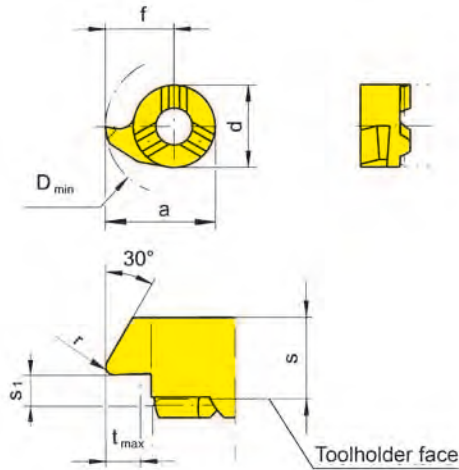

R = right hand version shown

L = left hand version

Part number	r	s ₁	s	f	a	d	t _{max}	D _{min}	MG12	TN35	TI25	TF45	TH35
R/L111.3067.02	.008	.055	.163	.264	.421	.315	.091	.433		▲/▲			▲/▲
R/L111.3067.04	.016	.055	.163	.264	.421	.315	.091	.433		/▲			▲/▲
									P	•	•	•	•
									M	•	•	•	•
									K	•	•	•	•
									S	•	•	•	•
									N	•	•	•	•
									H	•	•	•	•

- ▲ on stock Δ 4 weeks
- main recommendation
- o alternative recommendation
- uncoated grades
- coated grades
- brazed/Cermet

Dimensions in inch

State R or L version

Carbide grades

CHAMFERING and BACKBORING (internal)



INSERT Type

111

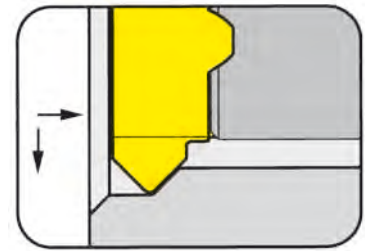

Bore Ø from .433"

for use with Toolholder

Type 125
B111
BU111

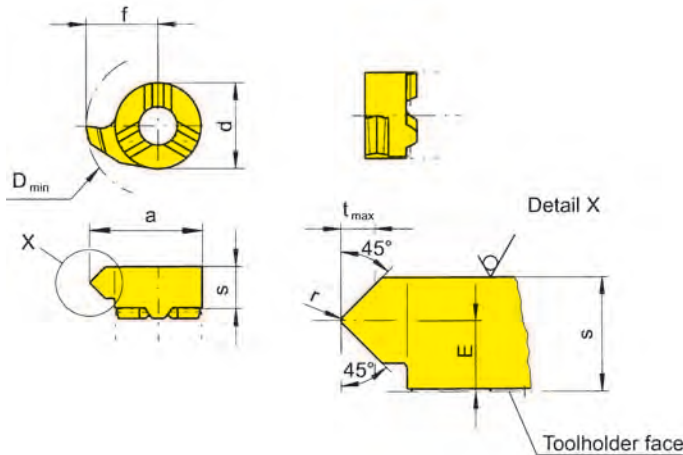

R = right hand version shown

L = left hand version

Part number	E	r	s	f	a	d	t _{max}	D _{min}	Carbide grades					
									MG12	TN35	TI25	TF45	TH35	
R/L111.4545.02	.094	.008	.163	.264	.421	.315	.059	.433		▲/▲				
▲ on stock Δ 4 weeks ● main recommendation ○ alternative recommendation □ uncoated grades ■ coated grades ■ brazed/Cermet										P	●			
										M	●			
										K	●			
										S	●			
										N	●			
										H				

Dimensions in inch

State R or L version

INSERT Type

111

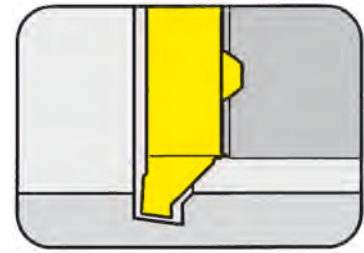

Bore Ø from .433"

for use with Toolholder

Type 125
B111
BU111

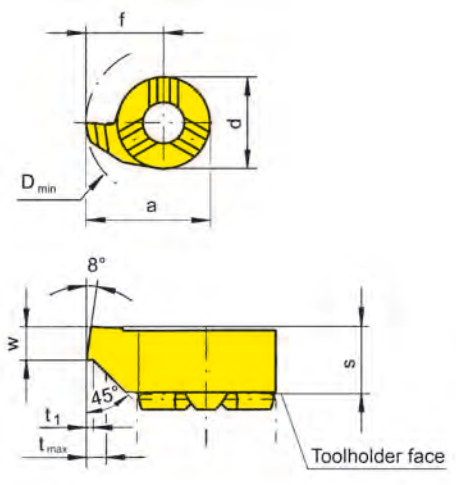

R = right hand version shown

L = left hand version

Part number	w	s	f	a	d	t ₁	t _{max}	D _{min}	Carbide grades					
									MG12	TN35	TI25	TF45	TH35	
R/L111.0810.45	.039	.156	.264	.421	.315	.008	.059	.433	▲/▲		▲/▲			
▲ on stock Δ 4 weeks														
● main recommendation														
○ alternative recommendation														
□ uncoated grades														
■ coated grades														
■ brazed/Cermet														

Dimensions in inch

State R or L version

Carbide grades

THREADING (internal) Partial profile



INSERT Type

111

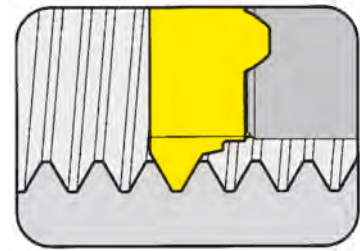

Bore Ø from Pitch .433" (11.0 mm)
2.0 - 2.5 mm

for use with Toolholder

Type 125
B111
BU111

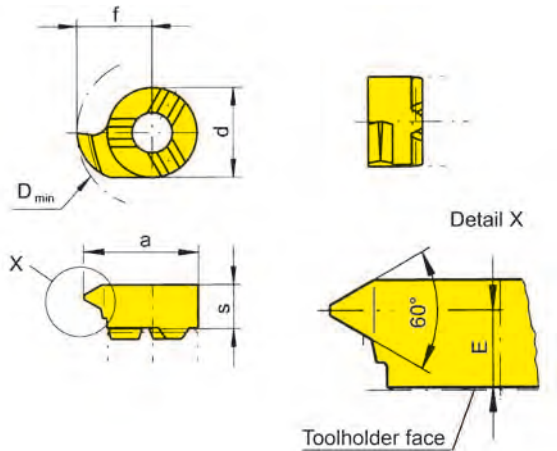

R = right hand version shown

L = left hand version

Metric ISO standard thread

Part number	P	E	s	f	a	d	D _{min}	Carbide grades					
								MG12	TN35	Ti25	TF45	TH35	
R/L111.1020.01	2.0	3.0	4.15	6.7	10.7	8	11		▲/▲				▲/▲
R/L111.1325.01	2.5	2.8	4.15	6.7	10.7	8	11	▲/▲	▲/▲				▲/▲
								P	o	•			•
								M	•	•			•
								K	•	•			•
								S	•	•			•
								N	•	•			•
								H					

- ▲ on stock Δ 4 weeks
- main recommendation
- o alternative recommendation
- uncoated grades
- coated grades
- brazed/Cermet

Dimensions in mm

State R or L version

Carbide grades

THREADING (internal) Partial profile



INSERT Type

111

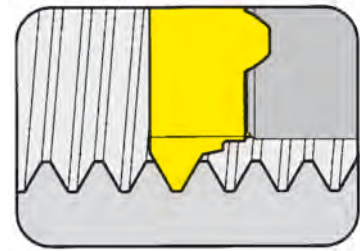

Bore Ø from Pitch .433" (11.0 mm)
0.50 - 1.75 mm

for use with Toolholder

Type 125
B111
BU111

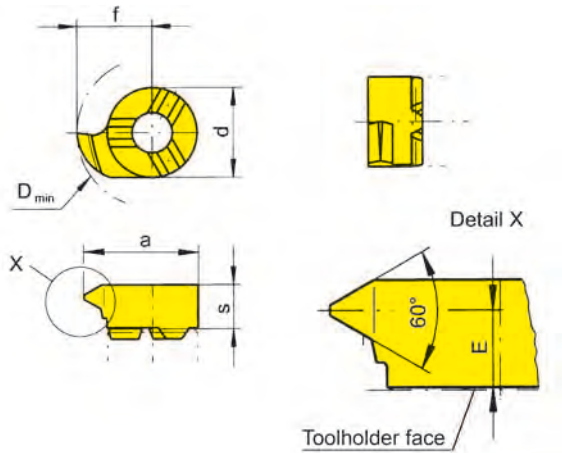

R = right hand version shown

L = left hand version

Metric ISO fine thread

Part number	P	P _{max}	E	s	f	a	d	D _{min}	Carbide grades					
									MG12	TN35	TI25	TF45	TH35	
R/L111.0205.01	0.5	0.75	3.5							▲/▲				▲/▲
R/L111.0510.01	1.0	1.25	3.3	4.15	6.7	10.7	8	11		▲/▲				▲/▲
R/L111.0815.01	1.5	1.75	3.3							▲/▲				▲/▲
										P	•			•
										M	•			•
										K	•			•
										S	•			•
										N	•			•
										H				

- ▲ on stock Δ 4 weeks
- main recommendation
- o alternative recommendation
- uncoated grades
- coated grades
- brazed/Cermet

Dimensions in mm

State R or L version

Carbide grades

THREADING (internal) Full profile



INSERT Type

111

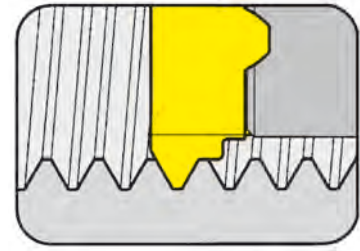

Bore Ø from Pitch .433" (11.0 mm)
2.0 - 3.0 mm

for use with Toolholder

Type 125
B111
BU111

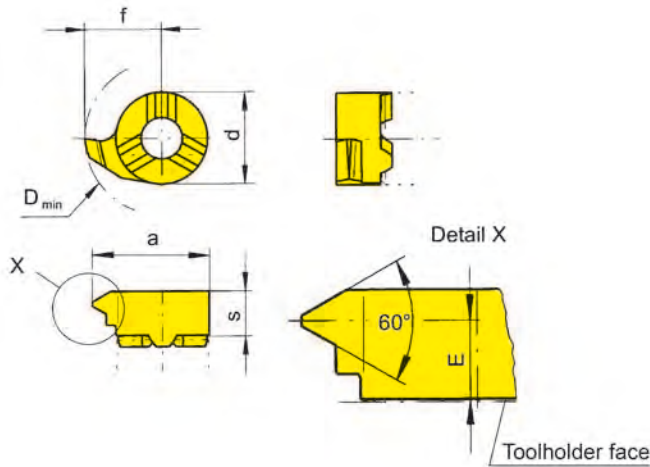

R = right hand version shown

L = left hand version

Metric ISO standard thread

Part number	P	E	s	f	a	d	D _{min}	Carbide grades						
								MG12	TN35	TI25	TF45	TH35		
R/L111.1020.02	2.0	3.0							▲/▲					
R/L111.1325.02	2.5	2.8	4.15	6.7	10.7	8	11		▲/▲					
R/L111.1630.02	3.0	2.8							▲/▲					
									●	●	●	●	●	●
									○	○	○	○	○	○
									■	■	■	■	■	■
									■	■	■	■	■	■
									■	■	■	■	■	■
									■	■	■	■	■	■

- ▲ on stock Δ 4 weeks
- main recommendation
- alternative recommendation
- uncoated grades
- coated grades
- brazed/Cermet

Dimensions in mm

State R or L version

Carbide grades

THREADING (internal) Full profile



INSERT Type

111

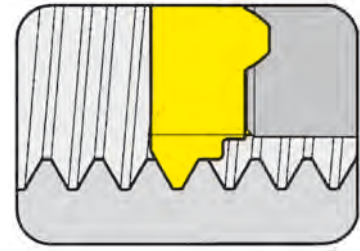

Bore Ø from Pitch .433" (11.0 mm)
1.0 - 1.5 mm

for use with Toolholder

Type 125
B111
BU111

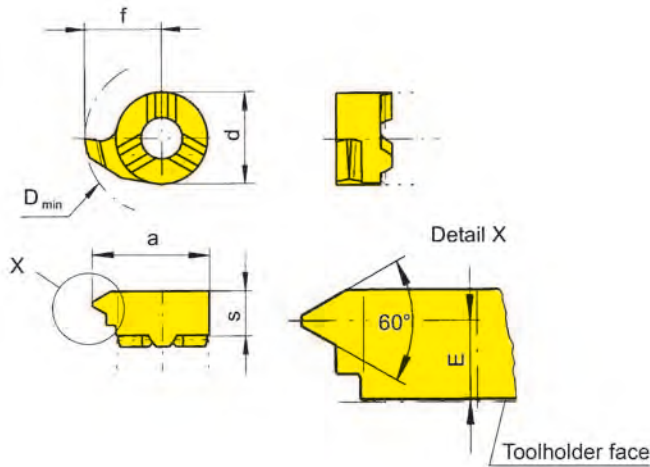

R = right hand version shown

L = left hand version

Metric ISO fine thread



Part number	P	E	s	f	a	d	D _{min}	Carbide grades					
								MG12	TN35	TI25	TF45	TH35	
R/L111.0510.02	1.0	3.3	4.15	6.7	10.7	8	11		▲/▲				
R/L111.0815.02	1.5							▲/▲					
								P	o	•			
								M	•	•			
								K	•	•			
								S	•	•			
								N	•	•			
								H					

- ▲ on stock Δ 4 weeks
- main recommendation
- o alternative recommendation
- uncoated grades
- coated grades
- brazed/Cermet

Dimensions in mm

State R or L version

Carbide grades

THREADING (internal) Partial profile



INSERT Type

111

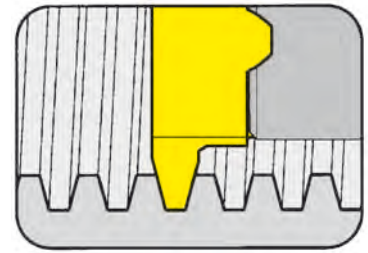

Bore Ø from Pitch .433" (11.0 mm)
1.5 - 4.0 mm

for use with Toolholder

Type 125
B111
BU111

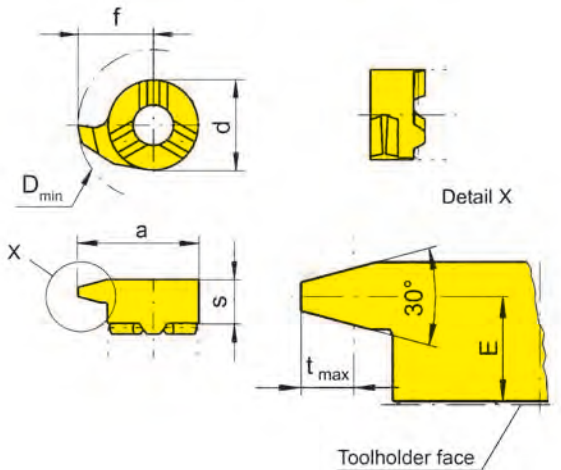

R = right hand version shown

L = left hand version

Metric ISO trapezoidal thread DIN 103

Part number	P	E	s	f	a	d	D _{min}	Carbide grades				
								MG12	TN35	TI25	TF45	TH35
R/L111.1015.01	1.5	3.5						▲/△				
R/L111.1220.01	2.0	3.3						▲/▲				
R/L111.1730.01	3.0	3.0	4.15	6.7	10.7	8	11	▲/△	▲/▲			
R/L111.2240.01	4.0	2.5						▲/▲				
								P	o	•		
								M	•	•		
								K	•	•		
								S	•	•		
								N	•	•		
								H				

- ▲ on stock △ 4 weeks
- main recommendation
- o alternative recommendation
- uncoated grades
- coated grades
- brazed/Cermet

Dimensions in mm
State R or L version

Carbide grades

THREADING (internal) Full profile



INSERT Type

111

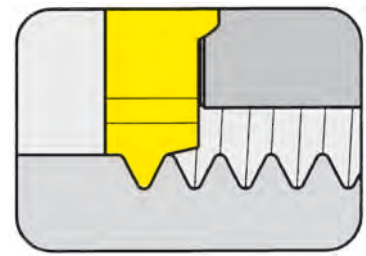

Bore Ø from	.433"
Threads per inch	14/19

for use with Toolholder

Type 125
B111
BU111

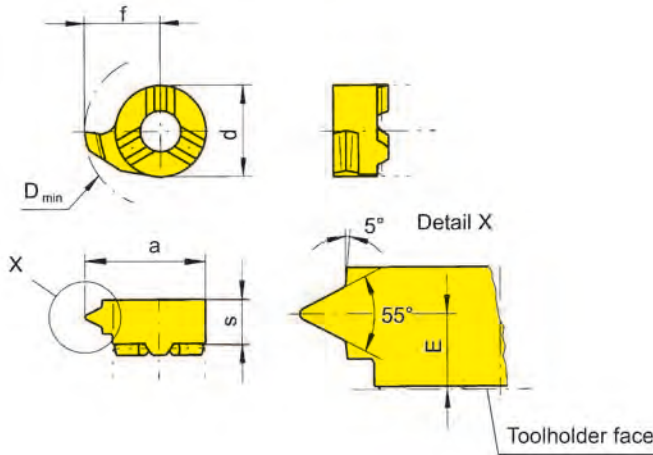

R = right hand version shown

L = left hand version

Whitworth pipe thread as per
DIN ISO 228; (259) and
2999

Part number	Threads per Inch	P	E	s	f	a	d	D _{min}	Carbide grades					
									MG12	TN35	TI25	TF45	TH35	
R/L111.5514.02	14	1.814	.098	.163	.264	.421	.315	.433		▲/▲				
R/L111.5519.02	19	1.337	.114	.163	.264	.421	.315	.433		▲/▲				
									P	•				
									M	•				
									K	•				
									S	•				
									N	•				
									H					

- ▲ on stock Δ 4 weeks
- main recommendation
- o alternative recommendation
- uncoated grades
- coated grades
- brazed/Cermet

Dimensions in inch

State R or L version

Carbide grades

HORN - THE LEADERS IN GROOVING TECHNOLOGY

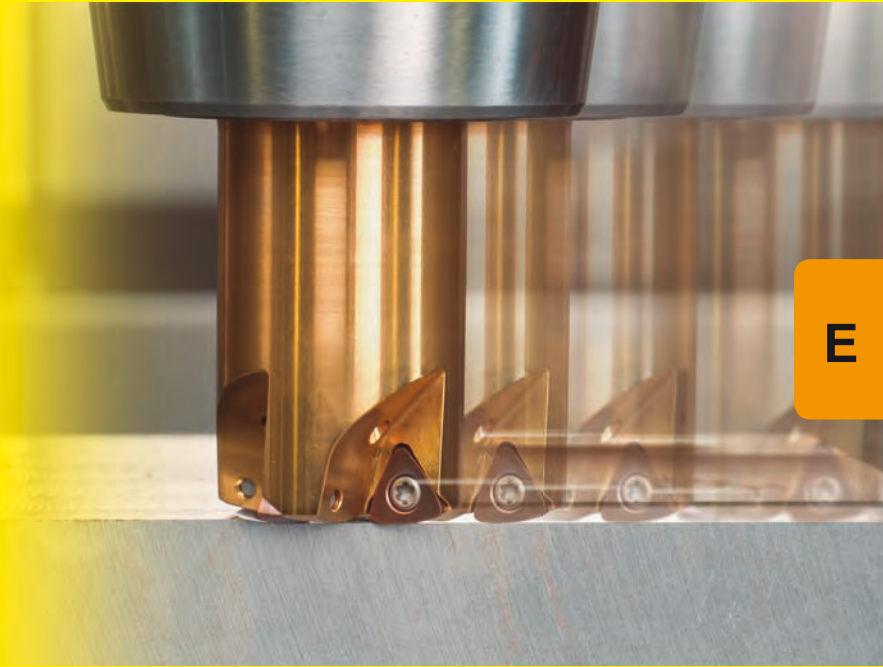

E

EXTREME FEED RATES

SYSTEM DAH

Remove material fast through high feed milling, not only for the stamping and mold industry.

HORN - INTELLIGENT TOOL DESIGN AT WORK.



For further information, please see HORN catalog "CARBIDE MILLING TOOLS".

HCG - HORN Catalog Guide

Bore Ø	Product line								
	105	110	108	10P	111	11P	114	116	18P
≥ .008" (0.2 mm)	•								
≥ .236" (6.0 mm)	•	•							
≥ .268" (6.8 mm)	•	•							
≥ .307" (7.8 mm)		•	•						
≥ .315" (8.0 mm)		•	•						
≥ .346" (8.8 mm)				•					
≥ .354" (9.0 mm)		•	•	•					
≥ .386" (9.8 mm)					•	•			
≥ .394" (10.0 mm)		•		•	•				
≥ .419" (10.5 mm)						•			
≥ .433" (11.0 mm)					•	•			
≥ .492" (12.5 mm)							•		
≥ .551" (14.0 mm)							•	•	
≥ .630" (16.0 mm)								•	
≥ .650" (16.5 mm)							•		
≥ .689" (17.5 mm)									•

Groove depth ≤ (inch)	.098"	.157"	.039"	.118"	.091"	.138"	.256"	.169"	.315"
Groove depth ≤ (mm)	2.5	4.0	1.0	3.0	2.3	3.5	6.5	4.3	8.0
Width of groove inch	.020"-.079"	.039"-.250"	.029"-.079"	.039"-.118"	.029"-.125"	.039"-.118"	.029"-.125"	.029"-.157"	.071"-.118"
Width of groove mm	0.5 - 2.0	1.0 - 6.35	0.74 - 2.0	1.0 - 3.0	0.74 - 3.18	1.0 - 3.0	0.74 - 3.18	0.74 - 4.0	1.8 - 3.0

Application	Product line								
	105	110	108	10P	111	11P	114	116	18P
Grooving	•	•	•	•	•	•	•	•	•
Boring	•	•	•	•	•	•	•	•	•
Threading	•		•		•		•	•	
Chamfering	•		•		•		•	•	
Face Grooving	•	•					•		
Hard turning	•		•		•		•	•	

Chapter	A	B	C	D	E	F	G	H	J
---------	----------	----------	----------	----------	----------	----------	----------	----------	----------

Special tools upon request

MINI CARBIDE GROOVING TOOLS

Toolholder
BU11P / B11P



Page F2-F5

Inserts
11P / S11P
≥ Ø .413" (10.5 mm)

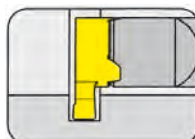

Page F6, F8



Page F7, F9



Page F10-F11

F

Technical Instructions

Page L1 - L9

TOOLHOLDER Type

BU11P

with through coolant supply

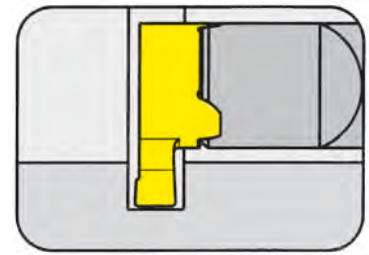

Bore Ø from	.413"
Depth of groove up to	.138"
Width of groove up to	.118"

Material of shank: Carbide - Giving a good vibration resistance

for use with Insert

Type 11P
S11P

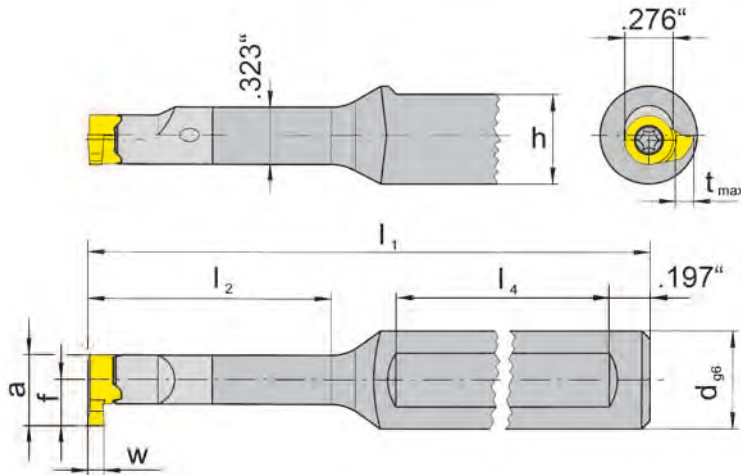

R = right hand version shown

L = left hand version

Part number	d	l ₁	l ₂	h	l ₄
R/LBU11P.0500.00		2.953	.591		1.575
R/LBU11P.0500.01	.500	3.740	1.024	.461	1.772
R/LBU11P.0500.02		4.331	1.457		1.772

State R or L version

w, a, t_{max} and f see inserts

Dimensions in inch

Further sizes upon request

Ordering note:

Toolholders with damaged seating can be repaired by HORN.

Spare parts

Toolholder	Screw	TORX PLUS® Wrench
R/LBU11P.0500.0...	3.10T9P	T9PL

TOOLHOLDER Type

B11P

with through coolant supply

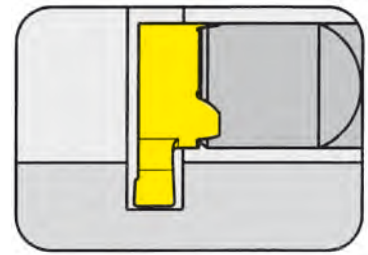

Bore Ø from	.413" (10.5 mm)
Depth of groove up to	.138" (3.5 mm)
Width of groove up to	.118" (3.0 mm)

Material of shank: Carbide - Giving a good vibration resistance

for use with Insert

Type 11P
S11P

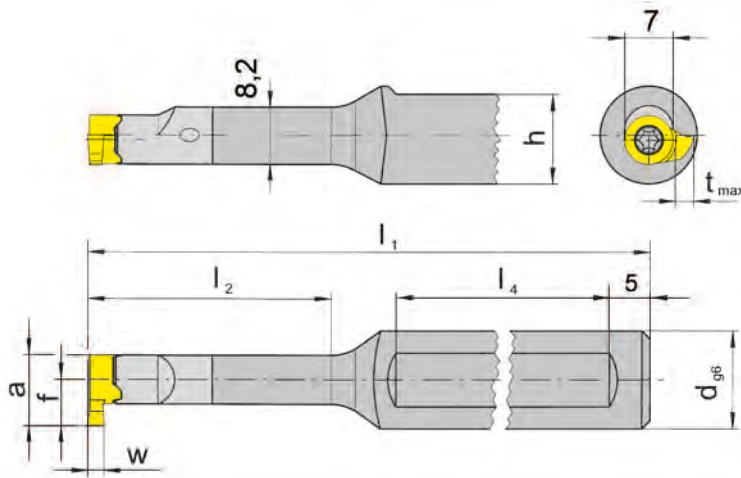

R = right hand version shown

L = left hand version

Part number	d	l ₁	l ₂	h	l ₄
R/LB11P.0012.00	12	75	15	11	40
R/LB11P.0012.01		95	26		50
R/LB11P.0012.02		110	37		50
R/LB11P.0012.03		120	50		50

State R or L version

w, a, t_{max} and f see inserts

Dimensions in mm

Further sizes upon request

Ordering note:

Toolholders with damaged seating can be repaired by HORN.

Spare parts

Toolholder	Screw	TORX PLUS® Wrench
R/LB11P.0012.0...	3.10T9P	T9PL



TOOLHOLDER Type

B11P

with through coolant supply

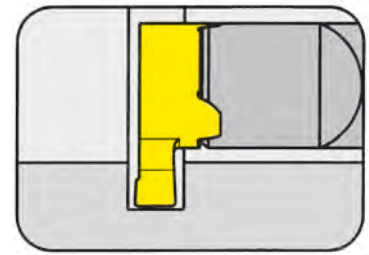

Bore Ø from	.413" (10.5 mm)
Depth of groove up to	.138" (3.5 mm)
Width of groove up to	.118" (3.0 mm)

Material of shank: Carbide - Giving a good vibration resistance

for use with Insert

Type 11P
S11P

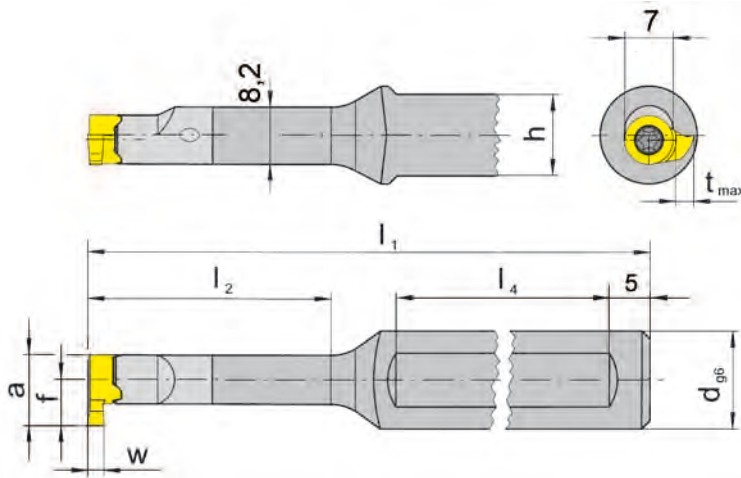

R = right hand version shown

L = left hand version

with 2 clamping flats

Part number	d	l ₁	l ₂	h	l ₄
R/LB11P.0012.2.00	12	75	15	11	40
R/LB11P.0012.2.01		95	26		50
R/LB11P.0012.2.02		110	37		50
R/LB11P.0012.2.03		120	50		50

State R or L version

w, a, t_{max} and f see inserts

Dimensions in mm

Further sizes upon request

Ordering note:

Toolholders with damaged seating can be repaired by HORN.

Spare parts

Toolholder	Screw	TORX PLUS® Wrench
R/LB11P.0012.2.0...	3.10T9P	T9PL

TOOLHOLDER Type

B11P

with through coolant supply

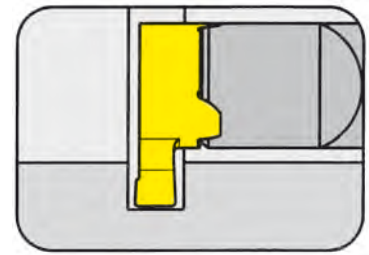

Bore Ø from	.413" (10.5 mm)
Depth of groove up to	.138" (3.5 mm)
Width of groove up to	.118" (3.0 mm)

Material of shank: Carbide - Giving a good vibration resistance

for use with Insert

Type 11P
S11P

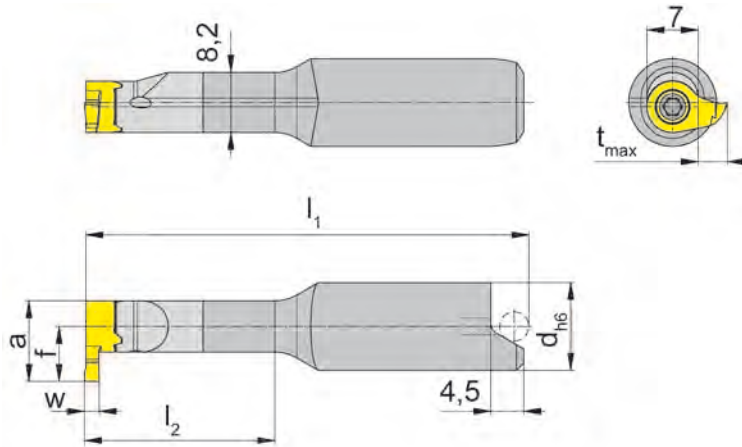

R = right hand version shown

L = left hand version

for shrinkage location
S = orientation

Part number	d	l ₁	l ₂
R/LB11P.0012.00S	12	49.7	15
R/LB11P.0012.01S		60.7	26
R/LB11P.0012.02S		71.7	37

State R or L version

w, a, t_{max} and f see inserts

Dimensions in mm

Further sizes upon request

Ordering note:

Toolholders with damaged seating can be repaired by HORN.



Example of assembly System „W&F“

Spare parts

Toolholder	Screw	TORX PLUS® Wrench
R/LB11P.0012.0...	3.10T9P	T9PL

GROOVING (internal) $\geq \text{Ø} .413''$



INSERT Type

11P

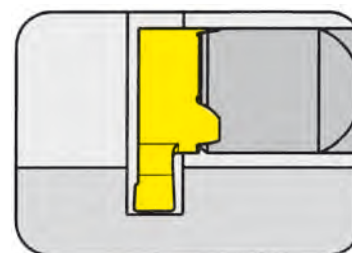

Bore Ø from	.413"
Depth of groove up to	.098"
Width of groove	.039 - .118"

for use with Toolholder

Type B11P
BU11P

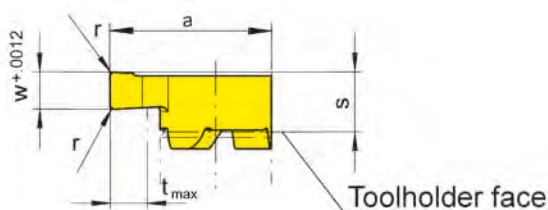
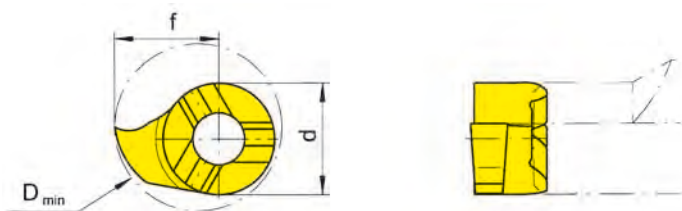

R = right hand version shown

L = left hand version

Part number	w	r	s	f	a	d	t _{max}	D _{min}	MG12	TN35	TI25	TH35
R/L11P.0100.1.00	.039	-										▲▲
R/L11P.0150.1.00	.059	-										▲▲
R/L11P.0200.1.02	.079	.008	.165	.256	.394	.276	.098	.413				▲▲
R/L11P.0250.1.02	.098	.008										▲▲
R/L11P.0300.1.02	.118	.008										▲▲

- ▲ on stock Δ 4 weeks
- main recommendation
- alternative recommendation
- uncoated grades
- coated grades
- brazed/Cermet

Carbide grades	P	M	K	S	N	H
	●	●	●	●	●	●

Dimensions in inch

State R or L version

Carbide grades

GROOVING (internal) $\geq \text{Ø} .413''$



INSERT Type

S11P

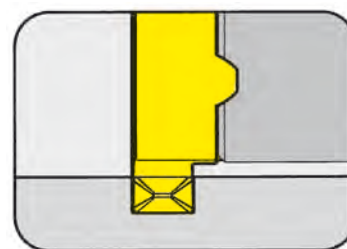

for use with Toolholder

Type B11P
BU11P

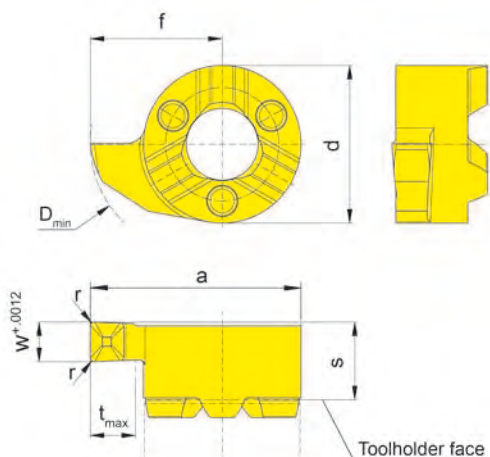

R = right hand version shown

L = left hand version

Geometry .D

Part number	w	r	s	f	a	d	t _{max}	D _{min}	Carbide grades				
									MG12	TN35	TI25	TH35	
R/LS11P.0150.1.D1	.059	.004										▲▲	●
R/LS11P.0200.1.D2	.079	.008	.165	.256	.394	.276	.098	.413				▲▲	●
R/LS11P.0250.1.D2	.098	.008										▲▲	●
												P	●
												M	●
												K	●
												S	●
												N	●
												H	●

- ▲ on stock Δ 4 weeks
- main recommendation
- alternative recommendation
- uncoated grades
- coated grades
- brazed/Cermet

Dimensions in inch

State R or L version

Carbide grades



GROOVING (internal) $\geq \text{Ø} .453''$



INSERT Type

11P

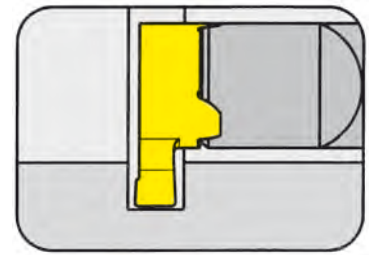

Bore Ø from	.453"
Depth of groove up to	.138"
Width of groove	.039 - .079"

for use with Toolholder

Type B11P
BU11P

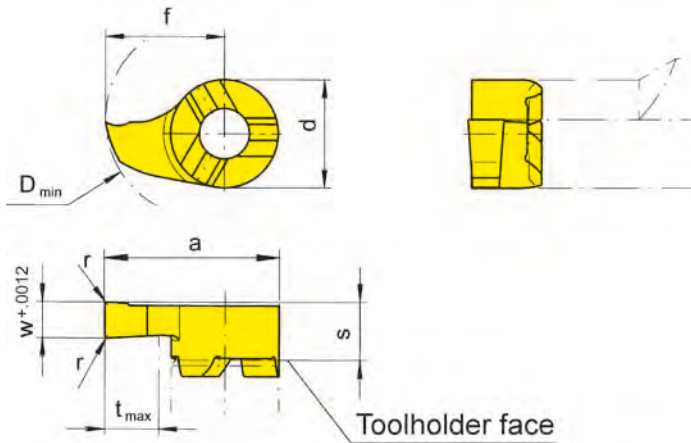

R = right hand version shown

L = left hand version

Part number	w	r	s	f	a	d	t _{max}	D _{min}	Carbide grades			
									MG12	TN35	TI25	TH35
R/L11P.0100.2.00	.039	-										▲▲
R/L11P.0150.2.00	.059	-	.165	.295	.433	.276	.138	.453				▲▲
R/L11P.0200.2.02	.079	.008										▲▲
										P		•
										M		•
										K		•
										S		•
										N		•
										H		

- ▲ on stock Δ 4 weeks
- main recommendation
- o alternative recommendation
- uncoated grades
- coated grades
- brazed/Cermet

Dimensions in inch

State R or L version

Carbide grades

GROOVING (internal) $\geq \text{Ø} .453''$



INSERT Type

S11P

Bore Ø from	.453"
Depth of groove up to	.138"
Width of groove	.059 - .098"

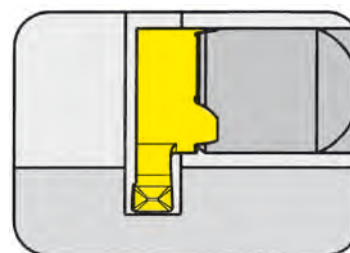

for use with Toolholder

Type B11P
BU11P

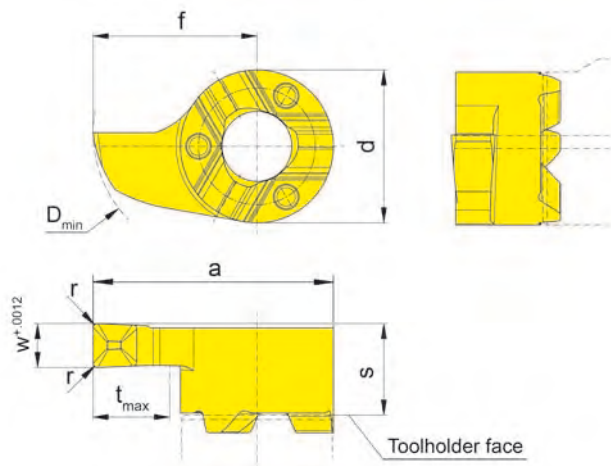

R = right hand version shown

L = left hand version

Geometry .D

Part number	w	r	s	f	a	d	t _{max}	D _{min}	Carbide grades				
									MG12	TN35	TI25	TH35	
R/LS11P.0150.2.D1	.059	.004										▲▲	●
R/LS11P.0200.2.D2	.079	.008	.165	.295	.433	.276	.138	.453				▲▲	●
R/LS11P.0250.2.D2	.098	.008										▲▲	●
										P			●
										M			●
										K			●
										S			●
										N			●
										H			

- ▲ on stock Δ 4 weeks
- main recommendation
- alternative recommendation
- uncoated grades
- coated grades
- brazed/Cermet

Dimensions in inch
State R or L version

Carbide grades



INSERT Type

11P

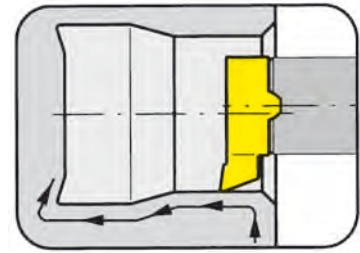

Bore Ø from $.413''$
 Depth of undercut up to $.098''$

for use with Toolholder

Type B11P
 BU11P

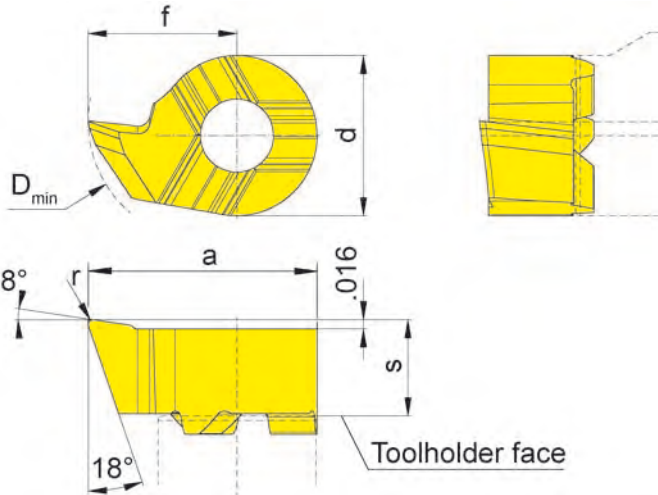

R = right hand version shown

L = left hand version

F

Part number	r	s	f	a	d	D _{min}	Carbide grades			
							MG12	TN35	TI25	TH35
R/L11P.1865.1.02	.008	.165	.256	.394	.276	.413				ΔΔ
▲ on stock Δ 4 weeks							P			•
● main recommendation							M			•
○ alternative recommendation							K			•
■ uncoated grades							S			•
■ coated grades							N			•
■ brazed/Cermet							H			•

Dimensions in inch

State R or L version

The modified geometry allows boring of bores $\geq \text{Ø} .406''$ and profiling of reliefs as per DIN 509 form E and .

INSERT Type

S11P

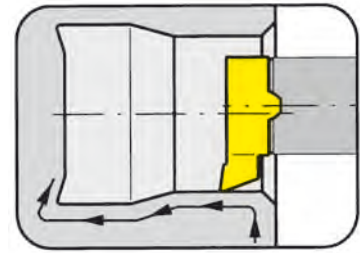

Bore \varnothing from .386''
 Depth of undercut up to .075''

for use with Toolholder

Type B11P
 BU11P

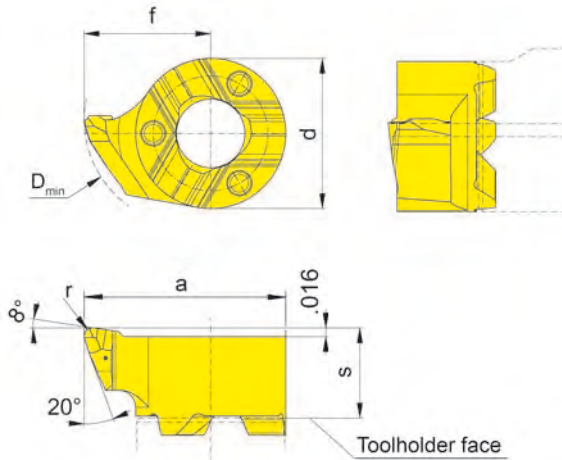

R = right hand version shown

L = left hand version

Geometry .R

F

Part number	r	s	f	a	d	D _{min}	Carbide grades			
							MG12	TN35	Ti25	TH35
LS11P.1859.R2	.008									▲
RS11P.1859.R2	.008					.386				▲
LS11P.1859.R4	.016	.165	.232	.370	.276					▲
RS11P.1859.R4	.016									▲
							P			•
							M			•
							K			•
							S			•
							N			•
							H			•

- ▲ on stock Δ 4 weeks
- main recommendation
- o alternative recommendation
- uncoated grades
- coated grades
- brazed/Cermet

Dimensions in inch
 State R or L version

The modified geometry allows boring of bores $\geq \varnothing 9,8$ mm and profiling of reliefs as per DIN 509 form E and F.

HCG - HORN Catalog Guide

Bore Ø	Product line								
	105	110	108	10P	111	11P	114	116	18P
≥ .008" (0.2 mm)	•								
≥ .236" (6.0 mm)	•	•							
≥ .268" (6.8 mm)	•	•							
≥ .307" (7.8 mm)		•	•						
≥ .315" (8.0 mm)		•	•						
≥ .346" (8.8 mm)				•					
≥ .354" (9.0 mm)		•	•	•					
≥ .386" (9.8 mm)					•	•			
≥ .394" (10.0 mm)		•		•	•				
≥ .419" (10.5 mm)						•			
≥ .433" (11.0 mm)					•	•			
≥ .492" (12.5 mm)							•		
≥ .551" (14.0 mm)							•	•	
≥ .630" (16.0 mm)								•	
≥ .650" (16.5 mm)							•		
≥ .689" (17.5 mm)									•

Groove depth ≤ (inch)	.098"	.157"	.039"	.118"	.091"	.138"	.256"	.169"	.315"
Groove depth ≤ (mm)	2.5	4.0	1.0	3.0	2.3	3.5	6.5	4.3	8.0
Width of groove inch	.020"-.079"	.039"-.250"	.029"-.079"	.039"-.118"	.029"-.125"	.039"-.118"	.029"-.125"	.029"-.157"	.071"-.118"
Width of groove mm	0.5 - 2.0	1.0 - 6.35	0.74 - 2.0	1.0 - 3.0	0.74 - 3.18	1.0 - 3.0	0.74 - 3.18	0.74 - 4.0	1.8 - 3.0

Application	Product line								
	105	110	108	10P	111	11P	114	116	18P
Grooving	•	•	•	•	•	•	•	•	•
Boring	•	•	•	•	•	•	•	•	•
Threading	•		•		•		•	•	
Chamfering	•		•		•		•	•	
Face Grooving	•	•					•		
Hard turning	•		•		•		•	•	

Chapter	A	B	C	D	E	F	G	H	J
---------	----------	----------	----------	----------	----------	----------	----------	----------	----------

Special tools upon request

MINI CARBIDE GROOVING TOOLS

Toolholder
BU114 / B114

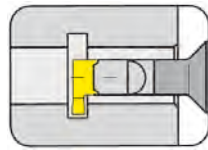

Page G2-G5

Toolholder
HCU114 / HC114

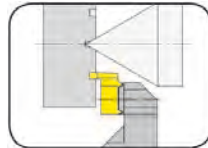

Page G6-G7

Inserts
U114 / 114 / S114
≥ Ø .551" (14.0 mm)



Page G8-G9

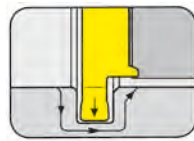

Page G10-G14

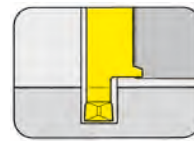

Page G15



Page G16-G17

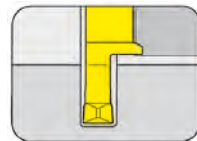

Page G18

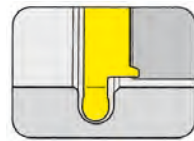

Page G20-G21



Page G22-G24

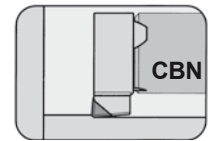

Page G25

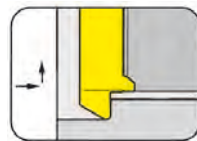

Page G26



Page G27

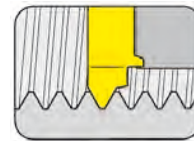

Page G28-G29

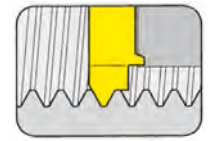

Page G30-G31

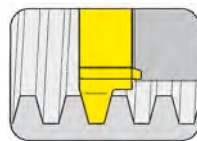

Page G30-G31

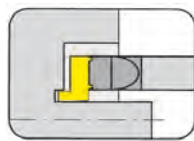

Page G34-G35

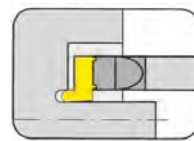

Page G36-G37

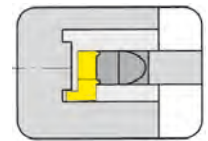

Page G38-G39

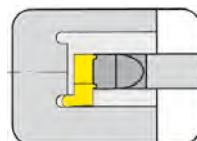

Page G40-G41

Technical Instructions

Page L1 - L9

G

TOOLHOLDER Type

BU114

with through coolant supply

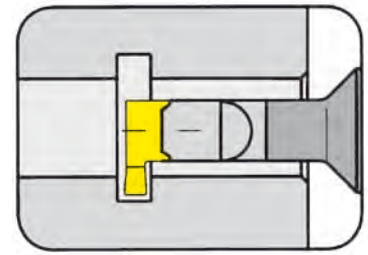

Bore Ø from	.551"
Depth of groove up to	.256"
Width of groove up to	.125"

Material of shank: Carbide - Giving a good vibration resistance

for use with Insert

Type 114
S114
U114

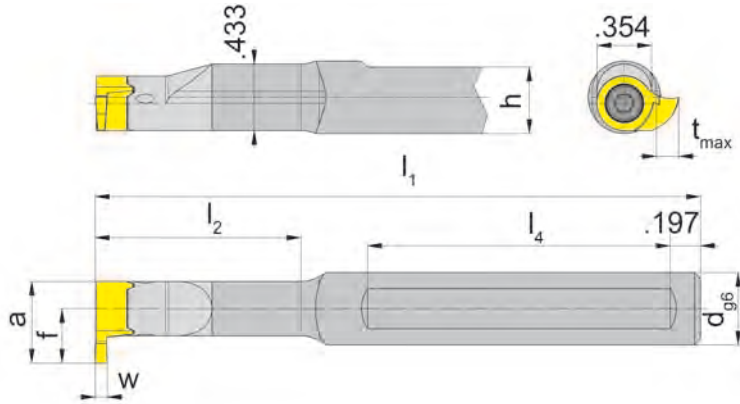

Picture = right hand cutting version shown

Part number	d	l ₁	l ₂	h	l ₄	Remark
BU114.ST05.00	.500	2.953	.748	.460	1.570	* Steel toolholder
BU114.0500.01		3.937	1.338			
BU114.0500.02	.500	4.330	1.771	.460	1.970	
BU114.0500.03		5.118	2.520			
BU114.ST06.00	.625	3.150	.748	.585	1.570	* Steel toolholder
BU114.0625.01		3.937	1.338			
BU114.0625.02	.625	4.330	1.771	.585	1.970	
BU114.0625.03		5.118	2.520			

Further sizes upon request

w, a, t_{max} and f see inserts

Dimensions in inch

Note:

Toolholders can be used in right and left hand inserts.
Toolholders with damaged seating can be repaired by HORN.

* Steel toolholder is not repairable.

Spare parts

Toolholder	Screw	TORX PLUS® Wrench
BU114....	4.12T15EP	T15PQ

TOOLHOLDER Type

B114

with through coolant supply

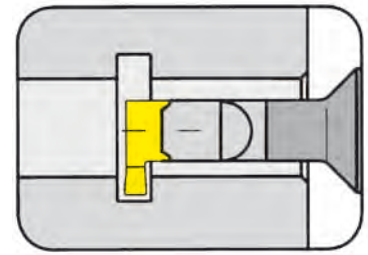

Bore Ø from	.551" (14.0 mm)
Depth of groove up to	.256" (6.5 mm)
Width of groove up to	.125" (3.18 mm)

Material of shank: Carbide - Giving a good vibration resistance

for use with Insert

Type 114
S114
U114

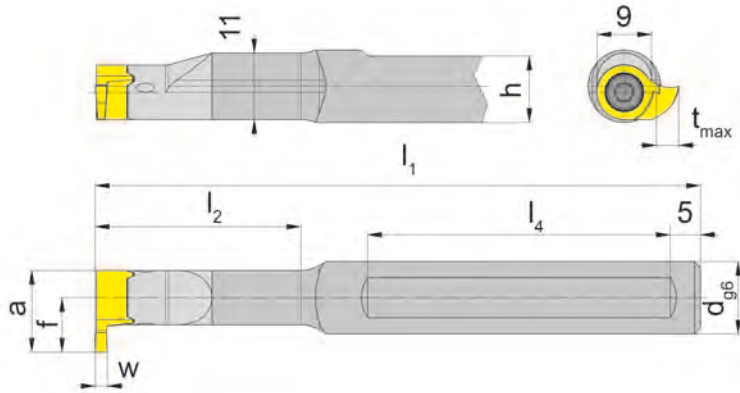

Picture = right hand cutting version shown

Part number	d	l ₁	l ₂	h	l ₄
B114.0012.00	12	75	19.5	11	40
B114.0012.01		100	34.0		50
B114.0012.02		110	45.0		50
B114.0012.03		130	64.0		50
B114.0016.00	16	80	19.5	15	40
B114.0016.01		100	34.0		50
B114.0016.02		110	45.0		50
B114.0016.03		130	64.0		50

Further sizes upon request

w, a, t_{max} and f see inserts

Dimensions in mm

Ordering note:

Toolholders can be used in right and left hand inserts.
Toolholders with damaged seating can be repaired by HORN.

Spare parts

Toolholder	Screw	TORX PLUS® Wrench
B114.001...	4.12T15EP	T15PQ



TOOLHOLDER Type

B114

with through coolant supply

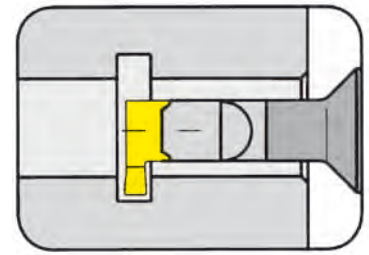

Bore Ø from	.551" (14.0 mm)
Depth of groove up to	.256" (6.5 mm)
Width of groove up to	.125" (3.18 mm)

Material of shank: Carbide - Giving a good vibration resistance

for use with Insert

Type 114
S114
U114

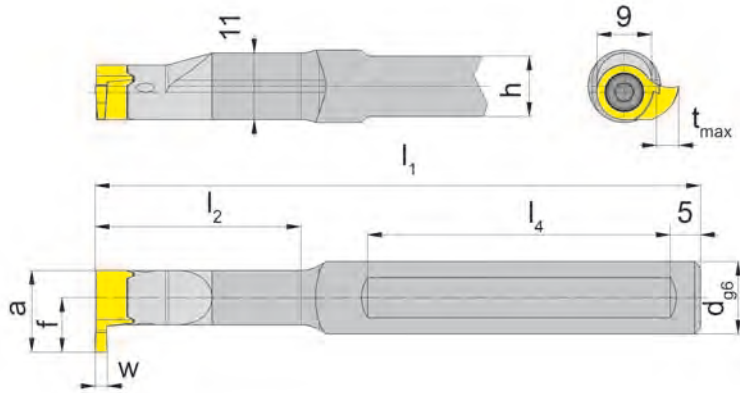

Picture = right hand cutting version shown

with 2 clamping flats

Part number	d	l ₁	l ₂	h	l ₄
B114.0012.2.00	12	75	19.5	11	40
B114.0012.2.01		100	34.0		50
B114.0012.2.02		110	45.0		50
B114.0012.2.03		130	64.0		50
B114.0016.2.00	16	80	19.5	15	40
B114.0016.2.01		100	34.0		50
B114.0016.2.02		110	45.0		50
B114.0016.2.03		130	64.0		50

Further sizes upon request

w, a, t_{max} and f see inserts

Dimensions in mm

Ordering note:

Toolholders can be used in right and left hand inserts.
Toolholders with damaged seating can be repaired by HORN.

Spare parts

Toolholder	Screw	TORX PLUS® Wrench
B114.001...	4.12T15EP	T15PQ

TOOLHOLDER Type

B114

with through coolant supply

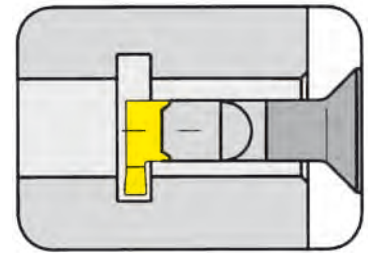

Bore Ø from	.551" (14.0 mm)
Depth of groove up to	.256" (6.5 mm)
Width of groove up to	.125" (3.18 mm)

Material of shank: Carbide - Giving a good vibration resistance

for use with Insert

Type 114
S114
U114

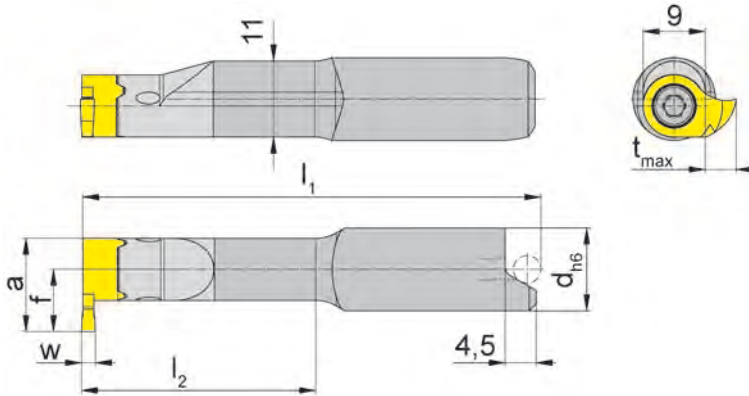

Picture = right hand cutting version shown

for shrinkage location
S = orientation

G

Part number	d	l ₁	l ₂
B114.0012.00S	12	52.7	19.5
B114.0012.01S		66.7	34.0
B114.0012.02S		77.7	45.0
B114.0012.03S		96.7	64.0

Further sizes upon request

w, a, t_{max} and f see inserts

Dimensions in mm

Ordering note:

Toolholders can be used in right and left hand inserts.
Toolholders with damaged seating can be repaired by HORN.



Example of assembly System „W&F“

Spare parts

Toolholder	Screw	TORX PLUS® Wrench
B114.0012.0...	4.12T15EP	T15PQ

TOOLHOLDER Type

HCU114

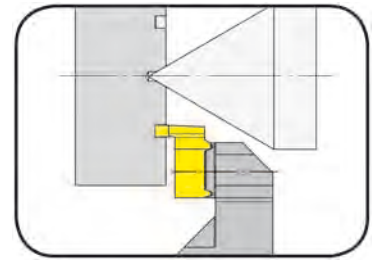

from outer groove \varnothing .472"
 Depth of groove up to .236"
 Width of groove up to .125"

for use with Insert

Type 114
 S114
 U114

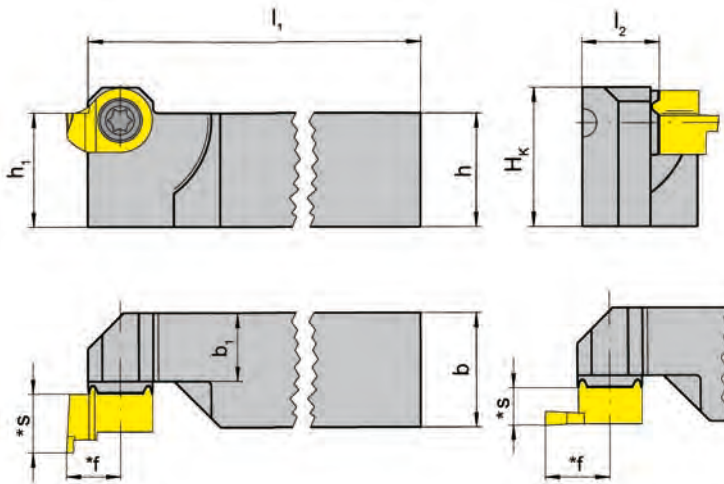

R = right hand version shown

L = left hand version

axial and radial

Part number	h	h ₁	l ₁	l ₂	b	b ₁	H _k
R/LHCU114.0500.01	.500	.500	3.819	.441	.500	.374	.642
R/LHCU114.0625.01	.625	.625	4.803	.441	.625	.374	.768
R/LHCU114.0750.01	.750	.750	4.803	.559	.750	.492	.894
R/LHCU114.1000.01	1.000	1.000	5.787	.815	1.000	.728	1.142

Further sizes upon request

* see inserts

Dimensions in inch

State R or L version

Right hand toolholders use left hand inserts.
 Left hand toolholders use right hand inserts.

Spare parts

Toolholder	Screw	TORX PLUS® Wrench
R/LHCU114....	4.12T15EP	T15PQ

TOOLHOLDER Type

HC114

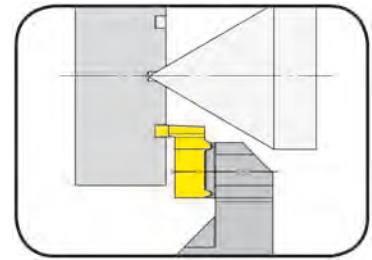

from outer groove \varnothing .472" (12.0 mm)
 Depth of groove up to .236" (6.0 mm)
 Width of groove up to .125" (3.18 mm)

for use with Insert

Type 114
 S114
 U114

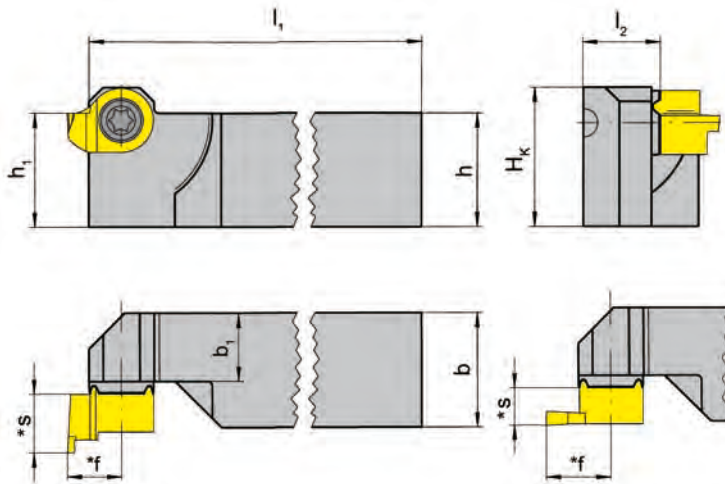

R = right hand version shown

L = left hand version

axial and radial



Part number	h	h ₁	l ₁	l ₂	b	b ₁	H _k
R/LHC114.1212.01	12	12	122	11.2	12	9.5	15.6
R/LHC114.1616.01	16	16	122	11.2	16	9.5	19.6
R/LHC114.2020.01	20	20	122	15.2	20	13.5	23.6
R/LHC114.2525.01	25	25	147	20.2	25	18.5	28.6

Further sizes upon request

* see inserts

Dimensions in mm

State R or L version

Right hand toolholders use left hand inserts.
 Left hand toolholders use right hand inserts.

Spare parts

Toolholder	Screw	TORX PLUS® Wrench
R/LHC114....	4.12T15EP	T15PQ

GROOVING (internal) $\geq \text{Ø } .551''$



INSERT Type

U114

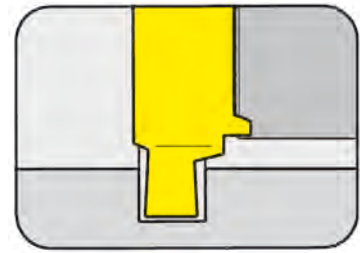

Bore Ø from	.551"
Depth of groove up to	.059"
Width of groove	.031 - .039"

for use with Toolholder

Type B114
BU114

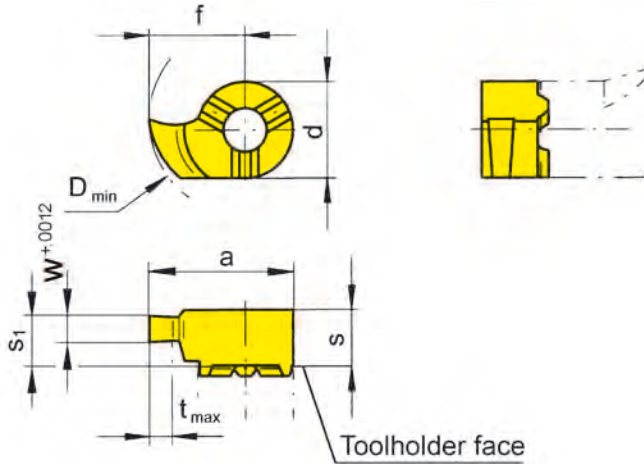

R = right hand version

L = left hand version

not face cutting,
limited depth of cut

Part number	w	s ₁	s	f	a	d	t _{max}	D _{min}	Carbide grades					
									MG12	TN35	TI25	TF45	TH35	
R/LU114.0031.00	.031	.209	.217	.354	.531	.354	.047	.551		▲/▲				
R/LU114.0039.00	.039	.209	.217	.354	.531	.354	.059	.551		▲/▲				
									P	•				
									M	•				
									K	•				
									S	•				
									N	•				
									H					

- ▲ on stock Δ 4 weeks
- main recommendation
- o alternative recommendation
- uncoated grades
- coated grades
- brazed/Cermet

Dimensions in inch

State R or L version

Depth of groove t_{max} = .059" x w

GROOVING (internal) $\geq \text{Ø} .551''$



INSERT Type

114

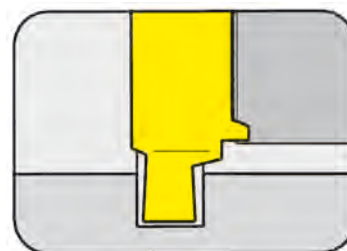

Bore Ø from	.551"
Depth of groove up to	.059"
Width of circlip Nw	.028 - .035"

Widths for circlip grooves DIN 471/472

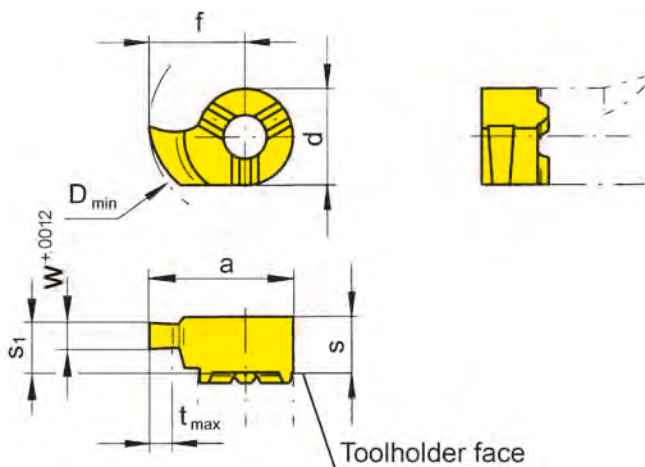

for use with Toolholder

Type B114
BU114

R = right hand version shown

L = left hand version

not face cutting,
limited depth of cut



Part number	Nw	w	s ₁	s	f	a	d	t _{max}	D _{min}	Carbide grades				
										MG12	TN35	TI25	TF45	TH35
R/L114.0070.00	.028	.029						.047	.551		▲/▲			
R/L114.0080.00	.031	.033	.209	.217	.354	.531	.354	.051	.551		▲/▲			
R/L114.0090.00	.035	.037						.059	.551		▲/▲			
											P	•		
											M	•		
											K	•		
											S	•		
											N	•		
											H			

- ▲ on stock Δ 4 weeks
- main recommendation
- o alternative recommendation
- uncoated grades
- coated grades
- brazed/Cermet

Dimensions in inch

State R or L version

Depth of groove t_{max} = .059" x w

Carbide grades

NC-PROFILING (internal) $\geq \text{Ø } .551''$



INSERT Type

U114

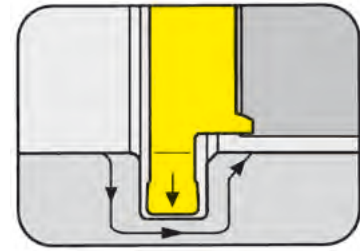

Bore Ø from	.551"
Depth of groove up to	.157"
Width of groove	.031 - .125"

for use with Toolholder

Type B114
BU114

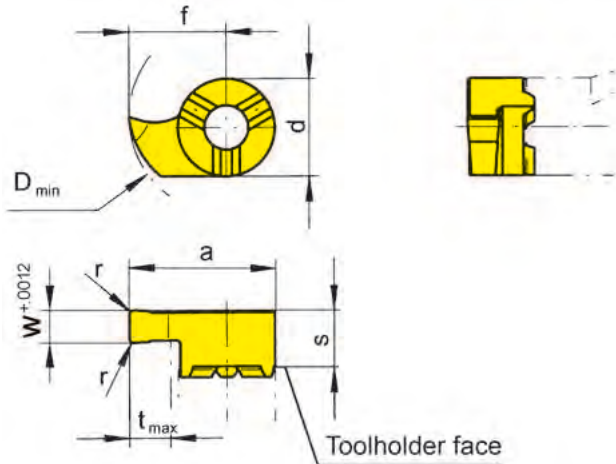

R = right hand version shown

L = left hand version

with corner radius

Part number	w	r	s	f	a	d	t _{max}	D _{min}	MG12	TN35	TI25	TF45	TH35
R/LU114.0031.08	.031									▲/▲		▲/	
R/LU114.0046.08	.046									▲/▲		▲/	
R/LU114.0062.08	.062	.008	.209	.354	.531	.354	.157	.551		▲/▲		▲/	
R/LU114.0078.08	.078									▲/▲		▲/	
R/LU114.0094.08	.094									▲/▲		▲/	
R/LU114.0125.08	.125								▲/	▲/▲	▲/		
R/LU114.0046.16	.046									▲/			
R/LU114.0062.16	.062									▲/			
R/LU114.0078.16	.078	.016	.209	.354	.531	.354	.157	.551		▲/▲			
R/LU114.0094.16	.094									▲/▲			
R/LU114.0125.16	.125								▲/	▲/▲	▲/		

- ▲ on stock Δ 4 weeks
- main recommendation
- alternative recommendation
- uncoated grades
- coated grades
- brazed/Cermet

Dimensions in inch

State R or L version

	P	M	K	S	N	H
MG12	○	●	●	●	●	●
TN35	●	●	●	●	●	●
TI25	●	●	●	●	●	●
TF45	●	●	●	●	●	●
TH35	●	●	●	●	●	●

Carbide grades

NC-PROFILING (internal) $\geq \varnothing .551''$



INSERT Type

114

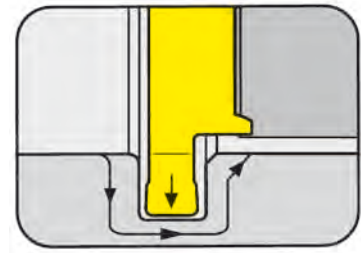

Bore \varnothing from	.551"
Depth of groove up to	.157"
Width of groove	.079"

for use with Toolholder

Type B114
BU114

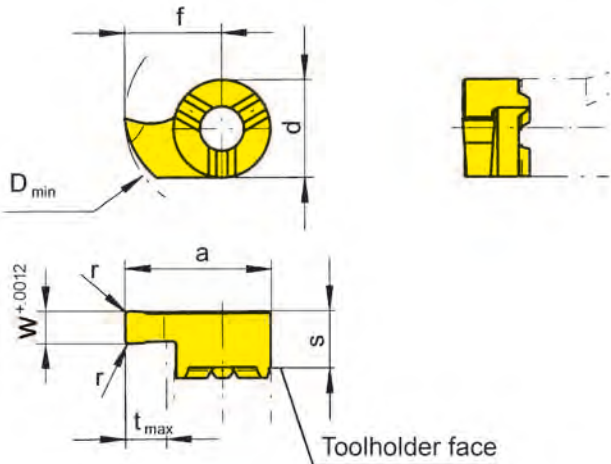

R = right hand version shown

L = left hand version

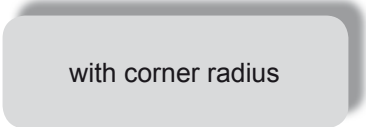

Part number	w	r	s	f	a	d	t _{max}	D _{min}	MG12	TN35	TI25	TF45	TH35
R/L114.0200.02	.079	.008	.209	.354	.531	.354	.157	.551	▲/▲	▲/▲	▲/▲		
									P	o	•	•	
									M	•	•	•	
									K	•	•	•	
									S	•	•	•	
									N	•	•	•	
									H				

Carbide grades

- ▲ on stock Δ 4 weeks
- main recommendation
- o alternative recommendation
- uncoated grades
- coated grades
- brazed/Cermet

Dimensions in inch

State R or L version

GROOVING (internal) $\geq \text{Ø} .551''$



INSERT Type

U114

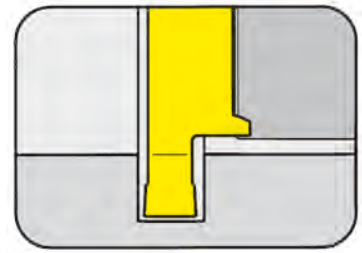

Bore Ø from	.551"
Depth of groove up to	.157"
Width of groove	.046 - .125"

for use with Toolholder

Type B114
BU114

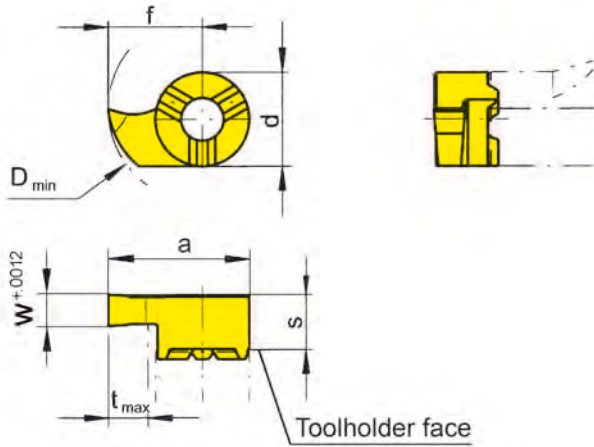

R = right hand version shown

L = left hand version

Part number	w	s	f	a	d	t _{max}	D _{min}	Carbide grades					
								MG12	TN35	TI25	TF45	TH35	
R/LU114.0046.00	.046								▲/▲				
R/LU114.0056.00	.056								/▲	▲/		Δ/	
R/LU114.0062.00	.062							/Δ	▲/▲	Δ/			
R/LU114.0078.00	.078	.209	.354	.531	.354	.157	.551	Δ/Δ	▲/▲				
R/LU114.0094.00	.094							▲/	▲/▲		▲/		
R/LU114.0125.00	.125								▲/▲				
								P	○	●	●	●	●
								M	●	●	●	●	●
								K	●	●	●	●	●
								S	●	●	●	●	●
								N	●	●	●	●	●
								H					

- ▲ on stock Δ 4 weeks
- main recommendation
- alternative recommendation
- uncoated grades
- coated grades
- brazed/Cermet

Dimensions in inch
State R or L version

Carbide grades

GROOVING (internal) $\geq \text{Ø} .551''$



INSERT Type

114

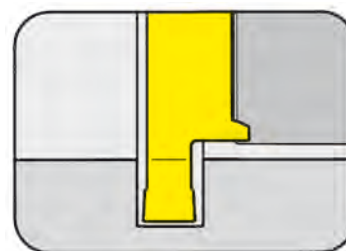

Bore Ø from	.551"
Depth of groove up to	.157"
Width of circlip Nw	.043 - .063"

Widths for circlip grooves DIN 471/472

for use with Toolholder

Type B114
BU114

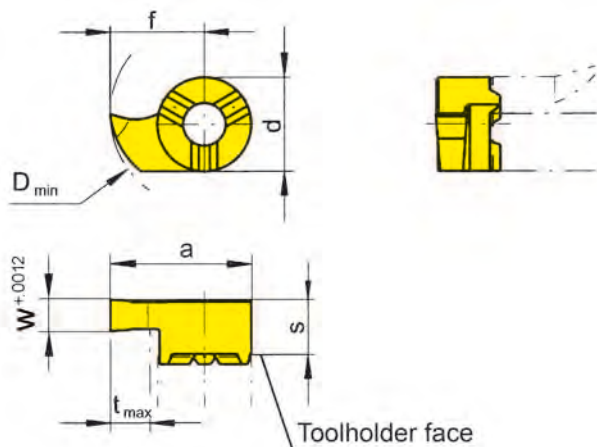

R = right hand version shown

L = left hand version

Part number	Nw	w	s	f	a	d	t _{max}	D _{min}	Carbide grades				
									MG12	TN35	TI25	TF45	TH35
R/L114.0110.00	.043	.047								▲/▲			▲/▲
R/L114.0130.00	.051	.055	.209	.354	.531	.354	.157	.551		▲/▲			▲/▲
R/L114.0160.00	.063	.067								▲/▲			▲/▲
▲ on stock Δ 4 weeks ● main recommendation ○ alternative recommendation □ uncoated grades ■ coated grades ■ brazed/Cermet										P	●	■	●
										M	●	■	●
										K	●	■	●
										S	●	■	●
										N	●	■	●
										H	■	■	■

Dimensions in inch

Carbide grades

State R or L version



GROOVING (internal) $\geq \text{Ø} .551''$



INSERT Type

114

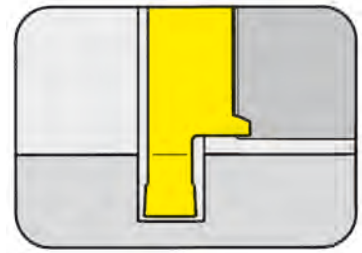

Bore Ø from	.551"
Depth of groove up to	.157"
Width of groove	.059 - .118"

for use with Toolholder

Type B114
BU114

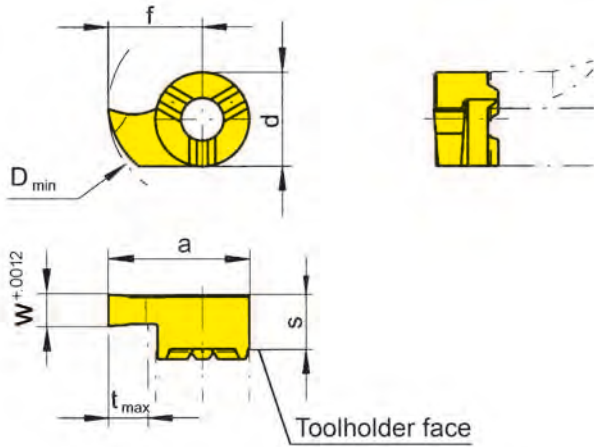

R = right hand version shown

L = left hand version

Part number	w	s	f	a	d	t _{max}	D _{min}	Carbide grades				
								MG12	TN35	TI25	TF45	TH35
R/L114.0150.00	.059							▲/▲	▲/▲			▲/▲
R/L114.0200.00	.079							▲/▲	▲/▲			▲/▲
R/L114.0250.00	.098	.209	.354	.531	.354	.157	.551	▲/▲	▲/▲			▲/▲
R/L114.0300.00	.118							▲/▲	▲/▲			▲/▲
								P	o	•		•
								M	•	•		•
								K	•	•		•
								S	•	•		•
								N	•	•		•
								H				

- ▲ on stock Δ 4 weeks
- main recommendation
- o alternative recommendation
- uncoated grades
- coated grades
- brazed/Cermet

Dimensions in inch
State R or L version

Carbide grades

GROOVING (internal) $\geq \text{Ø} .551''$



INSERT Type

S114

Bore Ø from	.551"
Depth of groove up to	.157"
Width of groove	.079"

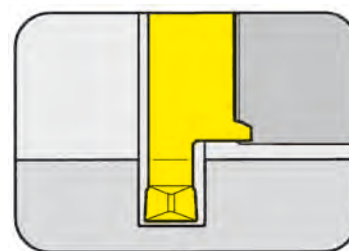

for use with Toolholder

Type B114
BU114

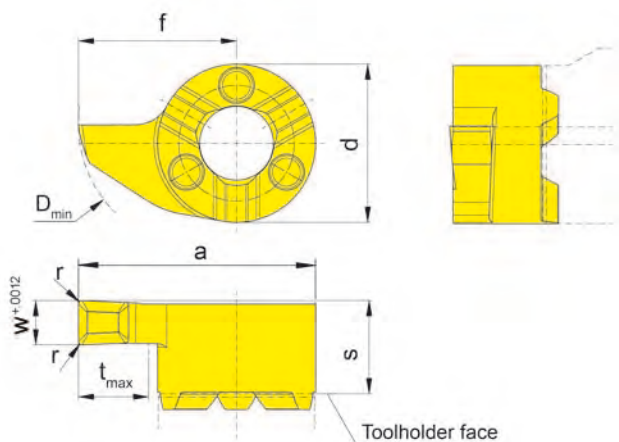

R = right hand version shown

L = left hand version

Part number	w	r	s	f	a	d	t _{max}	D _{min}	MG12	TN35	TI25	TF45	TH35
RS114.0200.D2	.079	.008	.209	.354	.531	.354	.157	.551		▲		▲	▲
									P	•	•	•	•
									M	•	•	•	•
									K	•	•	•	•
									S	•	•	•	•
									N	•	•	•	•
									H				

- ▲ on stock Δ 4 weeks
- main recommendation
- o alternative recommendation
- uncoated grades
- coated grades
- brazed/Cermet

Carbide grades

Dimensions in inch

State R or L version



GROOVING (internal) $\geq \text{Ø} .650''$



INSERT Type

U114

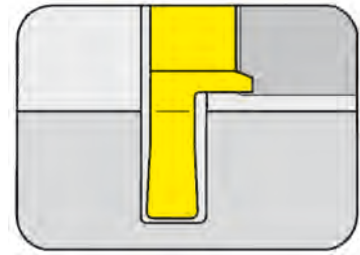

Bore Ø from	.650"
Depth of groove up to	.256"
Width of groove	.062 - .125"

for use with Toolholder

Type B114
BU114

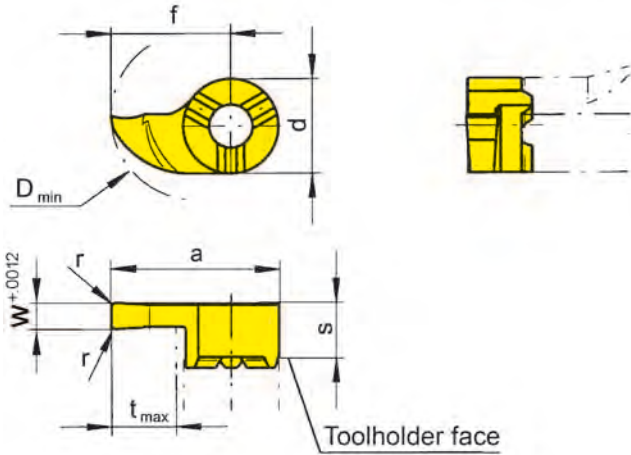

R = right hand version shown

L = left hand version

Part number	w	r	s	f	a	d	t _{max}	D _{min}	Carbide grades					
									MG12	TN35	TI25	TF45	TH35	
R/LU114.0062.1.08	.062									▲/▲				
R/LU114.0078.1.08	.078									▲/				
R/LU114.0094.1.08	.094	.008	.209	.445	.622	.354	.256	.650		▲/▲				
R/LU114.0125.1.08	.125									▲/▲				
										P	o	•		
										M	•	•		
										K	•	•		
										S	•	•		
										N	•	•		
										H				

- ▲ on stock Δ 4 weeks
- main recommendation
- o alternative recommendation
- uncoated grades
- coated grades
- brazed/Cermet

Dimensions in inch
State R or L version

Carbide grades

GROOVING (internal) $\geq \text{Ø} .650''$



INSERT Type

114

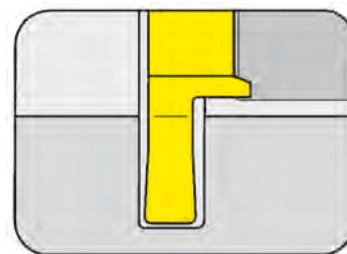

Bore Ø from	.650"
Depth of groove up to	.256"
Width of groove	.059 - .118"

for use with Toolholder

Type B114
BU114

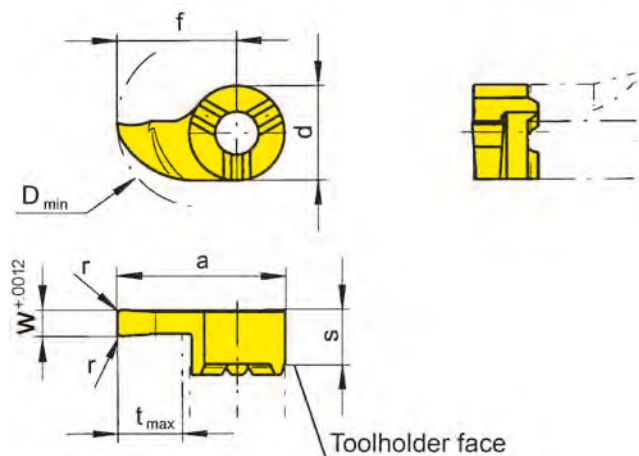

R = right hand version shown

L = left hand version

Part number	w	r	s	f	a	d	t _{max}	D _{min}	Carbide grades					
									MG12	TN35	TI25	TF45	TH35	
R/L114.0150.1.02	.059									▲/▲			▲/▲	
R/L114.0200.1.02	.079									▲/▲	▲/Δ		▲/▲	
R/L114.0250.1.02	.098	.008	.209	.445	.622	.354	.256	.650		▲/▲			▲/▲	
R/L114.0300.1.02	.118									▲/▲			▲/▲	
										P	•	•	•	•
										M	•	•	•	•
										K	•	•	•	•
										S	•	•	•	•
										N	•	•	•	•
										H				

▲ on stock Δ 4 weeks
• main recommendation
o alternative recommendation

□ uncoated grades
■ coated grades
■ brazed/Cermet

Dimensions in inch

State R or L version

Carbide grades



GROOVING (internal) $\geq \text{Ø} .650''$



INSERT Type

S114

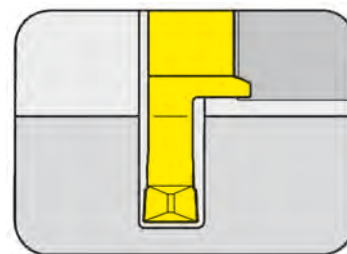

Bore Ø from	.650"
Depth of groove up to	.256"
Width of groove	.079 - .118"

for use with Toolholder

Type B114
BU114

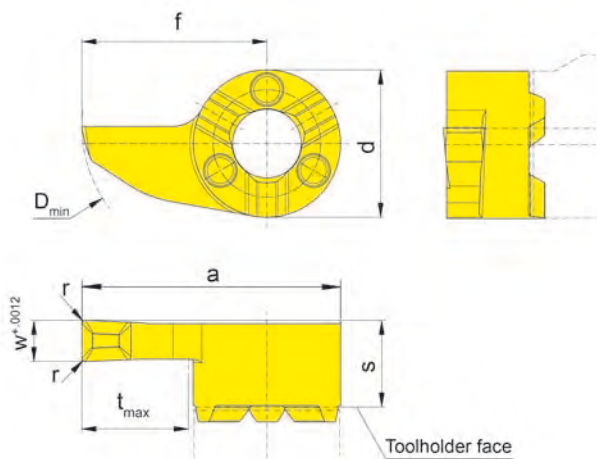

R = right hand version shown

L = left hand version

Geometry .D

Part number	w	r	s	f	a	d	t _{max}	D _{min}	Carbide grades				
									MG12	TN35	TI25	TF45	TH35
R/LS114.0200.1.D2	.079												▲▲
R/LS114.0250.1.D2	.098	.008	.209	.445	.622	.354	.256	.650					▲▲
R/LS114.0300.1.D2	.118												▲▲
									P				•
									M				•
									K				•
									S				•
									N				•
									H				•

- ▲ on stock Δ 4 weeks
- main recommendation
- o alternative recommendation
- uncoated grades
- coated grades
- brazed/Cermet

Dimensions in inch

State R or L version

Carbide grades

HORN - THE LEADERS IN GROOVING TECHNOLOGY

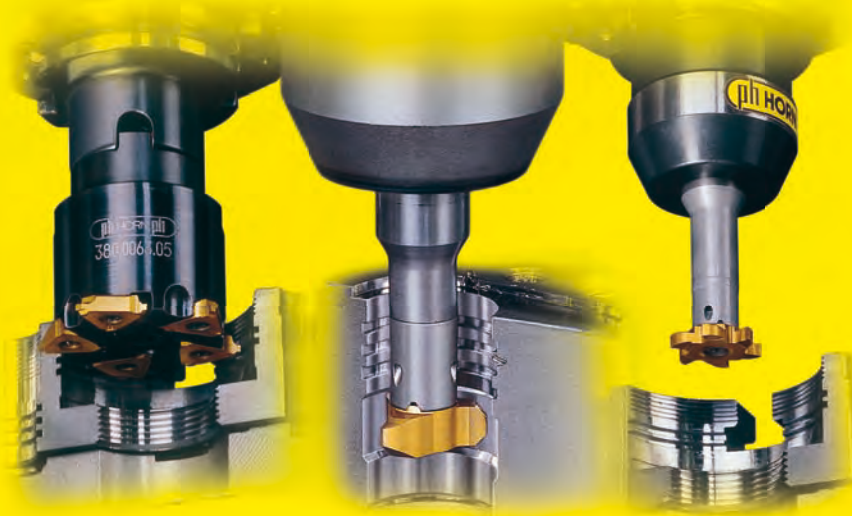

G

SETTING THE STANDARD

GROOVE MILLING

HORN groove milling sets the standard.
For productivity, nothing else come close.

HORN - INTELLIGENT TOOL DESIGN AT WORK.



For further information please see HORN catalog "CARBIDE MILLING TOOLS".

GROOVING (internal) $\geq \text{Ø} .551''$



INSERT Type

U114

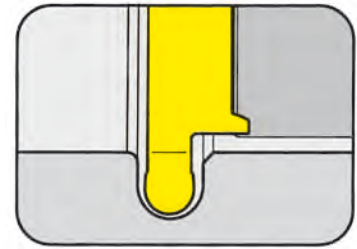

Bore Ø from	.551"
Depth of groove up to	.157"
Width of groove	.062 - .125"

for use with Toolholder

Type B114
BU114

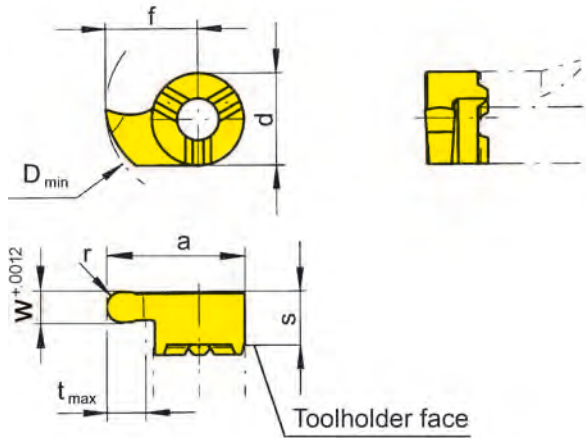

R = right hand version shown

L = left hand version

Full radius

Part number	w	r	s	f	a	d	t _{max}	D _{min}	Carbide grades					
									MG12	TN35	TI25	TF45	TH35	
R/LU114.0031.62	.062	.031								▲/▲		▲/		
R/LU114.0039.78	.078	.039								▲/▲		▲/		
R/LU114.0047.94	.094	.047	.209	.354	.531	.354	.157	.551		▲/▲		▲/		
R/LU114.0062.12	.125	.062								▲/▲		▲/		
										P	•		•	
										M	•		•	
										K	•		•	
										S	•		•	
										N	•		•	
										H				

- ▲ on stock Δ 4 weeks
- main recommendation
- o alternative recommendation
- uncoated grades
- coated grades
- brazed/Cermet

Dimensions in inch
State R or L version

Carbide grades

G

GROOVING (internal) $\geq \text{Ø } .551''$



INSERT Type

114

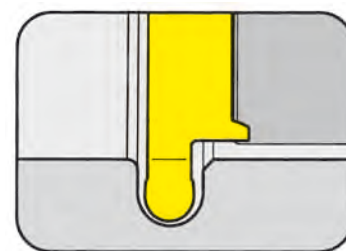

Bore Ø from	.551"
Depth of groove up to	.157"
Width of groove	.047 - .118"

for use with Toolholder

Type B114
BU114

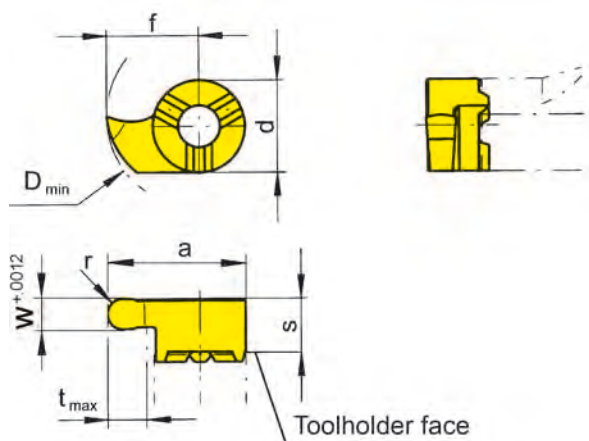

R = right hand version shown

L = left hand version

Full radius



Part number	w	r	s	f	a	d	t _{max}	D _{min}	Carbide grades				
									MG12	TN35	TI25	TF45	TH35
R/L114.0006.12	.047	.024								▲/▲			▲/▲
R/L114.0009.18	.071	.035								▲/▲			▲/▲
R/L114.0010.20	.079	.039	.209	.354	.531	.354	.157	.551		▲/▲			▲/▲
R/L114.0011.22	.087	.043								▲/▲			▲/▲
R/L114.0015.30	.118	.059								▲/▲			▲/▲

- ▲ on stock Δ 4 weeks
- main recommendation
- alternative recommendation
- uncoated grades
- coated grades
- brazed/Cermet

	P	M	K	S	N	H
MG12	●	●	●	●	●	●
TN35	●	●	●	●	●	●
TI25	●	●	●	●	●	●
TF45	●	●	●	●	●	●
TH35	●	●	●	●	●	●

Dimensions in inch

Carbide grades

State R or L version

INSERT Type

114

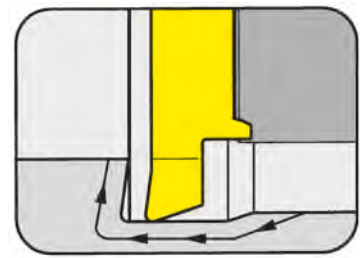

Bore Ø from $.543''$
 Depth of undercut up to $.051''$

for use with Toolholder

Type B114
 BU114

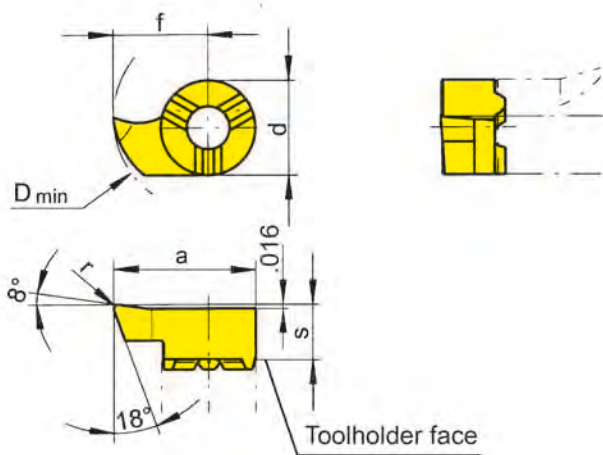

R = right hand version shown

L = left hand version

Part number	r	s	f	a	d	D _{min}	MG12	TN35	TI25	TF45	TH35
R/L114.1890.02	.008	.209	.343	.520	.354	.543	▲/▲	▲/▲			▲/▲
▲ on stock Δ 4 weeks							P	o	•		•
• main recommendation							M	•	•		•
o alternative recommendation							K	•	•		•
■ uncoated grades							S	•	•		•
■ coated grades							N	•	•		•
■ brazed/Cermet							H				

Carbide grades

Dimensions in inch

State R or L version

The modified geometry allows boring of bores $\geq \text{Ø} .543''$ and profiling of reliefs as per DIN 509 form E and .

INSERT Type

S114

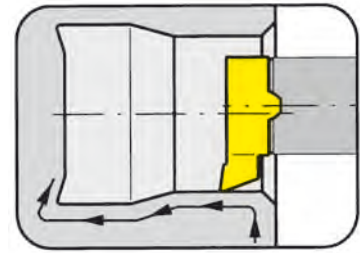

for use with Toolholder

Type B114
BU114

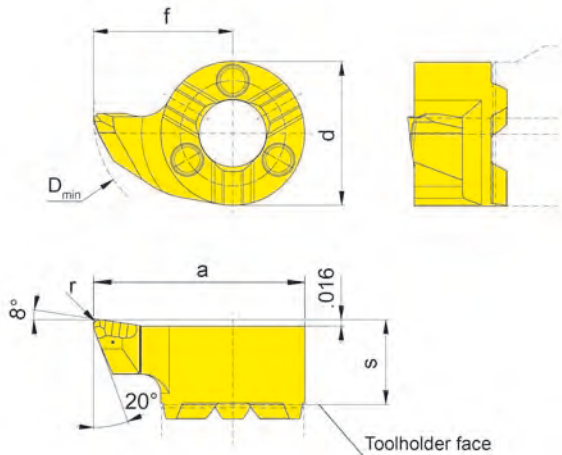

R = right hand version shown

L = left hand version

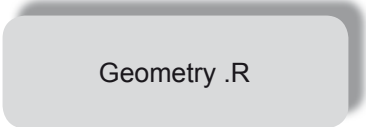

Part number	r	s	f	a	d	D _{min}	Carbide grades				
							MG12	TN35	TI25	TF45	TH35
LS114.1890.R2	.008									▲	
RS114.1890.R2	.008					.543				▲	
LS114.1890.R4	.016	.209	.343	.520	.354					▲	
RS114.1890.R4	.016									▲	
							P			•	
							M			•	
							K			•	
							S			•	
							N			•	
							H			•	

- ▲ on stock Δ 4 weeks
- main recommendation
- o alternative recommendation
- uncoated grades
- coated grades
- brazed/Cermet

Dimensions in mm

State R or L version

The modified geometry allows boring of bores $\geq \text{Ø} .543''$ and profiling of reliefs as per DIN 509 form E and F.

INSERT Type

114

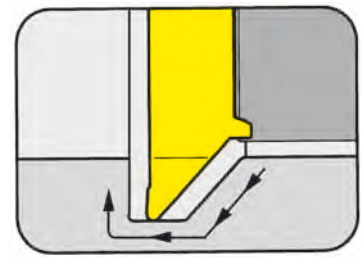

for use with Toolholder

Type B114
BU114

Bore Ø from .543''

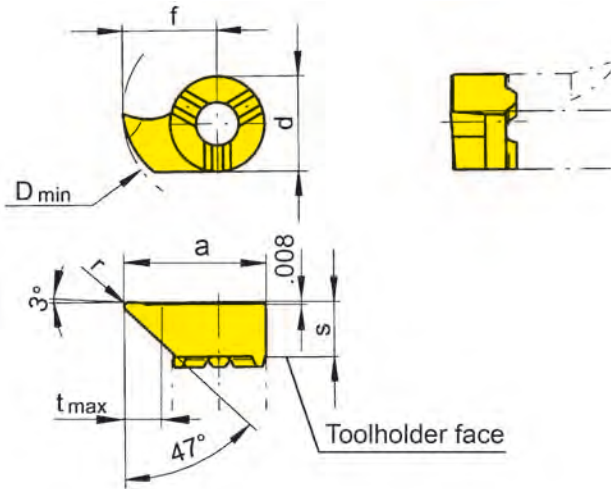

R = right hand version shown

L = left hand version

Part number	r	s	f	a	d	t _{max}	D _{min}	Carbide grades				
								MG12	TN35	TI25	TF45	TH35
R/L114.4787.02	.008	.209	.343	.520	.354	.118	.543		▲/▲			▲/▲
R/L114.4787.04	.016	.209	.343	.520	.354	.118	.543		▲/▲			▲/▲
R/L114.4710.02	.008	.209	.433	.610	.354	.197	.630		▲/▲			▲/▲
▲ on stock Δ 4 weeks ● main recommendation ○ alternative recommendation □ uncoated grades ■ coated grades ■ brazed/Cermet								P	●			●
								M	●			●
								K	●			●
								S	●			●
								N	●			●
								H				

Dimensions in inch

State R or L version

The modified geometry allows boring of bores $\geq \text{Ø} .543''$ and profiling of reliefs as per DIN 509 form E and .

INSERT Type

114

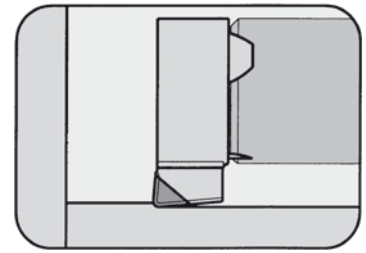

for use with Toolholder

Type B114

Bore Ø from .492"

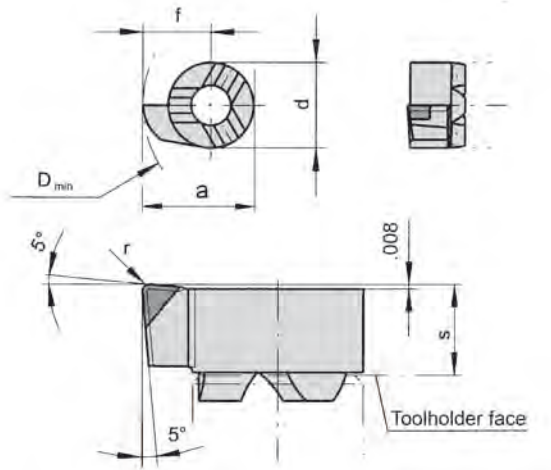

R = right hand version shown

CBN tipped



Part number	r	s	f	a	d	D _{min}		CB10
R114.0572.04.B	.016	.209	.285	.463	.354	.492		▲

▲ on stock Δ 4 weeks
 ● main recommendation
 ○ alternative recommendation
 □ uncoated grades
 ■ coated grades
 ■ brazed/Cermet

Dimensions in mm

P	■
M	■
K	■
S	■
N	■
H	●

Carbide grades

BACKBORING (internal)



INSERT Type

114

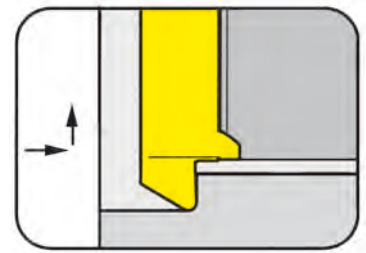

Bore Ø from .543"

for use with Toolholder

Type B114
BU114

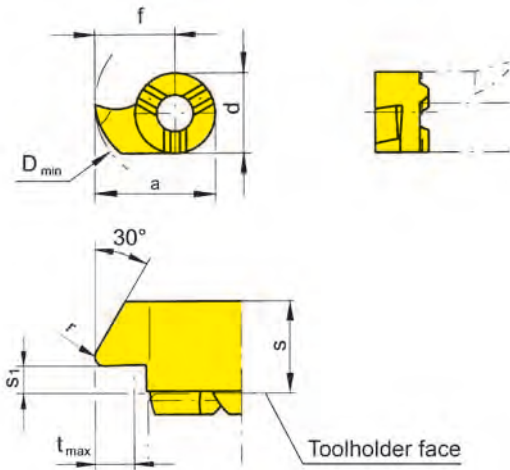

R = right hand version shown

L = left hand version

Part number	r	s ₁	s	f	a	d	t _{max}	D _{min}	MG12	TN35	TI25	TF45	TH35
R/L114.3090.02	.008	.094	.217	.343	.520	.354	.138	.543		▲/▲			▲/▲
▲ on stock Δ 4 weeks									P	•	•	•	•
● main recommendation									M	•	•	•	•
○ alternative recommendation									K	•	•	•	•
□ uncoated grades									S	•	•	•	•
■ coated grades									N	•	•	•	•
■ brazed/Cermet									H	•	•	•	•

Carbide grades

Dimensions in inch

State R or L version

INSERT Type

114

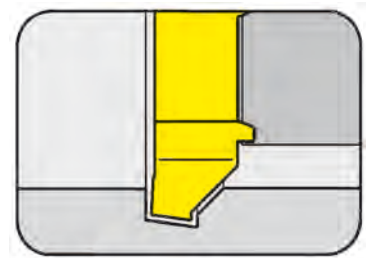

Bore Ø from .551"

for use with Toolholder

Type B114
BU114

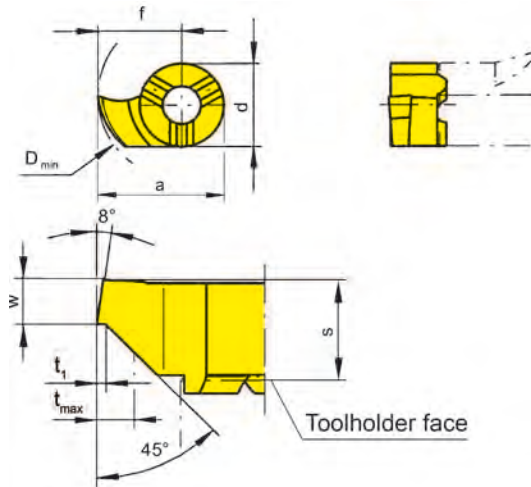

R = right hand version shown

L = left hand version



Part number	w	s	f	a	d	t ₁	t _{max}	D _{min}	MG12	TN35	TI25	TF45	TH35
R/L114.0815.45	.059	.209	.354	.531	.354	.008	.059	.551	▲/▲		▲/▲		
									P	○	●		
									M	●	●		
									K	●	●		
									S	●	●		
									N	●	●		
									H				

Carbide grades

- ▲ on stock Δ 4 weeks
- main recommendation
- alternative recommendation
- uncoated grades
- coated grades
- brazed/Cermet

Dimensions in inch

State R or L version

THREADING (internal) Partial profile



INSERT Type

114

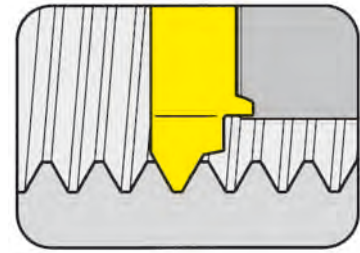

Bore Ø from Pitch .551" (14.0 mm)
2.0 - 2.5 mm

for use with Toolholder

Type B114
BU114

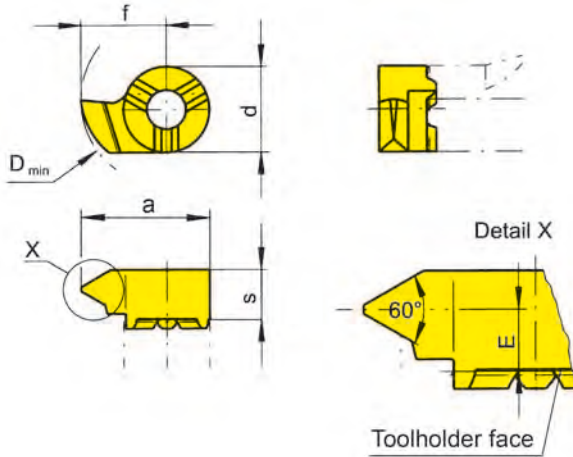

R = right hand version shown

L = left hand version

Metric ISO standard thread

Part number	P	E	s	f	a	d	D _{min}	Carbide grades				
								MG12	TN35	TI25	TF45	TH35
R/L114.1020.01	2.0	4.2	5.5	9	13.5	9	14		▲/▲			▲/▲
R/L114.1325.01	2.5							▲/Δ		▲/▲		
								P	•			•
								M	•			•
								K	•			•
								S	•			•
								N	•			•
								H				

- ▲ on stock Δ 4 weeks
- main recommendation
- o alternative recommendation
- uncoated grades
- coated grades
- brazed/Cermet

Dimensions in mm

State R or L version

Carbide grades



THREADING (internal) Partial profile



INSERT Type

114

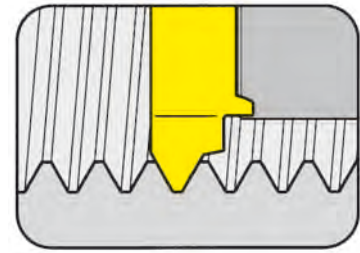

Bore Ø from Pitch .551" (14.0 mm)
0.5 - 1.5 mm

for use with Toolholder

Type B114
BU114

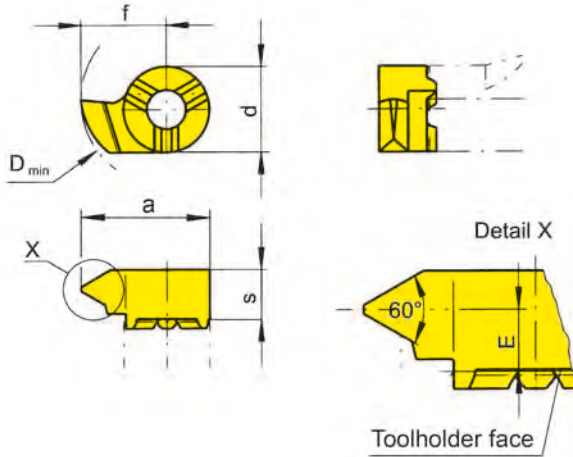

R = right hand version shown

L = left hand version

Metric ISO fine thread



Part number	P	P _{max}	E	s	f	a	d	D _{min}	Carbide grades					
									MG12	TN35	TI25	TF45	TH35	
R/L114.0205.01	0.5	0.75	4.8							▲/▲				▲/▲
R/L114.0510.01	1.0	1.25	4.7	5.5	9	13.5	9	14		▲/▲				▲/▲
R/L114.0815.01	1.5	1.75	4.5							▲/▲				▲/▲
										P	•			•
										M	•			•
										K	•			•
										S	•			•
										N	•			•
										H				

- ▲ on stock Δ 4 weeks
- main recommendation
- o alternative recommendation
- uncoated grades
- coated grades
- brazed/Cermet

Dimensions in mm

State R or L version

Carbide grades

THREADING (internal) Full profile



INSERT Type

114

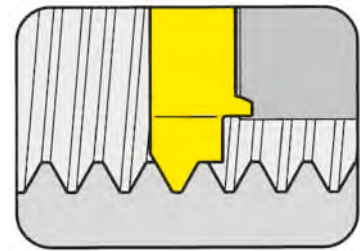

Bore Ø from Pitch .551" (14.0 mm)
2.0 - 2.5 mm

for use with Toolholder

Type B114
BU114

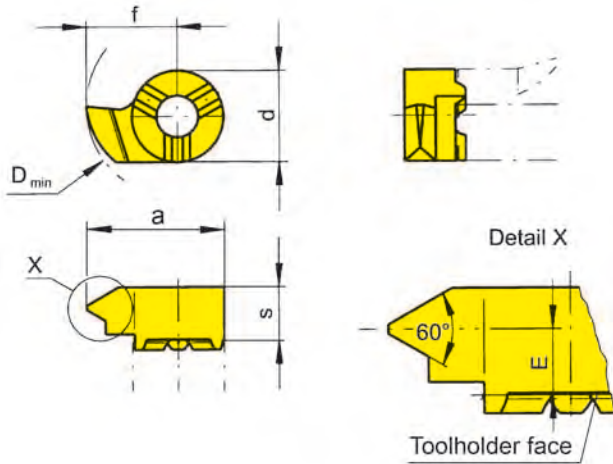

R = right hand version shown

L = left hand version

Metric ISO standard thread

Part number	P	E	s	f	a	d	D _{min}	Carbide grades				
								MG12	TN35	TI25	TF45	TH35
R/L114.1020.02	2.0	4.2	5.5	9	13.5	9	14		▲/▲			
R/L114.1325.02	2.5							▲/▲				
								P	•			
								M	•			
								K	•			
								S	•			
								N	•			
								H				

- ▲ on stock Δ 4 weeks
- main recommendation
- o alternative recommendation
- uncoated grades
- coated grades
- brazed/Cermet

Dimensions in mm

State R or L version

Carbide grades



THREADING (internal) Full profile



INSERT Type

114

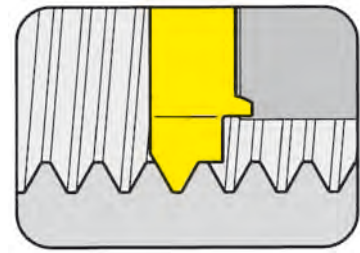

Bore Ø from Pitch .551" (14.0 mm)
1.0 - 1.5 mm

for use with Toolholder

Type B114
BU114

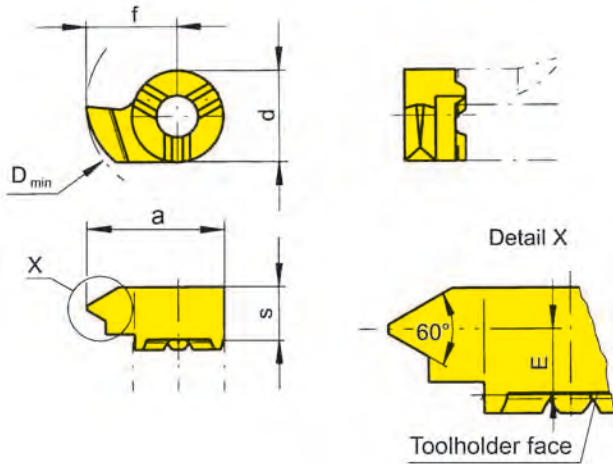

R = right hand version shown

L = left hand version

Metric ISO fine thread



Part number	P	E	s	f	a	d	D _{min}	Carbide grades				
								MG12	TN35	TI25	TF45	TH35
R/L114.0510.02	1.0	4.7	5.5	9	13.5	9	14		▲/▲			
R/L114.0815.02	1.5	4.5	5.5	9	13.5	9	14		▲/▲			
								P	•			
								M	•			
								K	•			
								S	•			
								N	•			
								H				

- ▲ on stock Δ 4 weeks
- main recommendation
- o alternative recommendation
- uncoated grades
- coated grades
- brazed/Cermet

Dimensions in mm

State R or L version

Carbide grades

THREADING (internal) Partial profile



INSERT Type

114

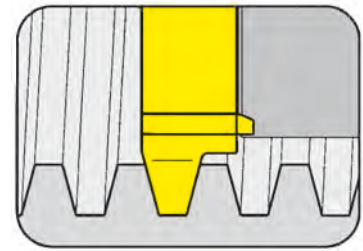

for use with Toolholder

Type B114
BU114

Bore Ø from Pitch .551" (14.0 mm)
4.0 - 5.0 mm

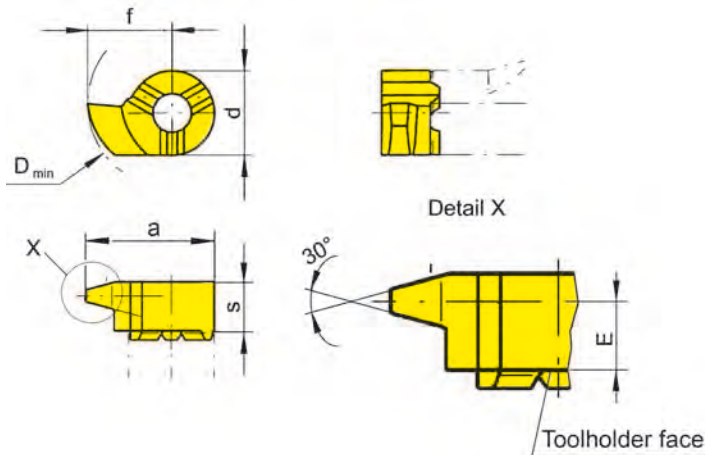

R = right hand version shown

L = left hand version

Metric ISO trapezoidal thread DIN 103

Part number	P	E	s	f	a	d	D _{min}	Carbide grades					
								MG12	TN35	TI25	TF45	TH35	
R/L114.2240.01	4	4.00	5.5	9	13.5	9	14		▲/▲				
R/L114.2750.01	5	3.55	5.5	9	13.5	9	14		▲/▲				
									●				
									●				
									○				
									■				
									■				
									■				
									■				
									■				

- ▲ on stock Δ 4 weeks
- main recommendation
- alternative recommendation
- uncoated grades
- coated grades
- brazed/Cermet

Dimensions in mm

State R or L version

Carbide grades

HORN - THE LEADERS IN GROOVING TECHNOLOGY

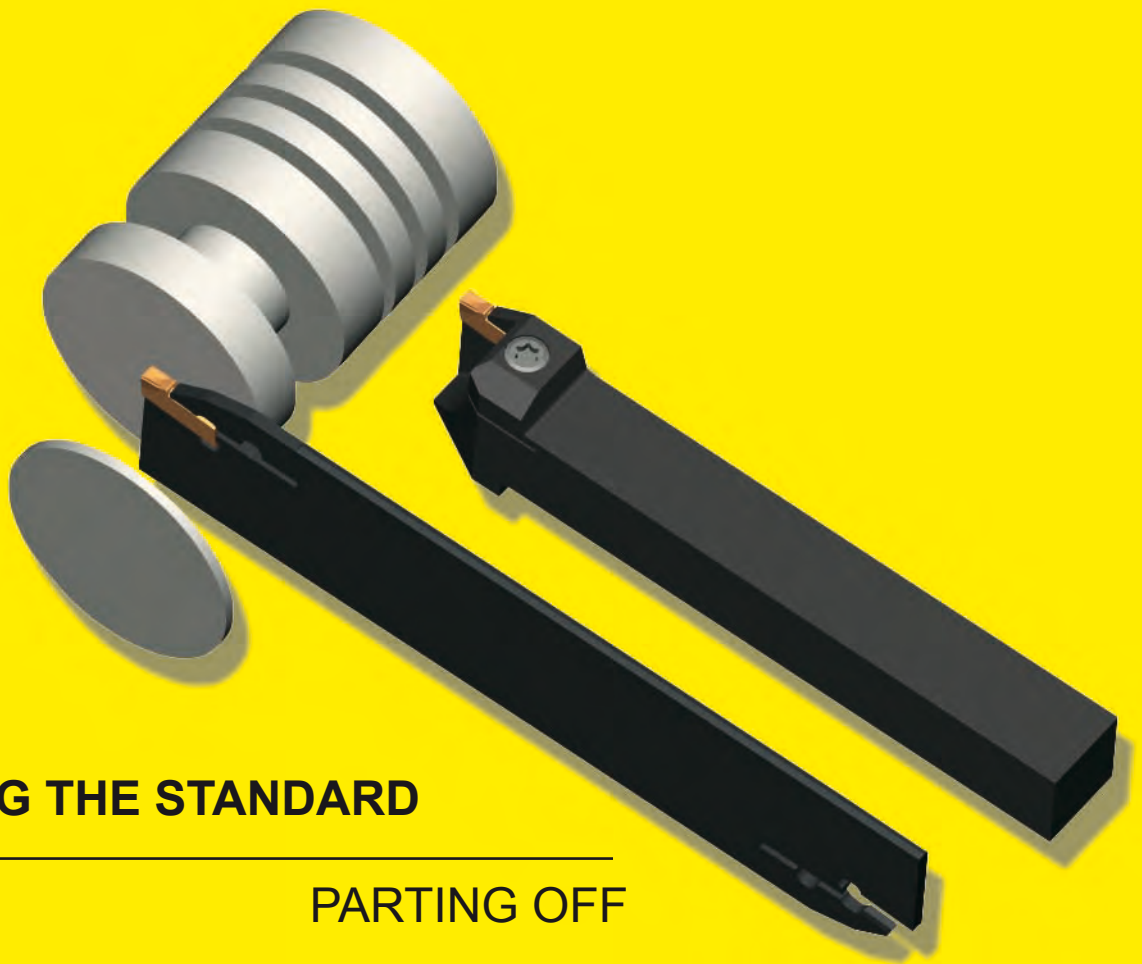

G

SETTING THE STANDARD

PARTING OFF

HORN Toolholder and blades -
with screw or self clamping.

HORN - INTELLIGENT TOOL DESIGN AT WORK.



For further information, please see HORN catalog "CARBIDE GROOVING TOOLS".

FACE GROOVING



INSERT Type

U114

from outer groove \varnothing	.472"
Depth of groove up to	.118"
Width of groove	.046 - .125"

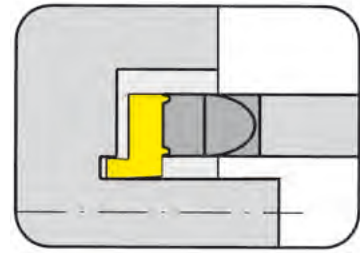

for use with Toolholder

Type B114
BU114
HC114
HCU114

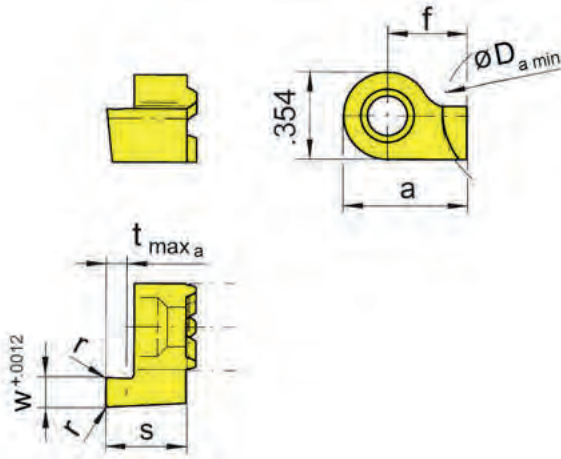

R = right hand version shown

L = left hand version

Machining **BEHIND**
centerline

Part number	w	r	s	f	a	t _{max a}	D _{a min}	MG12	TN35	TI25	TF45	TH35
R/LU114.1246.00	.046	-				.059			▲/▲			
R/LU114.1262.00	.062	.008				.098			▲/▲			
R/LU114.1278.00	.078	.008	.327	.295	.472	.118	.472		▲/▲			
R/LU114.1294.00	.094	.008				.118			▲/▲			
R/LU114.1225.00	.125	.008				.118			▲/▲			
								P	•			
								M	•			
								K	•			
								S	•			
								N	•			
								H				

Dimensions in inch

Carbide grades

State R or L version

Note:

R = rotation counter clockwise!

Using the face grooving insert type 114 on toolholder type B114 the size l_1 and l_2 will be extended by .118".

G

FACE GROOVING



INSERT Type

114

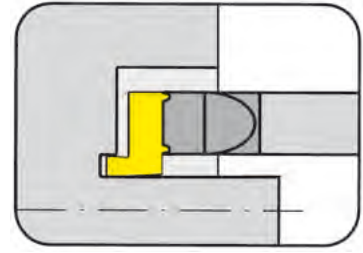

from outer groove \varnothing .472"
 Depth of groove up to .236"
 Width of groove .039 - .118"

for use with Toolholder

Type B114
 BU114
 HC114
 HCU114

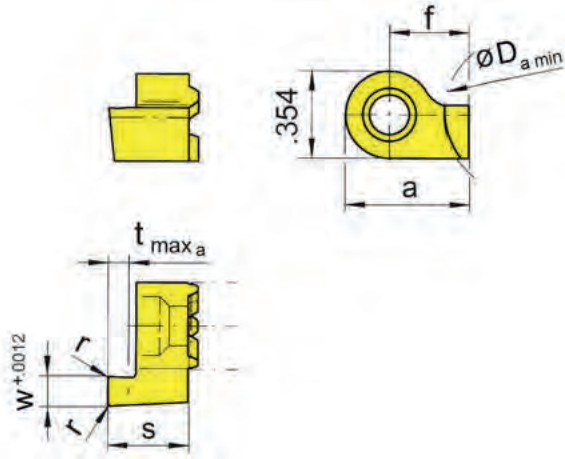

R = right hand version shown

L = left hand version

Machining **BEHIND**
 centerline



Part number	w	r	s	f	a	t _{max a}	D _{a min}	MG12	TN35	Ti25	TF45	TH35
R/L114.1210.00	.039	-				.059			▲/▲			
R/L114.1215.00	.059	.008				.098			▲/▲			
R/L114.1220.00	.079	.008	.327	.295	.472	.118	.472		▲/▲			
R/L114.1225.00	.098	.008				.118			▲/▲			
R/L114.1230.00	.118	.008				.118			▲/▲			
R/L114.1220.5.00	.079	.008	.425	.295	.472	.197	.472		▲/▲			
R/L114.1225.5.00	.098	.008							▲/▲			
R/L114.1230.6.00	.118	.008	.465	.295	.472	.236	.472		▲/▲			
								P	•			
								M	•			
								K	•			
								S	•			
								N	•			
								H				

- ▲ on stock Δ 4 weeks
- main recommendation
- o alternative recommendation
- uncoated grades
- coated grades
- brazed/Cermet

Dimensions in inch

State R or L version

Note:
 R = rotation counter clockwise!
 Using face grooving insert type 114 on toolholder type B114, the size I₁ and I₂ will be extended by:
 .118" for inserts R/L114...00
 .217" for inserts R/L114...5.00
 .256" for inserts R/L114...6.00

Carbide grades

FACE GROOVING



INSERT Type

U114

from outer groove \emptyset	.472"
Depth of groove up to	.118"
Depth of groove	.046 - .125"

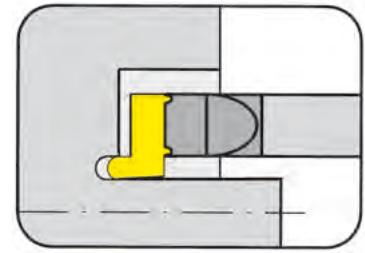

for use with Toolholder

- Type B114
 BU114
 HC114
 HCU114

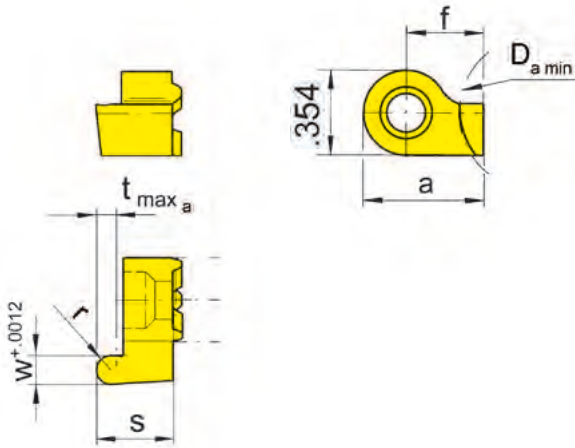

R = right hand version shown

L = left hand version

Full radius
 Machining **BEHIND**
 centerline

Part number	w	r	s	f	a	t _{max a}	D _{a min}	MG12	TN35	TI25	TF45	TH35
R/LU114.1223.46	.046	.023				.059			▲/▲			
R/LU114.1231.62	.062	.031				.098			▲/▲			
R/LU114.1239.78	.078	.039	.327	.295	.472	.118	.472		▲/▲			
R/LU114.1247.94	.094	.047				.118			▲/▲			
R/LU114.1262.12	.125	.062				.118			▲/▲			
▲ on stock Δ 4 weeks ● main recommendation ○ alternative recommendation ■ uncoated grades ■ coated grades ■ brazed/Cermet								P	•			
								M	•			
								K	•			
								S	•			
								N	•			
								H				

Dimensions in inch

Carbide grades

State R or L version

Note:

R = rotation counter clockwise!

Using the face grooving insert type 114 on toolholder type B114 the size l_1 and l_2 will be extended by .118".

G

FACE GROOVING



INSERT Type

114

from outer groove \emptyset	.472"
Depth of groove up to	.236"
Width of groove	.079 - .118"

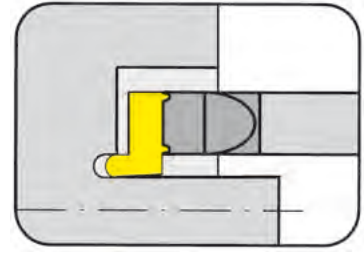

for use with Toolholder

Type B114
BU114
HC114
HCU114

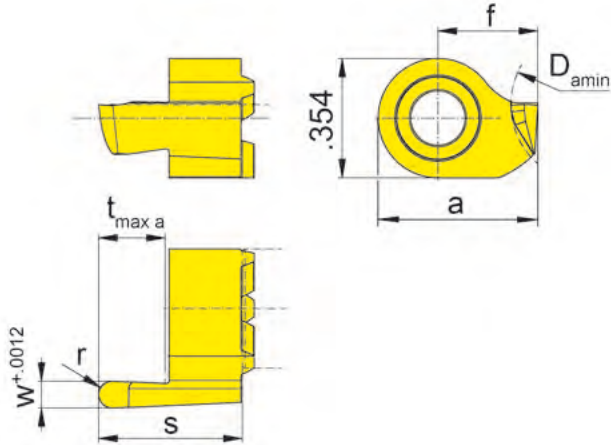

R = right hand version shown

L = left hand version

Full radius
Machining **BEHIND**
centerline



Part number	w	r	s	f	a	t _{max a}	D _{a min}	MG12	TN35	TI25	TF45	TH35
R/L114.1220.5.10	.079	.039	.425			.197			▲/▲			
R/L114.1225.5.12	.098	.049	.425	.295	.472	.197	.472		▲/▲			
R/L114.1230.6.15	.118	.059	.465			.236			▲/▲			
								P	•			
								M	•			
								K	•			
								S	•			
								N	•			
								H				

- ▲ on stock Δ 4 weeks
- main recommendation
- o alternative recommendation
- uncoated grades
- coated grades
- brazed/Cermet

Dimensions in inch

State R or L version

Note:

R = rotation counter clockwise!
Using the face grooving insert type 114 on toolholder type B114 the size I₁ and I₂ will be extended by .217" or .256".

Carbide grades

FACE GROOVING



INSERT Type

U114

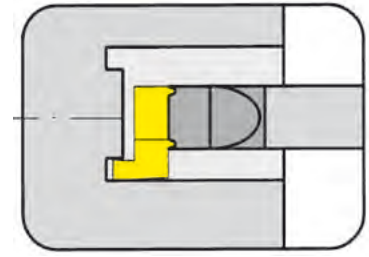

from outer groove \varnothing	.551"
Depth of groove up to	.118"
Width of groove	.046 - .125"

for use with Toolholder

Type B114
BU114
HC114
HCU114

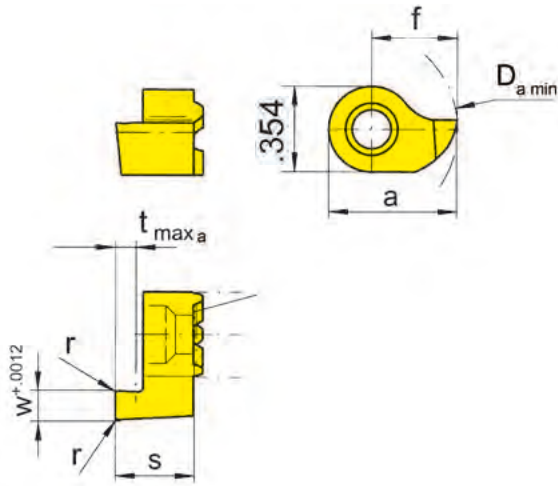

R = right hand version shown

L = left hand version

Machining **IN-FRONT**
of centerline

Part number	w	r	s	f	a	t _{max a}	D _{a min}		MG12	TN35	TI25	TF45	TH35
R/LU114.1446.00	.046	-				.059				▲/▲			
R/LU114.1462.00	.062	.008				.098				▲/▲			
R/LU114.1478.00	.078	.008	.327	.354	.531	.118	.551			▲/▲			
R/LU114.1494.00	.094	.008				.118				▲/▲			
R/LU114.1425.00	.125	.008				.118				▲/▲			
									P	•			
									M	•			
									K	•			
									S	•			
									N	•			
									H				

Dimensions in inch

Carbide grades

State R or L version

Note:

R = rotation clockwise!

Using the face grooving insert type 114 on toolholder type B114 the size l_1 and l_2 will be extended by .118".

G

FACE GROOVING



INSERT Type

114

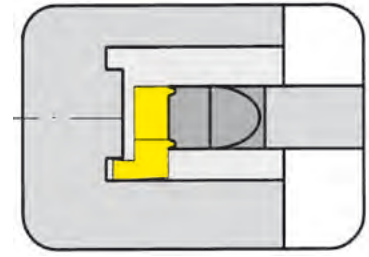

from outer groove \varnothing .551"
 Depth of groove up to .236"
 Width of groove .039 - .118"

for use with Toolholder

Type B114
 BU114
 HC114
 HCU114

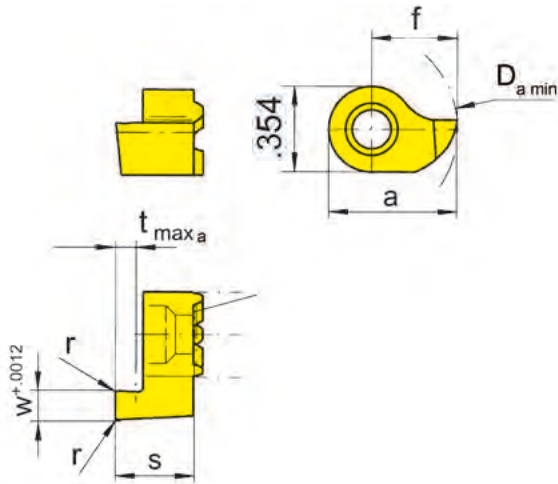

R = right hand version shown

L = left hand version

Machining **IN-FRONT**
 of centerline



Part number	w	r	s	f	a	t _{max a}	D _{a min}		MG12	TN35	Ti25	TF45	TH35
R/L114.1410.00	.039	-				.059			▲/	▲/▲			
R/L114.1415.00	.059	.008				.098				▲/▲			
R/L114.1420.00	.079	.008	.327	.354	.531	.118	.551			▲/▲			
R/L114.1425.00	.098	.008				.118				▲/▲			
R/L114.1430.00	.118	.008				.118			▲/	▲/▲			
R/L114.1420.5.00	.079	.008	.425	.354	.531	.197	.551			▲/▲			
R/L114.1425.5.00	.098	.008								▲/▲			
R/L114.1430.6.00	.118	.008	.465	.354	.531	.236	.551			▲/▲			

- ▲ on stock Δ 4 weeks
- main recommendation
- alternative recommendation
- uncoated grades
- coated grades
- brazed/Cermet

P	○	●			
M	●	●			
K	●	●			
S	●	●			
N	●	●			
H					

Carbide grades

Dimensions in inch

State R or L version

Note:

R = rotation clockwise!
 Using face grooving insert type 114 on toolholder type B114, the size l_1 and l_2 will be extended by:
 .118" for inserts R/L114...00
 .217" for inserts R/L114...5.00
 .256" for inserts R/L114...6.00

FACE GROOVING



INSERT Type

U114

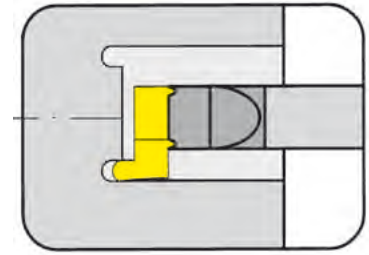

from outer groove \varnothing	.551"
Depth of groove up to	.118"
Width of groove	.046 - .125"

for use with Toolholder

- Type B114
BU114
HC114
HCU114

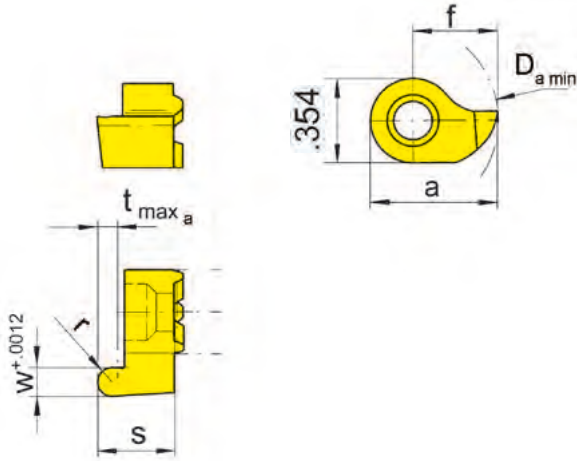

R = right hand version shown

L = left hand version

Full radius
Machining **IN-FRONT**
of centerline

Part number	w	r	s	f	a	t _{max a}	D _{a min}		MG12	TN35	TI25	TF45	TH35
R/LU114.1423.46	.046	.023				.059				▲/			
R/LU114.1431.62	.062	.031				.098				▲/▲			
R/LU114.1439.78	.078	.039	.327	.354	.531	.118	.551			▲/▲			
R/LU114.1447.94	.094	.047				.118				▲/▲			
R/LU114.1462.12	.125	.062				.118				▲/▲			
									P	•			
									M	•			
									K	•			
									S	•			
									N	•			
									H				

Dimensions in inch

Carbide grades

State R or L version

Note:

R = rotation clockwise!

Using the face grooving insert type 114 on toolholder type B114 the size l_1 and l_2 will be extended by .118".

G

FACE GROOVING



INSERT Type

114

from outer groove \varnothing	.551"
Depth of groove up to	.118"
Width of groove	.039 - .118"

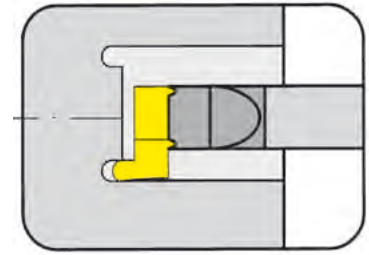

for use with Toolholder

Type B114
BU114
HC114
HCU114

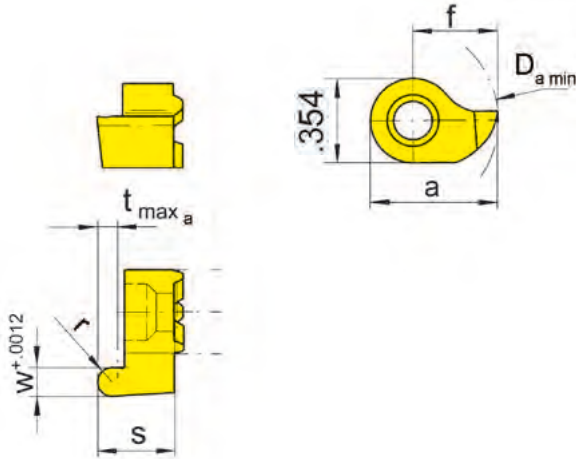

R = right hand version shown

L = left hand version

Full radius
Machining **IN-FRONT**
of centerline



Part number	w	r	s	f	a	t _{max a}	D _{a min}	Carbide grades					
								MG12	TN35	TI25	TF45	TH35	
R/L114.1410.05	.039	.020				.059			▲/▲				
R/L114.1416.08	.063	.031				.098			▲/▲				
R/L114.1420.10	.079	.039	.327	.354	.531	.118	.551		▲/▲				
R/L114.1425.12	.098	.049				.118			▲/▲				
R/L114.1430.15	.118	.059				.118			▲/▲				
▲ on stock Δ 4 weeks ● main recommendation ○ alternative recommendation ■ uncoated grades ■ coated grades ■ brazed/Cermet								P	•				
								M	•				
								K	•				
								S	•				
								N	•				
								H					

Dimensions in inch

Carbide grades

State R or L version

Note:

R = rotation clockwise!

Using the face grooving insert type 114 on toolholder type B114 the size l_1 and l_2 will be extended by .118".

HCG - HORN Catalog Guide

Bore Ø	Product line								
	105	110	108	10P	111	11P	114	116	18P
≥ .008" (0.2 mm)	•								
≥ .236" (6.0 mm)	•	•							
≥ .268" (6.8 mm)	•	•							
≥ .307" (7.8 mm)		•	•						
≥ .315" (8.0 mm)		•	•						
≥ .346" (8.8 mm)				•					
≥ .354" (9.0 mm)		•	•	•					
≥ .386" (9.8 mm)					•	•			
≥ .394" (10.0 mm)		•		•	•				
≥ .419" (10.5 mm)						•			
≥ .433" (11.0 mm)					•	•			
≥ .492" (12.5 mm)							•		
≥ .551" (14.0 mm)							•	•	
≥ .630" (16.0 mm)								•	
≥ .650" (16.5 mm)							•		
≥ .689" (17.5 mm)									•

Groove depth ≤ (inch)	.098"	.157"	.039"	.118"	.091"	.138"	.256"	.169"	.315"
Groove depth ≤ (mm)	2.5	4.0	1.0	3.0	2.3	3.5	6.5	4.3	8.0
Width of groove inch	.020"-.079"	.039"-.250"	.029"-.079"	.039"-.118"	.029"-.125"	.039"-.118"	.029"-.125"	.029"-.157"	.071"-.118"
Width of groove mm	0.5 - 2.0	1.0 - 6.35	0.74 - 2.0	1.0 - 3.0	0.74 - 3.18	1.0 - 3.0	0.74 - 3.18	0.74 - 4.0	1.8 - 3.0

Application	Product line								
	105	110	108	10P	111	11P	114	116	18P
Grooving	•	•	•	•	•	•	•	•	•
Boring	•	•	•	•	•	•	•	•	•
Threading	•		•		•		•	•	
Chamfering	•		•		•		•	•	
Face Grooving	•	•					•		
Hard turning	•		•		•		•	•	

Chapter	A	B	C	D	E	F	G	H	J
---------	----------	----------	----------	----------	----------	----------	----------	----------	----------

Special tools upon request

MINI CARBIDE GROOVING TOOLS

Toolholder
BU116 / B116

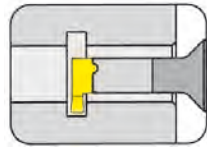

Page H2-H4

Toolholder
R/L145

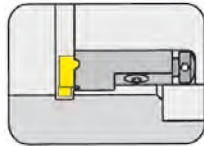

Page H5

Inserts
U116 / 116 / S116
≥ Ø .630" (16.0 mm)



Page H6-H7

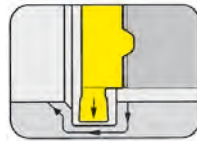

Page H8-H12

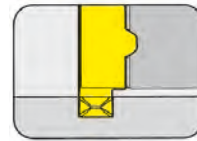

Page H13

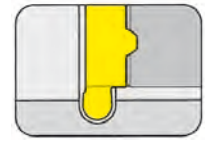

Page H14-H15

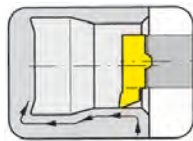

Page H16-H18

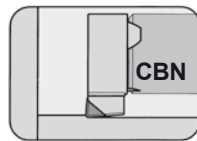

Page H19

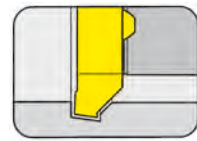

Page H20

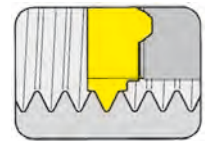

Page H22-H23

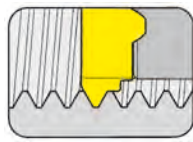

Page H24-H25

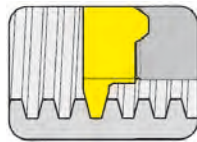

Page H26-H27

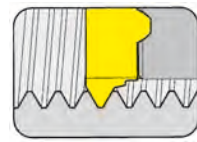

Page H28

H

TOOLHOLDER Type

BU116

with through coolant supply

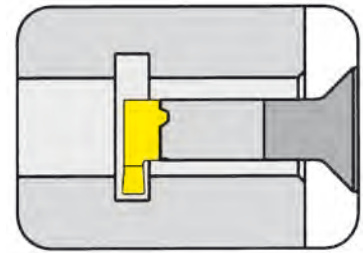

Bore Ø from	.630"
Depth of groove up to	.169"
Width of groove up to	.157"

Material of shank: Carbide - Giving a good vibration resistance

for use with Insert

Type 116
S116
U116

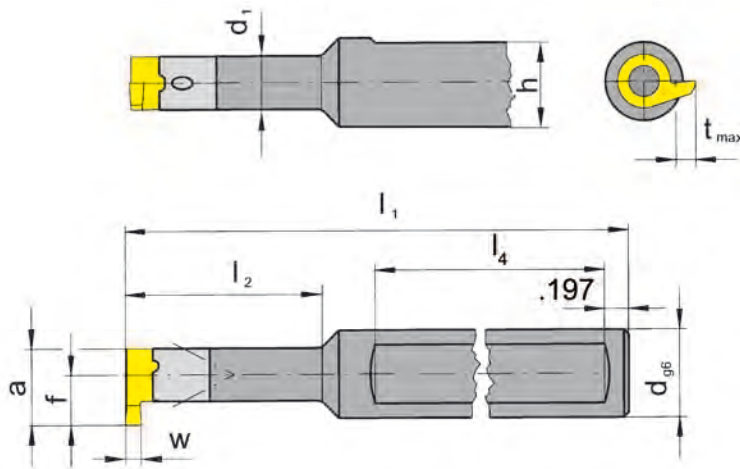

Picture = right hand cutting version shown

Part number	d	l ₁	l ₂	h	l ₄	d ₁	Remark
BU116.ST05.00	.500	3.150	.787	.460	1.770	.433	* Steel toolholder
BU116.0500.01		5.118	1.575				
BU116.0500.02	.500	5.118	2.205	.460	1.970	.433	
BU116.0500.03		5.906	3.150				
BU116.ST06.00	.625	3.150	.787	.585	1.770	.433	* Steel toolholder
BU116.0625.01		5.118	1.575				
BU116.0625.02	.625	5.118	2.205	.585	1.970	.433	
BU116.0625.03		5.906	3.150				

Further sizes upon request

w, a, t_{max} and f see inserts

Dimensions in inch

Note:

Toolholders can be used in right and left hand inserts.
Toolholders with damaged seating can be repaired by HORN.

* Steel toolholder is not repairable.

Spare parts

Toolholder	Screw	TORX PLUS® Wrench
BU116....	5.13T20EP	T20PQ

TOOLHOLDER Type

B116

with through coolant supply

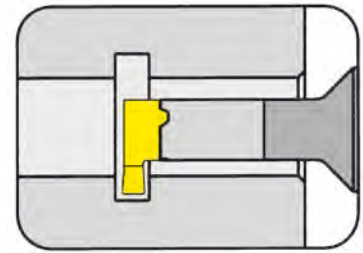

Bore Ø from	.630" (16.0 mm)
Depth of groove up to	.169" (4.3 mm)
Width of groove up to	.157" (4.0 mm)

Material of shank: Carbide - Giving a good vibration resistance

for use with Insert

Type 116
S116
U116

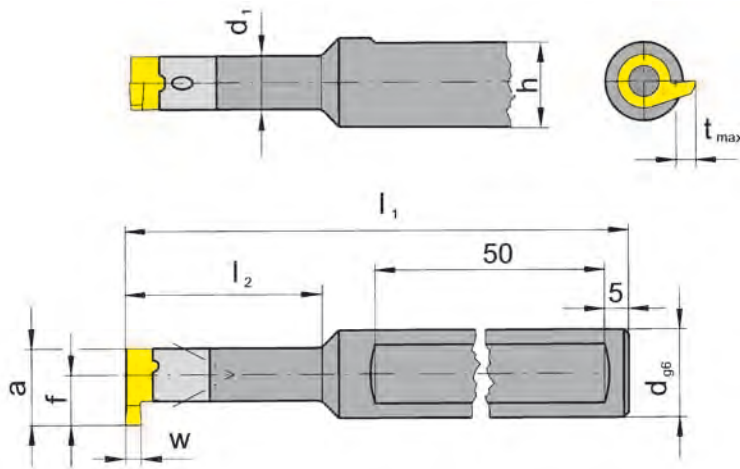

Picture = right hand cutting version shown

Part number	d	l ₁	l ₂	h	d ₁
B116.0012.01	12	130	40	11	11
B116.0012.02		130	56		
B116.0012.03		150	80		
B116.0016.01	16	130	40	15	11
B116.0016.02		130	56		
B116.0016.03		150	80		

Further sizes upon request

w, a, t_{max} and f see inserts

Dimensions in mm

Ordering note:

Toolholders can be used in right and left hand inserts.
Toolholders with damaged seating can be repaired by HORN.

Spare parts

Toolholder	Screw	TORX PLUS® Wrench
B116.001...	5.13T20EP	T20PQ

TOOLHOLDER Type

B116

with through coolant supply

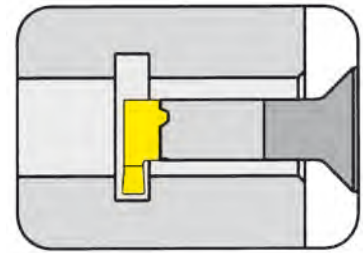

Bore Ø from	.630" (16.0 mm)
Depth of groove up to	.169" (4.3 mm)
Width of groove up to	.157" (4.0 mm)

Material of shank: Carbide - Giving a good vibration resistance

for use with Insert

Type 116
S116
U116

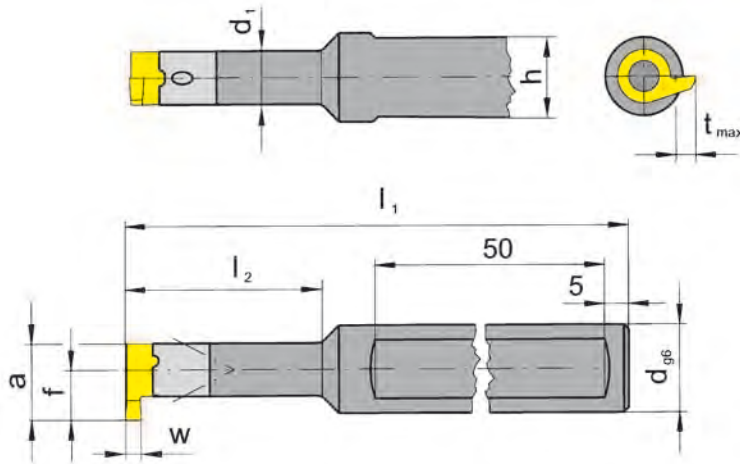

Picture = right hand cutting version shown

with 2 clamping flats

Part number	d	l ₁	l ₂	h	d ₁
B116.0012.2.01	12	130	40	11	
B116.0016.2.01	16	130	40	15	
B116.0012.2.02	12	130	56	11	11
B116.0016.2.02	16	130	56	15	
B116.0012.2.03	12	150	80	11	
B116.0016.2.03	16	150	80	15	11

Further sizes upon request

w, a, t_{max} and f see inserts

Dimensions in mm

Ordering note:

Toolholders can be used in right and left hand inserts.
Toolholders with damaged seating can be repaired by HORN.

Spare parts

Toolholder	Screw	TORX PLUS® Wrench
B116.001...	5.13T20EP	T20PQ

CARTRIDGE Type

145

for customized tools

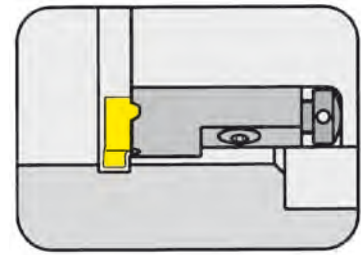

Bore Ø from	1.260" (32.0 mm)
Depth of groove up to	.169" (4.3 mm)
Width of groove up to	.157" (4.0 mm)

for use with Insert

Type 116
S116
U116

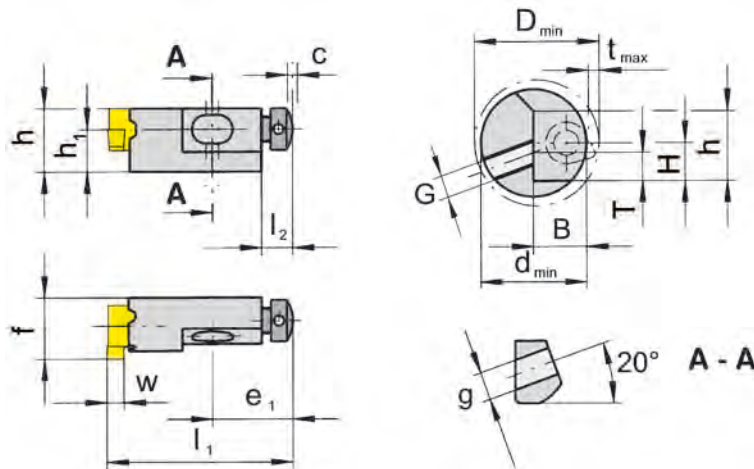

Part number	h_1	f	h	l_1	D_{min}	e_1	l_2	c	g	Clamping range
R/L145.1012.00	10	16.7	17	36	32	13.8	5	1	6.6	0.5 - 4.0

State R or L version

w and t_{max} see inserts

Dimensions in mm

Height of cutting edge h_1

Special height $h_1 = 6$ or 7 mm available upon request.

Seating sizes	H	T	B	G	d_{min}
R/L145.1012.00	10	9.0	12.0	M6	26

Spare parts

Cartridge	Screw	Screw	Adjust screw axial	TORX PLUS® Wrench
R/L145.1012.00	6.20.232	5.13T20EP	4.06.020	T20PQ



GROOVING (internal) $\geq \text{Ø} .630''$



INSERT Type

U116



Bore Ø from	.630"
Depth of groove up to	.047"
Width of groove	.031 - .039"

for use with Toolholder

Type 145
B116
BU116

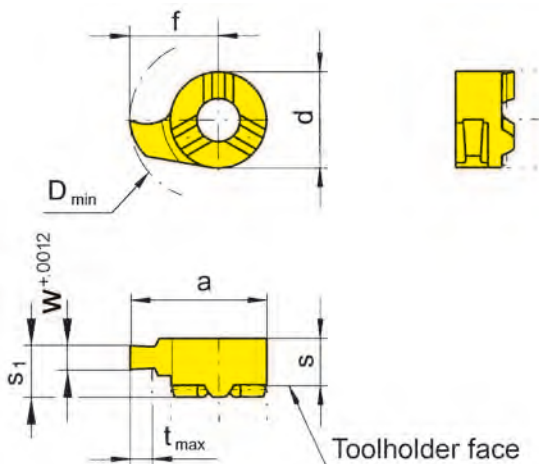

R = right hand version

L = left hand version

not face cutting,
limited depth of cut



Part number	w	s ₁	s	f	a	d	t _{max}	D _{min}	Carbide grades					
									MG12	TN35	TI25	TF45	TH35	
R/LU116.0031.00	.031							.630		▲/▲				
R/LU116.0039.00	.039	.209	.217	.402	.618	.433	.047			▲/▲				
									P	•				
									M	•				
									K	•				
									S	•				
									N	•				
									H					

- ▲ on stock Δ 4 weeks
- main recommendation
- o alternative recommendation
- uncoated grades
- coated grades
- brazed/Cermet

Dimensions in inch

State R or L version

GROOVING (internal) $\geq \text{Ø} .630''$



INSERT Type

116

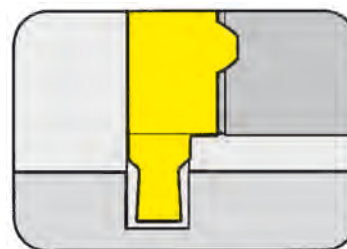

Bore Ø from	.630"
Depth of groove up to	.059"
Width of circlip Nw	.028 - .035"

Widths for circlip grooves DIN 471/472

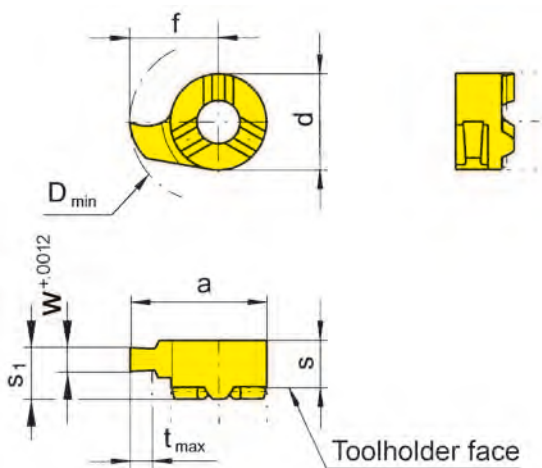

for use with Toolholder

Type 145
B116
BU116

not face cutting,
limited depth of cut

R = right hand version shown

L = left hand version

Part number	Nw	w	s ₁	s	f	a	d	t _{max}	D _{min}	Carbide grades				
										MG12	TN35	TI25	TF45	TH35
R/L116.0070.00	.028	.029						.047	.630		▲/▲			
R/L116.0080.00	.031	.033	.209	.217	.402	.618	.433	.051	.630		▲/▲			
R/L116.0090.00	.035	.037						.059	.630		▲/▲			
										P	•			
										M	•			
										K	•			
										S	•			
										N	•			
										H				

- ▲ on stock Δ 4 weeks
- main recommendation
- o alternative recommendation
- uncoated grades
- coated grades
- brazed/Cermet

Dimensions in inch

State R or L version



Carbide grades

NC-PROFILING (internal) $\geq \text{Ø} .630''$



INSERT Type

U116

Bore Ø from	.630"
Depth of groove up to	.169"
Width of groove	.031 - .125"

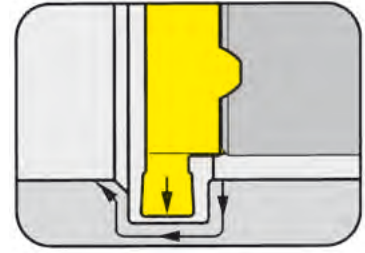

for use with Toolholder

Type 145
B116
BU116

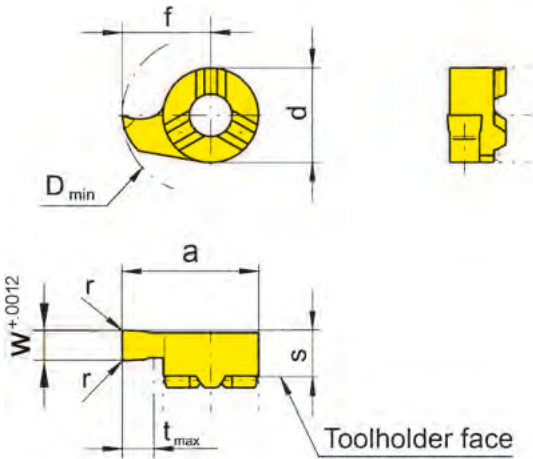

R = right hand version shown

L = left hand version

with corner radius

H

Part number	w	r	s	f	a	d	t _{max}	D _{min}		MG12	TN35	TI25	TF45	TH35
R/LU116.0031.08	.031									▲/	▲/▲			
R/LU116.0046.08	.046										▲/▲			
R/LU116.0062.08	.062										▲/▲	▲/	▲/	
R/LU116.0078.08	.078	.008	.209	.402	.618	.433	.169	.630		▲/	▲/▲			
R/LU116.0094.08	.094										▲/▲		▲/	
R/LU116.0125.08	.125										▲/▲			
										P	o	•	•	•
										M	•	•	•	•
										K	•	•	•	•
										S	•	•	•	•
										N	•	•	•	•
										H				

- ▲ on stock Δ 4 weeks
- main recommendation
- o alternative recommendation
- uncoated grades
- coated grades
- brazed/Cermet

Dimensions in inch

Carbide grades

State R or L version

H8

INSERT Type

116

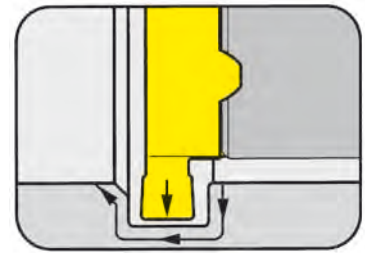

Bore \varnothing from	.630"
Depth of groove up to	.169"
Width of groove	.079"

for use with Toolholder

Type 145
B116
BU116

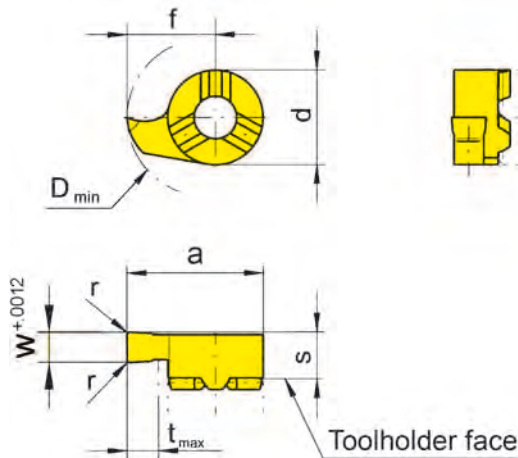

R = right hand version shown

L = left hand version

with corner radius

Part number	w	r	s	f	a	d	t _{max}	D _{min}	Carbide grades				
									MG12	TN35	TI25	TF45	TH35
R/L116.0200.02	.079	.008	.209	.402	.618	.433	.169	.630		▲/▲			▲/▲
▲ on stock Δ 4 weeks													
● main recommendation													
○ alternative recommendation													
□ uncoated grades													
■ coated grades													
■ brazed/Cermet													
P											●		●
M											●		●
K											●		●
S											●		●
N											●		●
H													

Dimensions in inch

State R or L version



GROOVING (internal) $\geq \text{Ø} .630''$



INSERT Type

U116

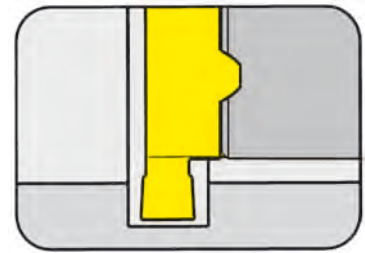

Bore Ø from	.630"
Depth of groove up to	.169"
Width of groove	.046 - .094"

for use with Toolholder

Type 145
B116
BU116

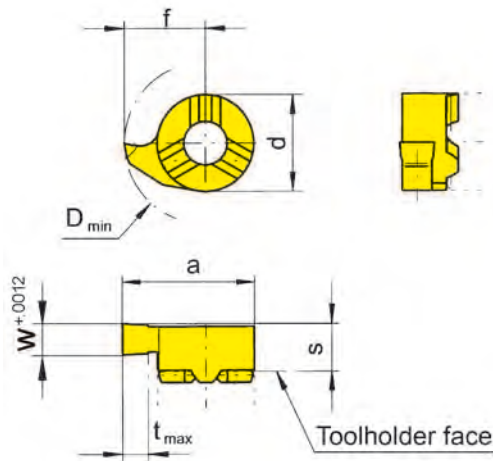

R = right hand version shown

L = left hand version

Part number	w	s	f	a	d	t _{max}	D _{min}	Carbide grades					
								MG12	TN35	TI25	TF45	TH35	
R/LU116.0046.00	.046								▲/▲				
R/LU116.0056.00	.056								▲/				
R/LU116.0062.00	.062	.209	.402	.618	.433	.169	.630	▲/	▲/▲		Δ/		
R/LU116.0078.00	.078								▲/▲				
R/LU116.0094.00	.094								▲/	▲/▲		Δ/	
▲ on stock Δ 4 weeks								P	o	•		•	
• main recommendation								M	•	•		•	
o alternative recommendation								K	•	•		•	
■ uncoated grades								S	•	•		•	
■ coated grades								N	•	•		•	
■ brazed/Cermet								H					

Dimensions in inch

State R or L version

Carbide grades

GROOVING (internal) $\geq \text{Ø} .630''$



INSERT Type

116

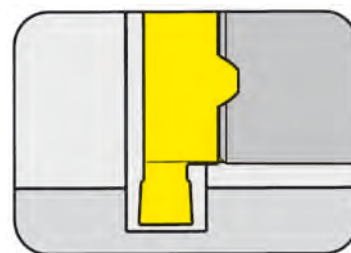

Bore Ø from	.630"
Depth of groove up to	.169"
Width of circlip Nw	.043 - .063"

Widths for circlip grooves DIN 471/472

for use with Toolholder

Type 145
B116
BU116

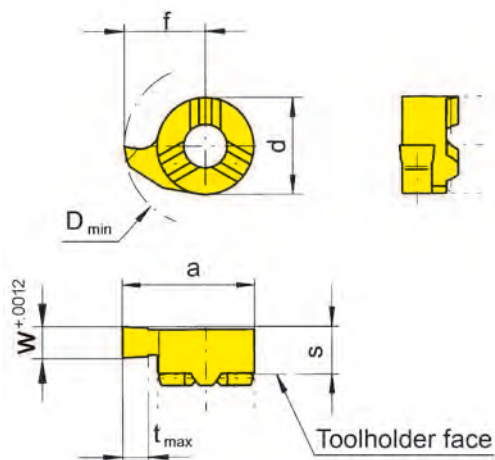

R = right hand version shown

L = left hand version

Part number	Nw	w	s	f	a	d	t _{max}	D _{min}	Carbide grades				
									MG12	TN35	TI25	TF45	TH35
R/L116.0110.00	.043	.047							▲/▲	▲/▲			▲/▲
R/L116.0130.00	.051	.055	.209	.402	.618	.433	.169	.630	▲/▲	▲/▲			▲/▲
R/L116.0160.00	.063	.067							▲/▲	▲/▲			▲/▲
									P	o	•		•
									M	•	•		•
									K	•	•		•
									S	•	•		•
									N	•	•		•
									H				

- ▲ on stock Δ 4 weeks
- main recommendation
- o alternative recommendation
- uncoated grades
- coated grades
- brazed/Cermet

Dimensions in inch

State R or L version

Carbide grades



GROOVING (internal) $\geq \text{Ø} .630''$



INSERT Type

116

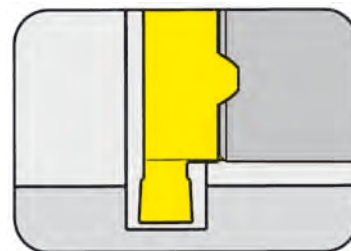

Bore Ø from	.630"
Depth of groove up to	.169"
Width of groove	.079 - .157"

for use with Toolholder

Type 145
B116
BU116

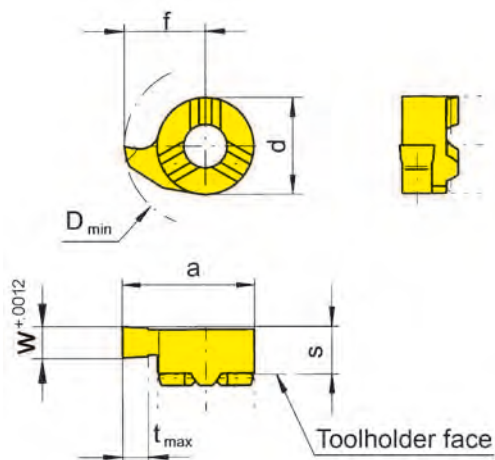

R = right hand version shown

L = left hand version

Part number	w	s	f	a	d	t _{max}	D _{min}	Carbide grades				
								MG12	TN35	TI25	TF45	TH35
R/L116.0200.00	.079							▲/▲	▲/▲			▲/▲
R/L116.0250.00	.098							▲/▲	▲/▲			▲/▲
R/L116.0300.00	.118	.209	.402	.618	.433	.169	.630	▲/▲	▲/▲			▲/▲
R/L116.0350.00	.138							▲/▲	▲/▲			▲/▲
R/L116.0400.00	.157							▲/▲	▲/▲			▲/▲
								P	o	•		•
								M	•	•		•
								K	•	•		•
								S	•	•		•
								N	•	•		•
								H				

- ▲ on stock Δ 4 weeks
- main recommendation
- o alternative recommendation
- uncoated grades
- coated grades
- brazed/Cermet

Dimensions in inch

State R or L version

Carbide grades

GROOVING (internal) $\geq \text{Ø} .630''$



INSERT Type

S116

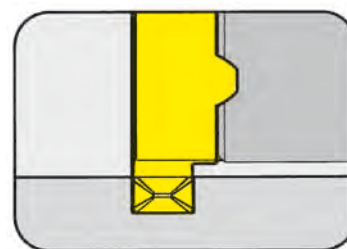

Bore Ø from	.630"
Depth of groove up to	.169"
Width of groove	.079 - .118"

for use with Toolholder

Type 145
B116
BU116

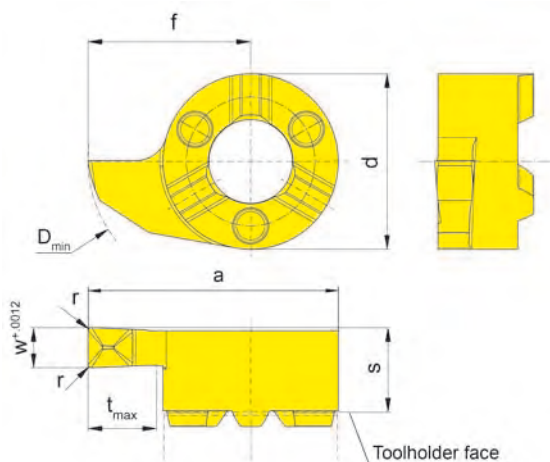

R = right hand version shown

L = left hand version

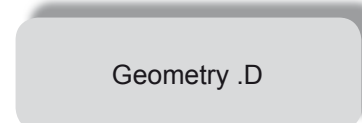

Part number	w	r	s	f	a	d	t _{max}	D _{min}	Carbide grades				
									MG12	TN35	TI25	TF45	TH35
R/LS116.0200.D2	.079												▲▲
R/LS116.0250.D2	.098	.008	.209	.402	.618	.433	.169	.630					▲▲
R/LS116.0300.D2	.118												▲▲
									P				•
									M				•
									K				•
									S				•
									N				•
									H				•



- ▲ on stock Δ 4 weeks
- main recommendation
- o alternative recommendation
- uncoated grades
- coated grades
- brazed/Cermet

Dimensions in inch

State R or L version

Carbide grades

GROOVING (internal) $\geq \text{Ø} .630''$



INSERT Type

U116

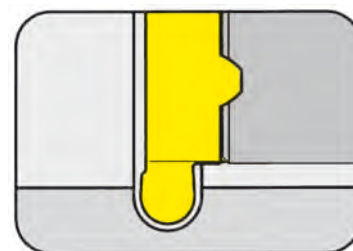

Bore Ø from	.630"
Depth of groove up to	.169"
Width of groove	.062 - .125"

for use with Toolholder

Type 145
B116
BU116

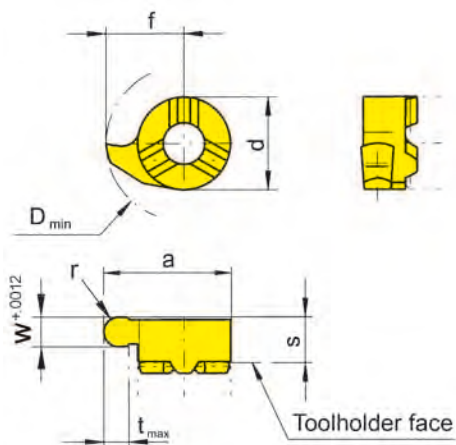

R = right hand version shown

L = left hand version

Full radius

Part number	w	r	s	f	a	d	t _{max}	D _{min}	Carbide grades					
									MG12	TN35	TI25	TF45	TH35	
R/LU116.0031.62	.062	.031								▲/▲				
R/LU116.0039.78	.078	.039								▲/▲				
R/LU116.0047.94	.094	.047	.209	.402	.618	.433	.169	.630		▲/▲				
R/LU116.0062.12	.125	.062								▲/▲				
										P	•			
										M	•			
										K	•			
										S	•			
										N	•			
										H				

- ▲ on stock Δ 4 weeks
- main recommendation
- o alternative recommendation
- uncoated grades
- coated grades
- brazed/Cermet

Dimensions in inch
State R or L version

Carbide grades

GROOVING (internal) $\geq \text{Ø} .630''$



INSERT Type

116

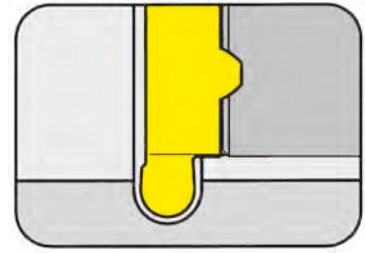

Bore Ø from	.630"
Depth of groove up to	.169"
Width of groove	.071 - .157"

for use with Toolholder

Type 145
B116
BU116

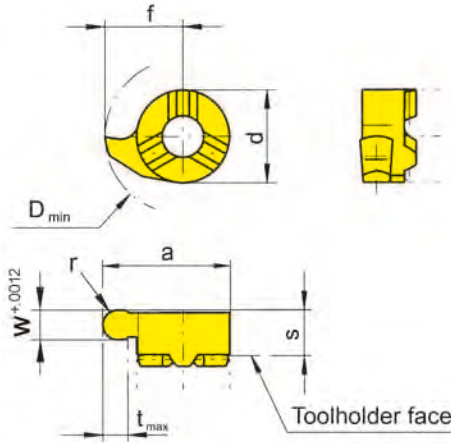

R = right hand version shown

L = left hand version

Full radius

Part number	w	r	s	f	a	d	t _{max}	D _{min}	Carbide grades				
									MG12	TN35	TI25	TF45	TH35
R/L116.0009.18	.071	.035							▲/△	▲/▲			▲/▲
R/L116.0011.22	.087	.043							▲/▲	▲/▲			▲/▲
R/L116.0015.30	.118	.043	.209	.402	.618	.433	.169	.630	▲/△	▲/▲			▲/▲
R/L116.0020.40	.157	.079							▲/▲	▲/▲			▲/▲
									P	o	•		•
									M	•	•		•
									K	•	•		•
									S	•	•		•
									N	•	•		•
									H				

- ▲ on stock △ 4 weeks
- main recommendation
- o alternative recommendation
- uncoated grades
- coated grades
- brazed/Cermet

Dimensions in inch

State R or L version

Carbide grades



INSERT Type

116

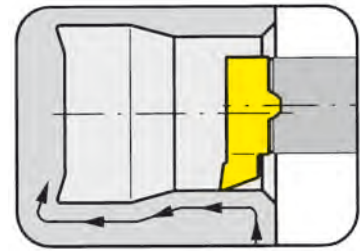

Bore Ø from .610''
 Depth of undercut up to .138''

for use with Toolholder

Type 145
 B116
 BU116

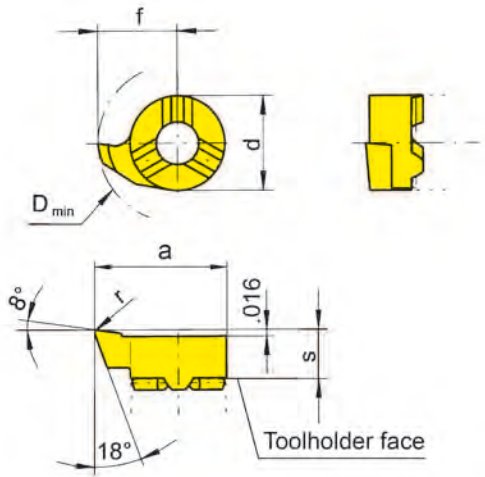

R = right hand version shown

L = left hand version

Part number	r	s	f	a	d	D _{min}	Carbide grades				
							MG12	TN35	TI25	TF45	TH35
R/L116.1897.02	.008	.209	.382	.598	.433	.610		▲/▲			▲/▲
▲ on stock Δ 4 weeks							P	•	•	•	•
● main recommendation							M	•	•	•	•
○ alternative recommendation							K	•	•	•	•
□ uncoated grades							S	•	•	•	•
■ coated grades							N	•	•	•	•
■ brazed/Cermet							H				

Dimensions in inch

State R or L version

The modified geometry allows boring of bores $\geq \text{Ø} .610''$ and profiling of reliefs as per DIN 509 form E and .

INSERT Type

S116

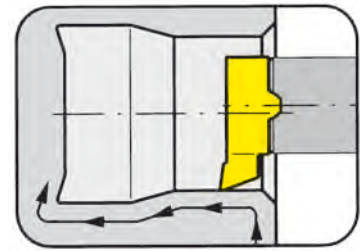

Bore Ø from .610"
 Depth of undercut up to .138"

for use with Toolholder

Type 145
 B116
 BU116

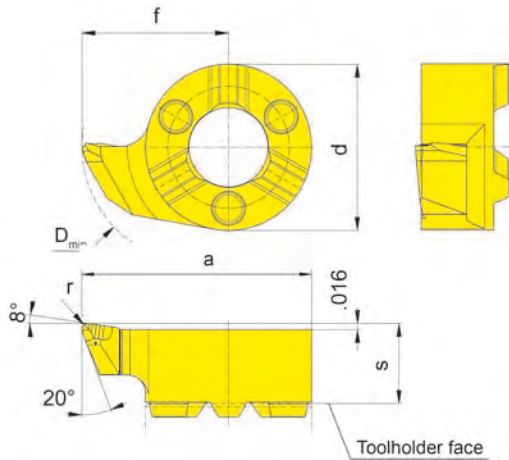

R = right hand version shown

L = left hand version

Geometry .R

Part number	r	s	f	a	d	D _{min}	Carbide grades				
							MG12	TN35	TI25	TF45	TH35
LS116.1897.R2	.008										▲
RS116.1897.R2	.008					.610					▲
LS116.1897.R4	.016	.209	.382	.598	.433	.610					▲
RS116.1897.R4	.016										▲
							P				●
							M				●
							K				●
							S				●
							N				●
							H				●



- ▲ on stock Δ 4 weeks
- main recommendation
- alternative recommendation
- uncoated grades
- coated grades
- brazed/Cermet

Dimensions in inch

State R or L version

The modified geometry allows boring of bores $\geq \text{Ø} .610''$ and profiling of reliefs as per DIN 509 form E and F.

INSERT Type

116

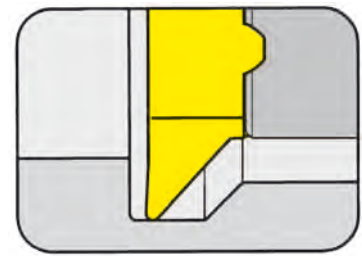

Bore Ø from .630''

for use with Toolholder

Type 145
B116
BU116

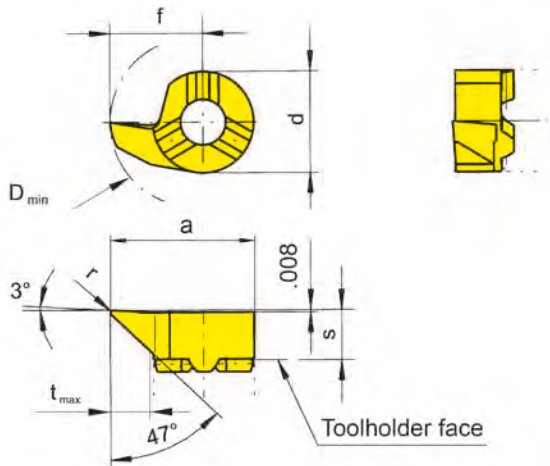

R = right hand version shown

L = left hand version

Part number	r	s	f	a	d	t _{max}	D _{min}	Carbide grades				
								MG12	TN35	TI25	TF45	TH35
R/L116.4702.02	.008	.209	.402	.618	.433	.169	.630		▲/▲			▲/▲
R/L116.4702.04	.016	.209	.402	.618	.433	.169	.630		▲/▲			▲/▲
								P	•	•	•	•
								M	•	•	•	•
								K	•	•	•	•
								S	•	•	•	•
								N	•	•	•	•
								H				

- ▲ on stock Δ 4 weeks
- main recommendation
- o alternative recommendation
- uncoated grades
- coated grades
- brazed/Cermet

Dimensions in inch

State R or L version

The modified geometry allows boring of bores $\geq \text{Ø} .630''$ and profiling of reliefs as per DIN 509 form

INSERT Type

116

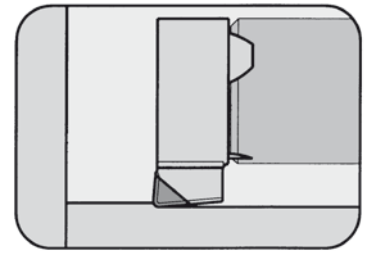

Bore Ø from .551"

for use with Toolholder

Type 145
B116
BU116

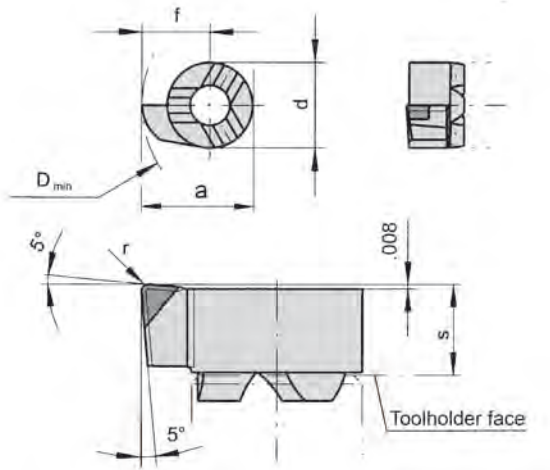

R = right hand version shown

CBN tipped

Part number	r	s	f	a	d	D _{min}		CB10
R116.0582.04.B	.016	.209	.323	.539	.433	.551		▲

- ▲ on stock Δ 4 weeks
- main recommendation
- alternative recommendation
- uncoated grades
- coated grades
- brazed/Cermet

P	▲
M	■
K	■
S	■
N	■
H	●

Dimensions in inch Carbide grades



INSERT Type

116

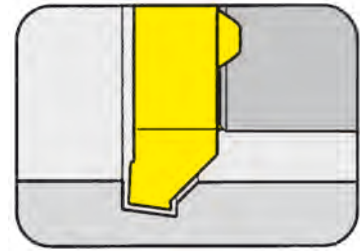

Bore Ø from .630"

for use with Toolholder

Type 145
B116
BU116

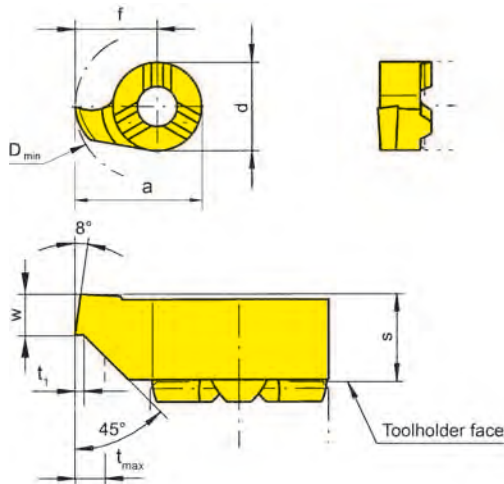

R = right hand version shown

L = left hand version

H

Part number	w	s	f	a	d	t ₁	t _{max}	D _{min}	Carbide grades				
									MG12	TN35	TI25	TF45	TH35
R/L116.0815.45	.059	.209	.402	.618	.433	.008	.059	.630	▲/▲		▲/▲		
▲ on stock Δ 4 weeks									P	○		●	
● main recommendation									M	●		●	
○ alternative recommendation									K	●		●	
■ uncoated grades									S	●		●	
■ coated grades									N	●		●	
■ brazed/Cermet									H				

Dimensions in inch

State R or L version

Reducing of tool change
from $\varnothing .709''$ (18 mm)

Pregrooving and Chamfering



Finishing

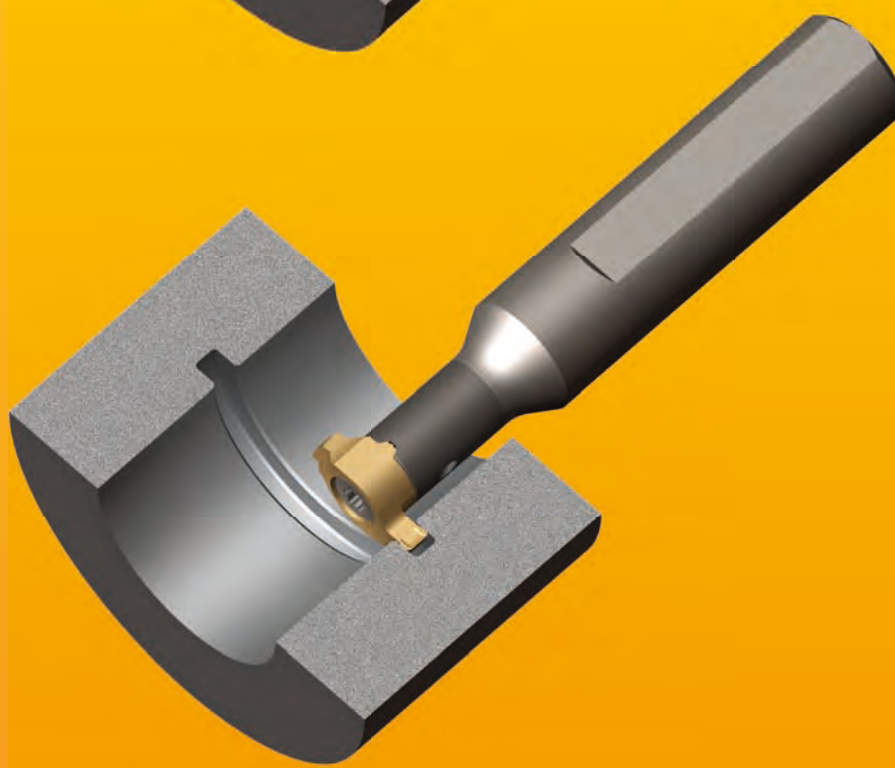

H

THREADING (internal) Partial profile



INSERT Type

116

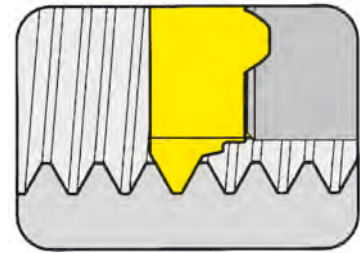

Bore Ø from Pitch .630" (16.0 mm)
2.0 - 2.5 mm

for use with Toolholder

Type 145
B116
BU116

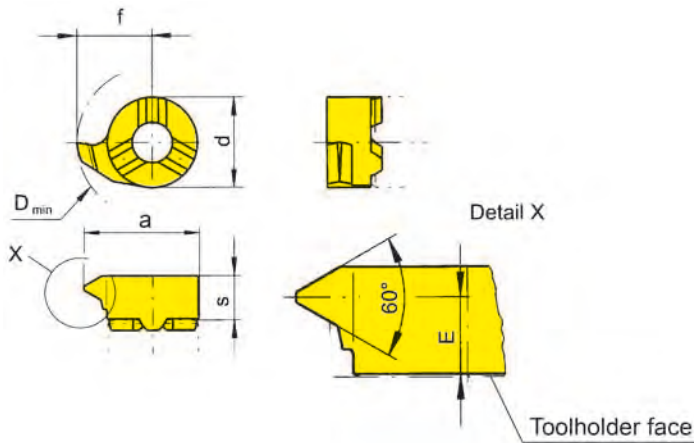

R = right hand version shown

L = left hand version

Metric ISO standard thread

Part number	P	E	s	f	a	d	D _{min}	Carbide grades				
								MG12	TN35	TI25	TF45	TH35
R/L116.1020.01	2.0	4.3	5.5	10.2	15.7	11	16		▲/▲			▲/▲
R/L116.1325.01	2.5	4.2	5.5	10.2	15.7	11	16		▲/▲			▲/▲
								P	•	•	•	•
								M	•	•	•	•
								K	•	•	•	•
								S	•	•	•	•
								N	•	•	•	•
								H	•	•	•	•

- ▲ on stock Δ 4 weeks
- main recommendation
- o alternative recommendation
- uncoated grades
- coated grades
- brazed/Cermet

Dimensions in mm

State R or L version

Carbide grades



THREADING (internal) Partial profile



INSERT Type

116

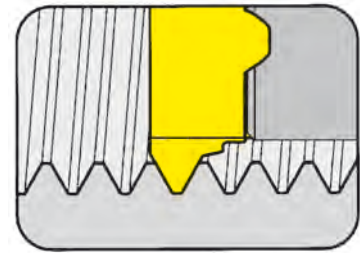

Bore Ø from Pitch .630" (16.0 mm)
1.0 - 1.5 mm

for use with Toolholder

Type 145
B116
BU116

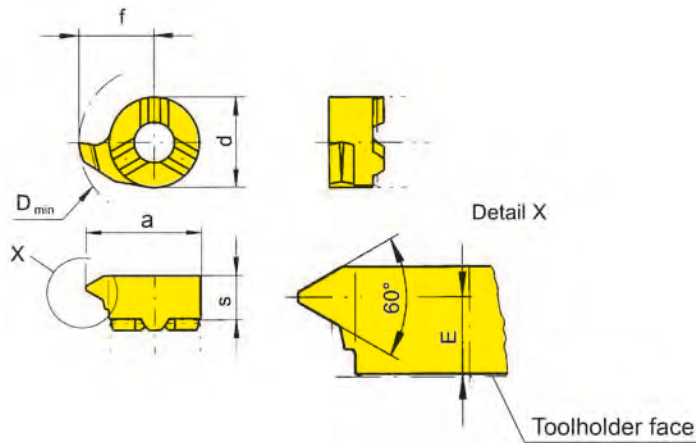

R = right hand version shown

L = left hand version

Metric ISO fine thread

Part number	P	P _{max}	E	s	f	a	d	D _{min}	Carbide grades				
									MG12	TN35	TI25	TF45	TH35
R/L116.0510.01	1.0	1.25	4.7	5.5	10.2	15.7	11	16		▲/▲			▲/▲
R/L116.0815.01	1.5	1.75	4.5	5.5	10.2	15.7	11	16		▲/▲			▲/▲
									P	•	•	•	•
									M	•	•	•	•
									K	•	•	•	•
									S	•	•	•	•
									N	•	•	•	•
									H	•	•	•	•

- ▲ on stock Δ 4 weeks
- main recommendation
- o alternative recommendation
- uncoated grades
- coated grades
- brazed/Cermet

Dimensions in mm

State R or L version



Carbide grades

THREADING (internal) Full profile



INSERT Type

116

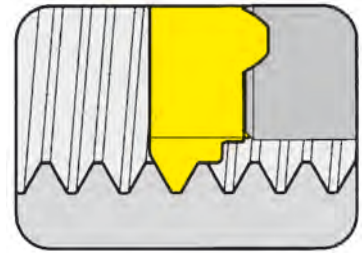

Bore Ø from Pitch .630" (16.0 mm)
2.5 - 4.0 mm

for use with Toolholder

Type 145
B116
BU116

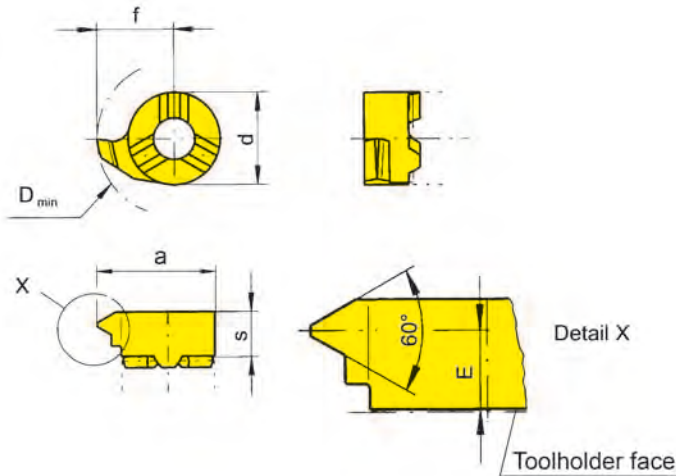

R = right hand version shown

L = left hand version

Metric ISO standard thread

Part number	P	E	s	f	a	d	D _{min}	Carbide grades						
								MG12	TN35	TI25	TF45	TH35		
R/L116.1325.02	2.5	4.2							▲/△					
R/L116.1630.02	3.0	4.0							▲/▲					
R/L116.1835.02	3.5	3.8	5.5	10.2	15.7	11	16		▲/▲					
R/L116.2140.02	4.0	3.6							▲/△					
									P	•				
									M	•				
									K	•				
									S	•				
									N	•				
									H					

- ▲ on stock △ 4 weeks
- main recommendation
- o alternative recommendation
- uncoated grades
- coated grades
- brazed/Cermet

Dimensions in mm
State R or L version

Carbide grades



THREADING (internal) Full profile



INSERT Type

116

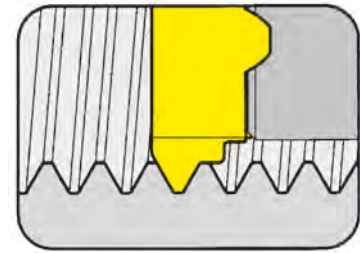

Bore Ø from Pitch .630" (16.0 mm)
1.0 - 2.0 mm

for use with Toolholder

Type 145
B116
BU116

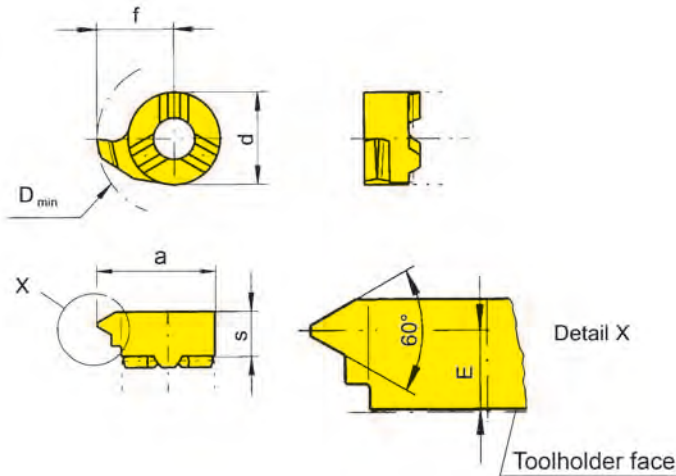

R = right hand version shown

L = left hand version

Metric ISO fine thread

Part number	P	E	s	f	a	d	D _{min}	Carbide grades						
								MG12	TN35	TI25	TF45	TH35		
R/L116.0510.02	1.0	4.7							▲/▲					
R/L116.0815.02	1.5	4.5	5.5	10.2	15.7	11	16		▲/▲					
R/L116.1020.02	2.0	4.3							▲/▲					
									●	●	●	●	●	●
									○	○	○	○	○	○
									■	■	■	■	■	■
									■	■	■	■	■	■
									■	■	■	■	■	■
									■	■	■	■	■	■

- ▲ on stock Δ 4 weeks
- main recommendation
- alternative recommendation
- uncoated grades
- coated grades
- brazed/Cermet

Dimensions in mm

State R or L version



THREADING (internal) Partial profile



INSERT Type

U116

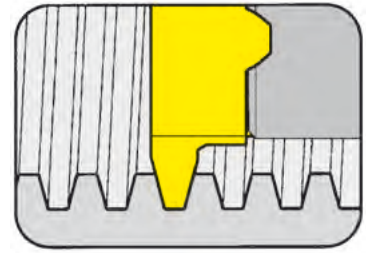

Bore Ø from Pitch .630"
3 - 6 tpi

for use with Toolholder

Type 145
B116
BU116

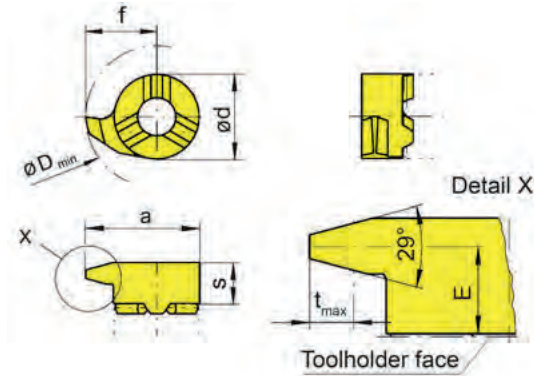

R = right hand version shown

L = left hand version

ACME / Stub ACME thread

Part number	Threads per Inch	E	s	f	a	d	D _{min}	MG12	TN35	Ti25	TF45	TH35
R/LU116.AC04.01	4	.131	.217	.382	.598	.433	.630		▲/▲			
R/LU116.AC05.01	5	.147	.217	.382	.598	.433	.630		▲/▲			
R/LU116.SA03.01	3	.150	.256	.402	.618				▲/			
R/LU116.SA04.01	4	.138	.217	.402	.618				▲/			
R/LU116.SA05.01	5	.150	.217	.402	.618	.433	.630		▲/▲			
R/LU116.SA06.01	6	.157	.217	.382	.598				▲/▲			
								P	•			
								M	•			
								K	•			
								S	•			
								N	•			
								H				

- ▲ on stock Δ 4 weeks
- main recommendation
- alternative recommendation
- uncoated grades
- coated grades
- brazed/Cermet

Dimensions in inch
State R or L version

Carbide grades

THREADING (internal) Partial profile



INSERT Type

116

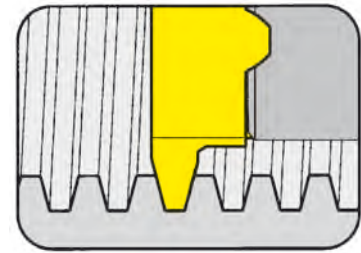

Bore Ø from Pitch .630" (16.0 mm)
2.0 - 6.0 mm

for use with Toolholder

Type 145
B116
BU116

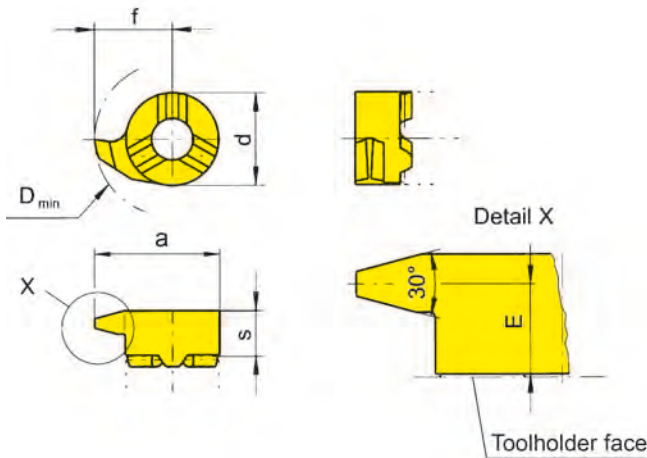

R = right hand version shown

L = left hand version

Metric ISO trapezoidal thread DIN 103

Part number	P	E	s	f	a	d	D _{min}	Carbide grades				
								MG12	TN35	TI25	TF45	TH35
R/L116.1220.01	2	4.50		9.7	15.2			▲/▲				
R/L116.1730.01	3	4.30		9.7	15.2			▲/▲				
R/L116.2240.01	4	4.00	5.5	9.7	15.2	11	16	▲/▲				
R/L116.2750.01	5	3.55		10.2	15.7			▲/▲				
R/L116.3560.01	6	3.30		10.2	15.7				▲/▲			
								P	•	•		
								M	•	•		
								K	•	•		
								S	•	•		
								N	•	•		
								H				

- ▲ on stock Δ 4 weeks
- main recommendation
- alternative recommendation
- uncoated grades
- coated grades
- brazed/Cermet

Dimensions in mm

State R or L version

Carbide grades



THREADING (internal) Full profile



INSERT Type

116

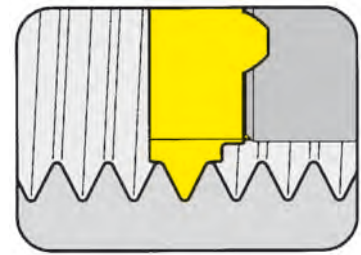

Bore Ø from	.630"
Threads per inch	11/14

for use with Toolholder

Type 145
B116
BU116

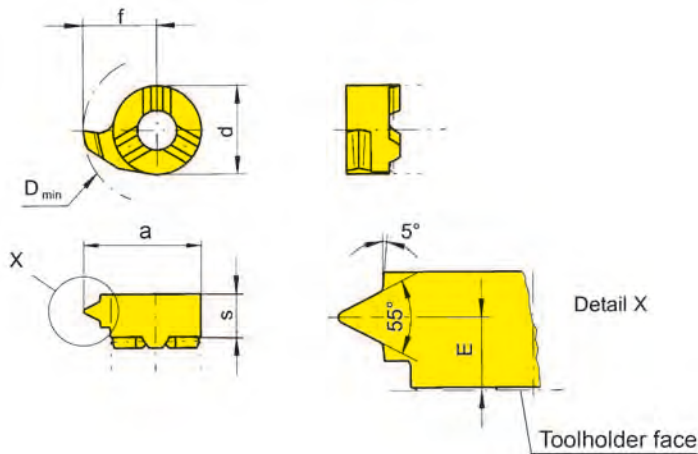

R = right hand version shown

L = left hand version

Whitworth pipe thread as per
DIN ISO 228; (259) and
2999

Part number	Threads per Inch	P	E	s	f	a	d	D _{min}	Carbide grades					
									MG12	TN35	TI25	TF45	TH35	
R/L116.5511.02	11	2.309	.138	.217	.402	.618	.433	.630		▲/▲				
R/L116.5514.02	14	1.814	.154	.217	.402	.618	.433	.630		▲/▲				
									P	•				
									M	•				
									K	•				
									S	•				
									N	•				
									H					

- ▲ on stock Δ 4 weeks
- main recommendation
- o alternative recommendation
- uncoated grades
- coated grades
- brazed/Cermet

Dimensions in inch

State R or L version

Carbide grades

HORN - THE LEADERS IN GROOVING TECHNOLOGY



ONE RESOURCE THAT WILL NEVER RUN DRY!

TOOLING SYSTEMS FOR THE OIL INDUSTRY: S117

- Extreme precision
- Optimal repeatability (≤ 0.005 mm)
- Extremely simple handling
- Patented reliability

HORN - INTELLIGENT TOOL DESIGN AT WORK.



For further information, please contact HORN USA.

HCG - HORN Catalog Guide

Bore Ø	Product line								
	105	110	108	10P	111	11P	114	116	18P
≥ .008" (0.2 mm)	•								
≥ .236" (6.0 mm)	•	•							
≥ .268" (6.8 mm)	•	•							
≥ .307" (7.8 mm)		•	•						
≥ .315" (8.0 mm)		•	•						
≥ .346" (8.8 mm)				•					
≥ .354" (9.0 mm)		•	•	•					
≥ .386" (9.8 mm)					•	•			
≥ .394" (10.0 mm)		•		•	•				
≥ .419" (10.5 mm)						•			
≥ .433" (11.0 mm)					•	•			
≥ .492" (12.5 mm)							•		
≥ .551" (14.0 mm)							•	•	
≥ .630" (16.0 mm)								•	
≥ .650" (16.5 mm)							•		
≥ .689" (17.5 mm)									•

Groove depth ≤ (inch)	.098"	.157"	.039"	.118"	.091"	.138"	.256"	.169"	.315"
Groove depth ≤ (mm)	2.5	4.0	1.0	3.0	2.3	3.5	6.5	4.3	8.0
Width of groove inch	.020"-.079"	.039"-.250"	.029"-.079"	.039"-.118"	.029"-.125"	.039"-.118"	.029"-.125"	.029"-.157"	.071"-.118"
Width of groove mm	0.5 - 2.0	1.0 - 6.35	0.74 - 2.0	1.0 - 3.0	0.74 - 3.18	1.0 - 3.0	0.74 - 3.18	0.74 - 4.0	1.8 - 3.0

Application	Product line								
	105	110	108	10P	111	11P	114	116	18P
Grooving	•	•	•	•	•	•	•	•	•
Boring	•	•	•	•	•	•	•	•	•
Threading	•		•		•		•	•	
Chamfering	•		•		•		•	•	
Face Grooving	•	•					•		
Hard turning	•		•		•		•	•	

Chapter	A	B	C	D	E	F	G	H	J
---------	----------	----------	----------	----------	----------	----------	----------	----------	----------

Special tools upon request

MINI CARBIDE GROOVING TOOLS

Toolholder
BU18P / B18P



Page J2-J3

Inserts
18P / S18P
≥ Ø .709" (18 mm)

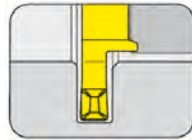

Page J4, J6

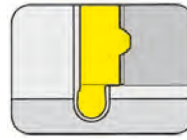

Page J5

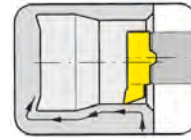

Page J7

Technical Instructions

Page L1 - L9

J

TOOLHOLDER Type

BU18P

with through coolant supply

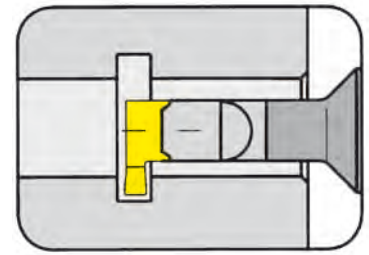

Bore Ø from	.709"
Depth of groove up to	.315"
Width of groove up to	.118"

Material of shank: Carbide - Giving a good vibration resistance

for use with Insert

Type 18P
S18P

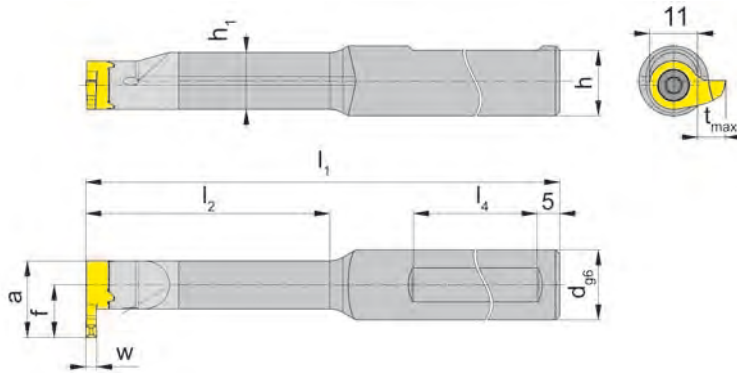

R = right hand version shown

L = left hand version

Part number	d	l ₁	l ₂	h	h ₁	l ₄
R/LBU18P.0500.00	.500	3.937	.984	.461	.500	1.969
R/LBU18P.0500.01		4.724	1.575			
R/LBU18P.0625.00	.625	3.937	.984	.585	.512	1.969
R/LBU18P.0625.01		4.724	1.575			
R/LBU18P.0625.02		5.118	2.205			
R/LBU18P.0625.03		5.906	3.150			

State R or L version

w, a, t_{max} and f see inserts

Dimensions in inch

Further sizes upon request

Ordering note:

Toolholders with damaged seating can be repaired by HORN.

Spare parts

Toolholder	Screw	TORX PLUS® Wrench
R/LBU18P.0...	5.13T20EP	T20PQ

TOOLHOLDER Type

B18P

with through coolant supply

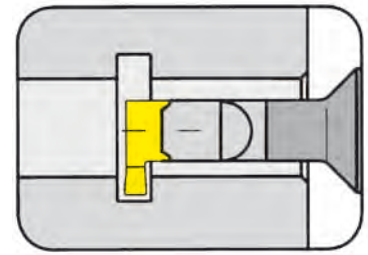

Bore Ø from	.709" (18.0 mm)
Depth of groove up to	.315" (8.0 mm)
Width of groove up to	.118" (3.0 mm)

Material of shank: Carbide - Giving a good vibration resistance

for use with Insert

Type 18P
S18P

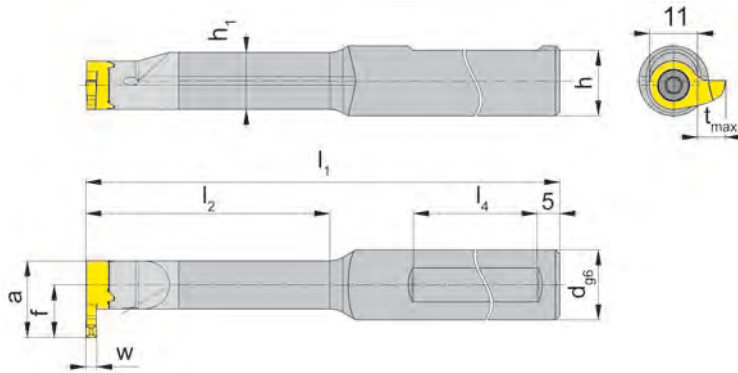

R = right hand version shown

L = left hand version

Part number	d	l ₁	l ₂	h	h ₁	l ₄
R/LB18P.0012.00 R/LB18P.0012.01	12	100 120	25 40	11	12.5	50
R/LB18P.0016.00 R/LB18P.0016.01 R/LB18P.0016.02 R/LB18P.0016.03	16	100 120 130 150	25 40 56 80	15	13.0	50

State R or L version

w, a, t_{max} and f see inserts

Dimensions in mm

Further sizes upon request

Ordering note:

Toolholders with damaged seating can be repaired by HORN.

Spare parts

Toolholder	Screw	TORX PLUS® Wrench
R/LB18P.001...	5.13T20EP	T20PQ



GROOVING (internal) $\geq \text{Ø} .709''$



INSERT Type

S18P

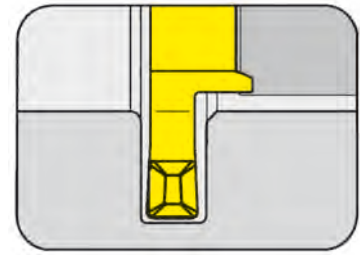

for use with Toolholder

Type B18P
BU18P

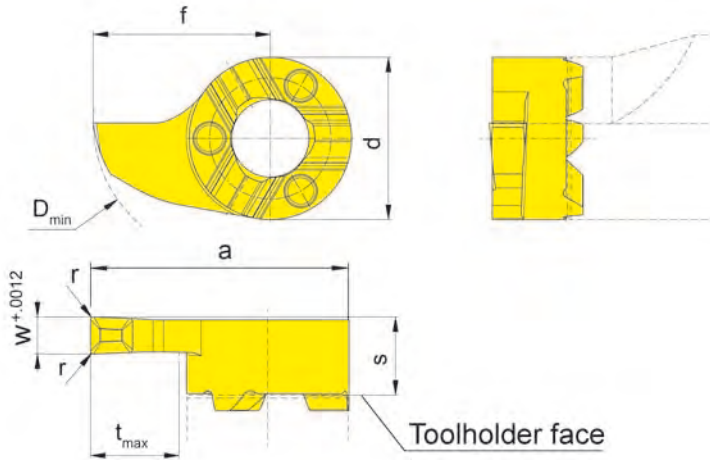

R = right hand version shown

L = left hand version

Part number	w	r	s	f	a	d	t _{max}	D _{min}	Carbide grades				
									MG12	TN35	TI25	TH35	
R/LS18P.0200.1.D2	.079											▲▲	●
R/LS18P.0250.1.D2	.098	.008	.209	.472	.689	.433	.236	.709				▲▲	●
R/LS18P.0300.1.D2	.118											▲▲	●
										P			●
										M			●
										K			●
										S			●
										N			●
										H			●

- ▲ on stock Δ 4 weeks
- main recommendation
- alternative recommendation
- uncoated grades
- coated grades
- brazed/Cermet

Dimensions in inch

State R or L version

Carbide grades

GROOVING (internal) $\geq \text{Ø} .709''$



INSERT Type

18P

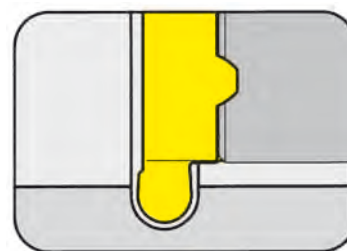

Bore Ø from	.709"
Depth of groove up to	.236"
Width of groove	.071 - .118"

for use with Toolholder

Type B18P
BU18P

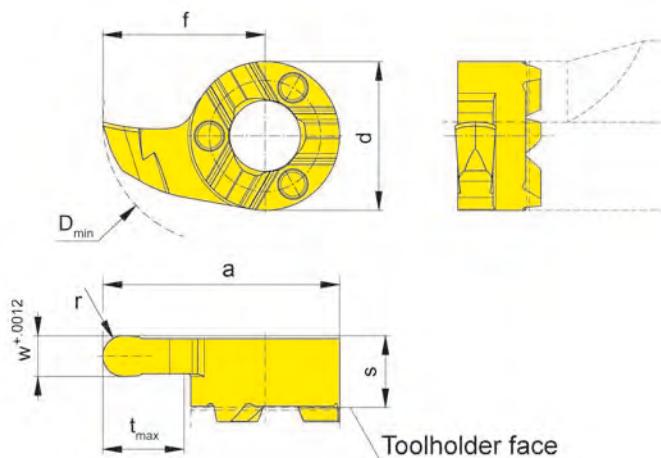

R = right hand version shown

L = left hand version

Full radius

Part number	w	r	s	f	a	d	t _{max}	D _{min}	Carbide grades			
									MG12	TN35	TI25	TH35
R/L18P.0009.1.18	.071	.035										▲▲
R/L18P.0011.1.22	.087	.043	.209	.472	.689	.433	.236	.709				▲▲
R/L18P.0015.1.30	.118	.059										▲▲
									P			•
									M			•
									K			•
									S			•
									N			•
									H			•

- ▲ on stock Δ 4 weeks
- main recommendation
- o alternative recommendation
- uncoated grades
- coated grades
- brazed/Cermet

Dimensions in inch

State R or L version

Carbide grades



GROOVING (internal) $\geq \text{Ø} .787''$



INSERT Type

S18P

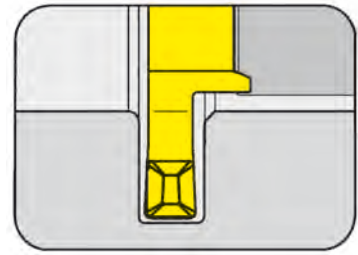

for use with Toolholder

Type B18P
BU18P

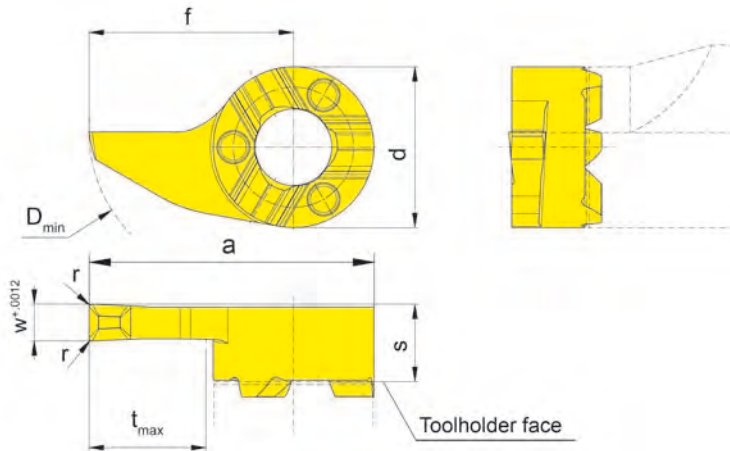

R = right hand version shown

L = left hand version

Part number	w	r	s	f	a	d	t _{max}	D _{min}	Carbide grades			
									MG12	TN35	TI25	TH35
R/LS18P.0200.2.D2	.079											▲▲
R/LS18P.0250.2.D2	.098	.008	.209	.551	.768	.433	.315	.787				▲▲
R/LS18P.0300.2.D2	.118											▲▲
										P		•
										M		•
										K		•
										S		•
										N		•
										H		•

- ▲ on stock Δ 4 weeks
- main recommendation
- o alternative recommendation
- uncoated grades
- coated grades
- brazed/Cermet

Dimensions in inch

State R or L version

Carbide grades

INSERT Type

S18P

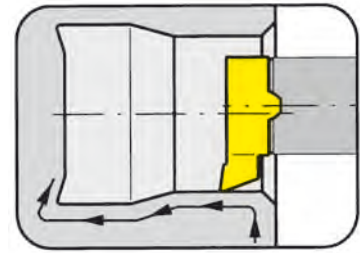

Bore Ø from .689"
 Depth of undercut up to .217"

for use with Toolholder

Type B18P
 BU18P

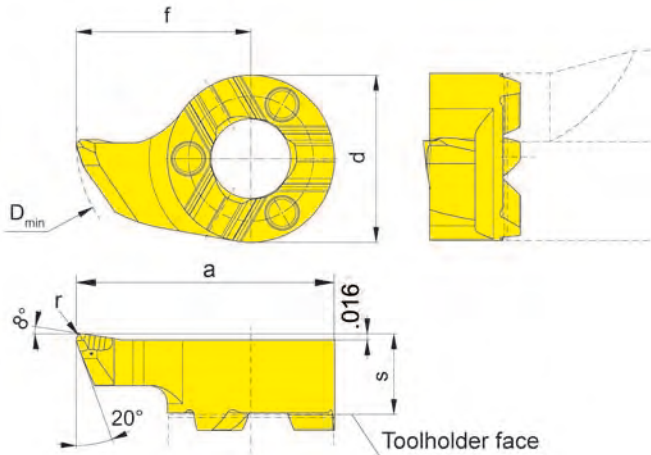

R = right hand version shown

L = left hand version

Part number	r	s	f	a	d	D _{min}	Carbide grades			
							MG12	TN35	Ti25	TH35
LS18P.1815.R2	.008									▲
RS18P.1815.R2	.008					.689				▲
LS18P.1815.R4	.016	.209	.453	.669	.433					▲
RS18P.1815.R4	.016									▲
							P			•
							M			•
							K			•
							S			•
							N			•
							H			•

- ▲ on stock Δ 4 weeks
- main recommendation
- o alternative recommendation
- uncoated grades
- coated grades
- brazed/Cermet

Dimensions in inch

State R or L version

The modified geometry allows boring of bores $\geq \text{Ø} .689''$ and profiling of reliefs as per DIN 509 form E and .





J

- short tool changing times
- high precision guaranteed for smooth cutting
- very good surface finish on the threads
- high tool life per edge due to even cutting action

For further information, please contact HORN USA.

Supermini®

Mini

Examples for machining

K

Technical Instructions, Additional equipment

L

Insert Type 105

Deburring cross holes using a rotating insert with a full radius

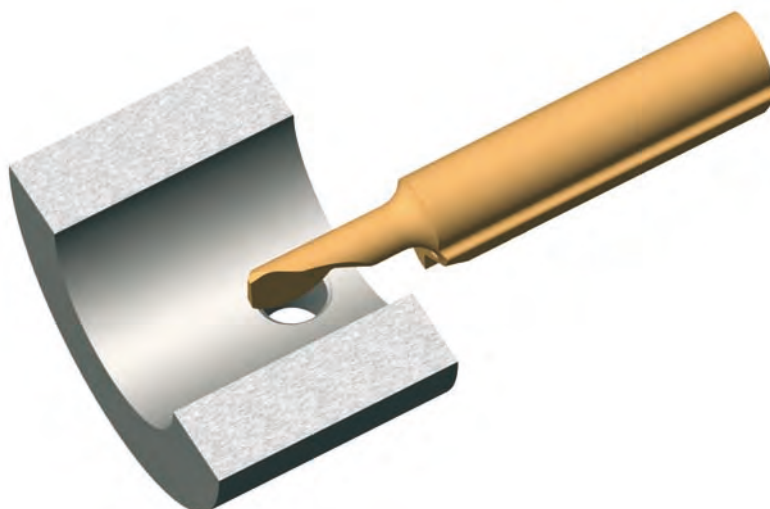

Insert Type 105

Profiling a face groove (full radius insert)

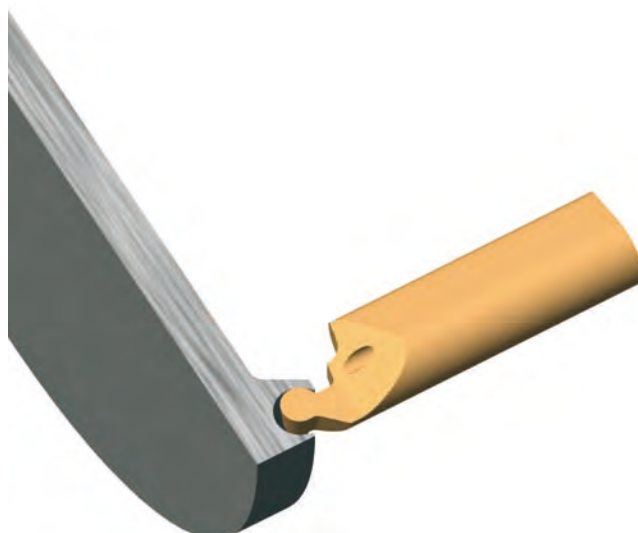

K

Insert Type 105

Machining a hemisphere

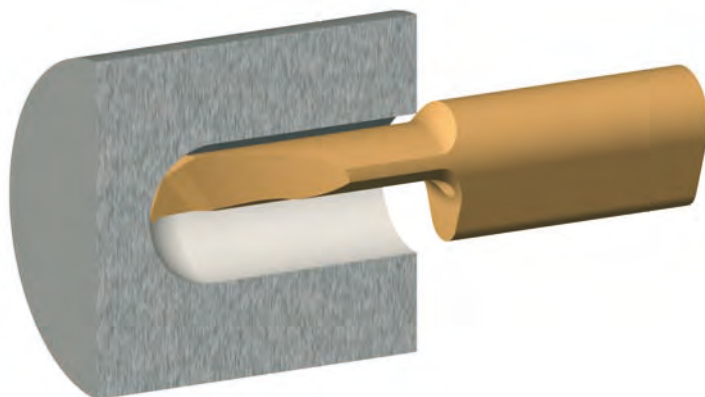

Insert Type 105

Face grooving with chamfers

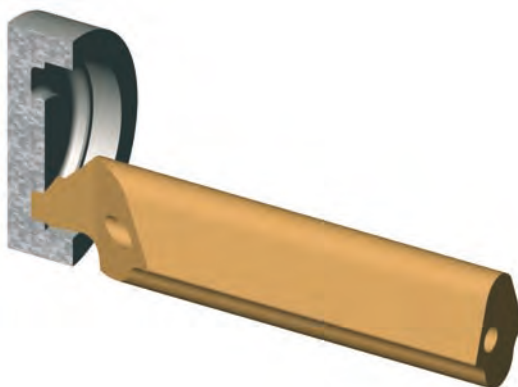

K

Insert Type 105

Machining a flat bottom hole with an undercut

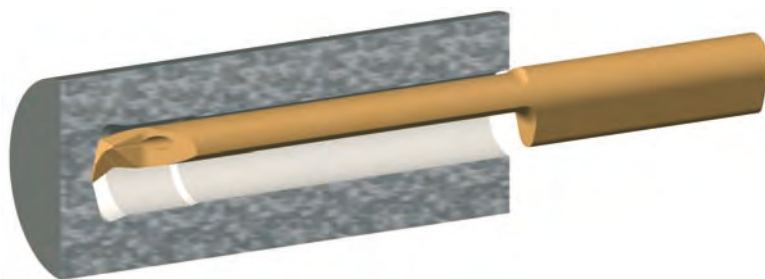

Insert Type 105

Machining of a dovetail face groove

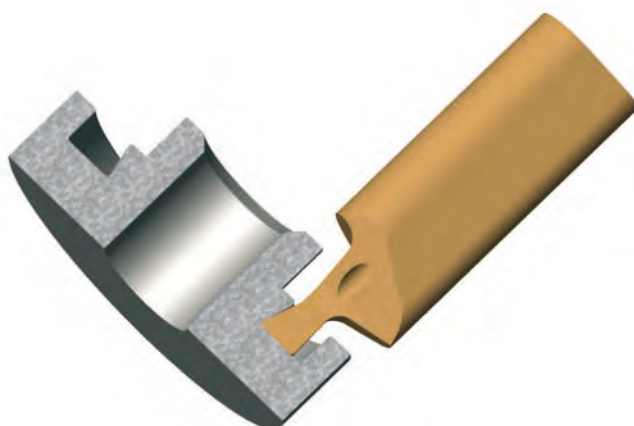

K

Insert Type 105

Plunge machining of a convexed face
in a bore

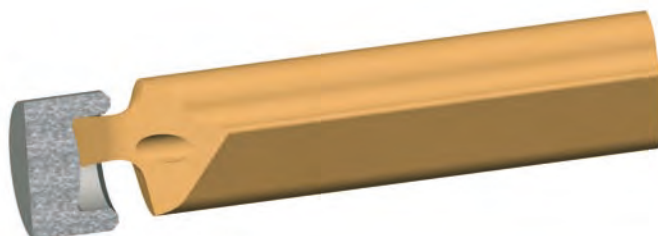

Insert Type 105

Profiling of deep bore

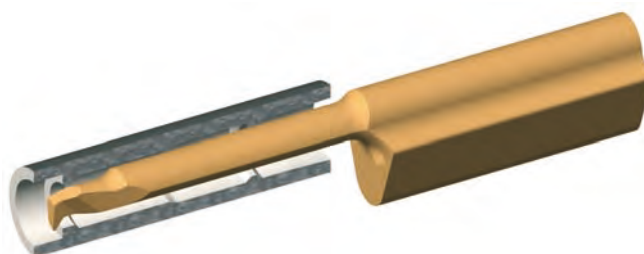

K

RECOMMENDED NUMBER OF PASSES

Carbide grade	Steel (thousands of lb/in ² Tensile strength)					Stainless steel	Cast iron	Aluminum	
	58-72	72-101	101-123	123-167	> 167				
TN35	58-72	72-101	101-123	123-167	> 167	300	330	980	
V _{max} feet/min	525	460	390	300	230	300	330	980	
Pitch		Number of passes							
mm	tpi								
0,8	32	8	8	9	9	10	10	9	8
1,0	24	10	10	12	12	12	12	12	10
1,25	20-19	12	12	14	14	15	15	14	12
1,5	16	15	15	17	17	18	18	17	15
1,75	14	17	17	19	19	21	21	18	17
2,0	12-11	19	20	22	22	25	25	20	18
2,5	10	22	24	26	26	31	31	22	20
3,0-3,5	8	28	30	32	32	38	38	24	22

FEED RATE internal threading

Right hand thread

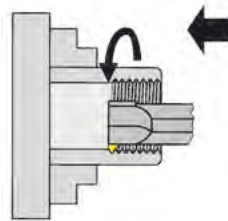

Toolholder right hand

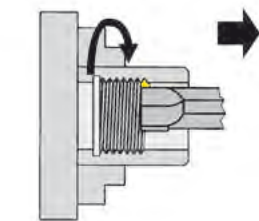

Toolholder left hand

Left hand thread

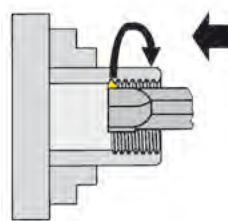

Toolholder left hand

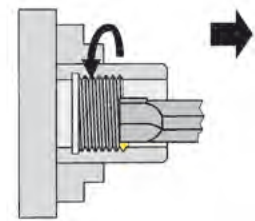

Toolholder right hand

IN-FEED

RADIAL IN-FEED

Metal removed on both sides of the insert simultaneously. The most commonly used method for thread production.



MODIFIED FLANK IN-FEED

Less wear of the trailing edge and better surface finish on corresponding flank.



ALTERNATING FLANK IN-FEED

Both edges are being fully utilised which means longer insert life.



FLANK IN-FEED

More easily formed chip and better heat dissipation.



THREADING

All threads up to 4,5 ° helix angle can be manufactured with HORN standard threading inserts. No special anvils will be necessary.

SEATINGS

The seating design of tooling type MINI as well as Supermini® guarantee the accurate center height of these tools. In spite of this, always check center height because a difference may cause problems, especially when machining small diameters.

TORQUE OF SCREWS

The following torque specifications are required for screws of MINI inserts. We do not recommend the use of anti-seize pastes.

Screw	T8(Type108)	T8(Type10P)	T9(Type11P)	T10(Type111)	T15(Type114)	T20(Type116)
Torque lbf-in.	9 - 13	9 - 13	13 - 18	22 - 26	35 - 40	50 - 55

REMOVAL OF CHIPS

Please choose inserts with smaller cutting widths, which helps aid chip evacuation and flow out of the bore.

To avoid chip packing, use proper machining techniques, such as grooving by steps.

COOLANT

Use a filtered coolant for transporting the chips out and for cooling the insert itself. A coolant pressure of 5 bar min. is recommended.

CUTTING DATA



Nominal cutting speeds with HORN grades

ISO	Material	Hardness Brinell	Feed rate IPR							
			Supermini®			Mini				
				.0004"-.0008"		.0004"-.0012"				
				.0008"-.002"		.0012"-.004"				
				.0008"-.002"		.0004"-.003"				
			Cutting speed *v _c ft/m							
			MG12	TN35	TI25	TF45	TH35	CB10/50		
P	Carbon steel	C < 0,4%	125							
		C > 0,4% < 0,6 %	150	46-361	46-590	46-590	46-590	46-590		
		C > 0,4% < 0,6 %	200							
	low alloyed steel	annealed	180							
		quenched	275	53-295	53-492	53-492		53-590		
		quenched	300							
	high alloyed steel	annealed	200							
		quenched	325		63-295	63-295		63-400		
	Cast steel	unalloyed	180							
		low alloyed	220	63-361	63-590	63-590		63-590		
high alloyed		225								
M	Stainless steel	martensitic, ferritic	200		63-295	63-295		63-295		
		austenitic	180		53-263			53-263		
K	Cast iron		180-260	53-295	53-492	53-492	53-492	53-492		
	Spheroidal graphite cast iron		180-260	53-295	53-425	53-425	53-492	53-492		
	Malleable cast iron		130-230		53-425	53-425	53-492	53-492		
S	Heat resistant alloy	NiFe				59-246	59-246	59-246		
		NiCo				59-131	59-131	59-131		
N	Al-alloy			46-722	53-1970	53-1970		53-1970		
	Copper and brass alloys			46-722	46-2300	46-2300		46-2300		
H	hardened material	> 54 HRC							65-455	

V_c is depending on the tool diameter and therefore of the maximum numbers of revolutions of the machine.

UNCOATED GRADES

MG12 - a universal grade with good wear resistance. Used at low or medium cutting speeds for machining steel, cast iron and non ferrous materials

COATED GRADES

TN35 - a very popular grade TiN coated used to low or medium cutting speeds. Also recommended for machining stainless steel or exotic alloyed materials

TI25 - a TiCN coated grade with high abrasion resistance. Recommended for machining steel and non ferrous materials at medium cutting speeds

TF45 - a TiAlN coated grade. This coating has a very high temperature stability and high hardness and is only used for special applications.

TH35 - new standard grade - extreme temperature stability with high hardness and very good coefficient of friction



D 15 VL

Model 1-5 Nm

Torque screw driver with scale
- variable torque setting
- adjusted torque is shown on display

The Torque can be adjusted with a special torque setter (id.)
Ergonomical form gives perfect handling abilities. Acoustic signal when setted torque is reached.
(Standard: EN ISO 6798, BS EN 26789, ASME B 107.14.M.)
(Precision: $\pm 6 \%$)



D 28 VL

Model 2-8 Nm



ED 28 VL

Torque setter

Device for setting the required torque.

Handle: Celluloseacetat with micro structured surface

Blade: Octogonal (8 flats) blade, hardened galvaniz d

L

ADDITIONAL EQUIPMENT



Universal Bitholder with T-handle
For S.DM08, S.DM10 and S.DM12
also for all C6,3 and E6,3 (1/4") Bits

Blade: High quality Chrome-Vanadium steel, through hardened, chrome plated.
Collar: Stainless steel
Utilization: For controlled opening

14ZQK



Blade for TORX-Plus® screws

Blade: High quality Chrome-Vanadium steel, through hardened, chrome plated.
Wiha Chrome Blade guarantees maximum precision.
Colored code green
Utilization: For controlled screw setting with definite torque in combination with Wiha torque screw driver handle.

DT8PK
DT10PK
DT15PK
DT20PK
DT25PK



Universal Bitholder
For S.DM08, S.DM10 and S.DM12 also
for all C6,3 and E6,3 (1/4") Bits

Blade: High quality Chrome-Vanadium steel, through hardened, chrome plated.
Collar: Stainless steel
Utilization: For controlled screw setting with definite torque in combination with torque screw driver handle.

D14ZBK

L



Torque screw driver with scale
 - variable torque setting
 - adjusted torque is shown on display

The Torque can be adjusted with a special torque setter (id.)
 Ergonomical form gives perfect handling abilities. Acoustic signal when setted torque is reached.
 (Standard: EN ISO 6798, BS EN 26789, ASME B 107.14.M.)
 (Precision: ± 6 %)

D515QL

Model 5-15 Nm



Torque setter

Device for setting the required torque.

Handle: Celluloseacetat with micro structured surface

Blade: Octogonal (8 flats) blade, hardened galvaniz d

ED515QL



Universal Bitholder

For S.DM08, S.DM10 and S.DM12 also
 for all C6,3 and E6,3 (1/4") Bits

Blade: High quality Chrome-Vanadium steel, through hardened, chrome plated.

Collar: Stainless steel

Utilization: For controlled screw setting with definite torque in combination with torque screw driver handle.

D14ZBQ





Blade for TORX-Plus® screws

Blade: High quality Chrome-Vanadium steel, through hardened, chrome plated.
Wiha Chrome Blade guarantees maximum precision.
Colored code green

Utilization: For controlled screw setting with definite torque in combination with Wiha torque screw driver handle.

DT15Q
DT20Q
DT25Q
DT30Q



Wrench for TORX PLUS® Screws

Utilization: For all kind of using TORX PLUS® Screws

Attention: TORX PLUS®-Wrench does NOT fit for Torx-Screws

T6PW
T7PW
T8PW
T9PW
T10PW
T15PW
T20PW
T25PW
T30PW

L

Type	Page
105	A56-A78,A80,A82,A84,A90,A92-A101, A104-A106,A109-A111,A119
108	C9,C11,C13-C14,C17-C18,C20-C21,C23-C29
10P	D6,D8
110	B10-B13
111	E9,E11,E13-E14,E17-E18,E20-E21,E23- E29,E31-E32
114	G9,G11,G13-G14,G17,G21-G22,G24- G32,G35,G37,G39,G41
116	H7,H9,H11-H12,H15-H16,H18-H20,H22- H25,H27-H28
11P	F6,F8,F10
125	E7
145	H5
18P	J5
962	A22-A23
963	A24
A105	A114
A110	B24-B25
AIH	A25
B105	A5-A11,A13-A14,A33,A113
B105...02	A117
B105C	A47-A48,A118
B105KM	A52-A55
B108	C3-C5
B108KM	C6-C7
B10P	D3-D5
B110	B3-B4,B23
B110C	B5-B6
B110KM	B7
B111	E3-E6
B114	G3-G5
B116	H3-H4
B11P	F3-F5
B18P	J3
BGT	A28,A30-A31
BKT	A29,A32

Type	Page
BU105	A4,A6,A12,A112 A116
BU108	C2
BU10P	D2
BU110	B2,B22
BU111	E2
BU114	G2
BU116	H2
BU11P	F2
BU18P	J2
G	A34-A35
H105	A20
HC105	A18-A19
HC114	G7
HCU114	G6
HVR40	A39
IR105	A16-A17
KM16	A50-A51
N	A38,A40-A43,B9
S108	C15,C19
S10P	D7,D9-D10
S111	E15,E19
S114	G15,G18,G23
S116	H13,H17
S11P	F7,F9,F11
S18P	J4,J6-J7
U105	A79,A81,A83,A85-A89,A91,A102-A103, A107-A108
U108	C8,C10,C12,C16
U110	B14-B18,B20-B21
U111	E8,E10,E12,E16,E30
U114	G8,G10,G12,G16,G20,G34,G36,G38,G40
U116	H6,H8,H10,H14,H26
VDI	A46,B8
Z	A36-A37

Cutting Material Group per DIN ISO 513

Main Group	Symbol	Subgroups
Carbide	HW	uncoated carbides based upon WC
	HT	uncoated carbides based upon TIC/TIN (cermets)
	HC	coated carbides
Ceramic cutting material	CA	Oxide ceramics based upon Al_2O_3
	CM	Mixed ceramics Al_2O_3 + metal carbide
	CN	Nitride ceramics based upon Si_3N_4 -Basis
	CC	coated ceramics
Boron nitride	BN	Polycrystalline cubic boron nitride (CBN)
Diamond	DP	Polycrystalline diamond (PCD)

DIN ISO 513 does not replace the manufacturers grade description or designation.
DIN ISO 513 gives a comparison for grades from various manufacturers.

Subject to technical changes developments.

No responsibility for errors or printer's errors accepted.

This catalog may not be reprinted or photocopied in whole or in part
without our written permission.

Edition March 2011



HORN - LEADERS IN GROOVING TECHNOLOGY



■ GROOVING

■ PARTING OFF

■ GROOVE MILLING

■ BROACHING

■ PROFILE MILLING

■ DRILLING

■ REAMING



HORN USA, Inc.

320 Premier Court
Suite 205
Franklin, TN 37067

Tel.: +1 (888)818-HORN
Fax: +1 (615)771-4101

E-Mail: sales@hornusa.com
www.hornusa.com



HARTMETALL-WERKZEUGFABRIK

PAUL HORN GmbH

Unter dem Holz 33-35
D-72072 Tübingen

Tel.: +49 (0)7071-7004 0
Fax: +49 (0)7071-7 28 93

E-Mail: info@phorn.de
www.phorn.de

HORN CUTTING TOOLS Ltd.

32 New Street
Ringwood
Hampshire
BH24 3AD

Tel.: +44 (0)1 425 481 800
Fax: +44 (0)1 425 481 888

E-Mail: info@phorn.co.uk
www.phorn.co.uk

HORN S.A.S

665, av. Blaise Pascal
Zone Industrielle
77127 Lieusaint

Tel.: +33 (0)1 64 88 5958
Fax: +33 (0)1 64 88 6049

E-Mail: infos@horn.fr
www.horn.fr

HORN Magyarország Kft.

H-9027 Győr
Gesztenyefa u. 4.

Tel.: +36 96 55 05 31
Fax: +36 96 55 05 32

E-Mail: technik@phorn.hu
www.phorn.hu